



## **BICYCLE-PEDESTRIAN ADVISORY COMMITTEE (BPAC)**

### **Regular Meeting**

Thursday, May 19, 2016  
3:00 pm

---

### **AGENDA**

- 1. Call to Order**
- 2. Roll Call**
- 3. Approval of Minutes**
  - *March 10, 2016 Regular Meeting*
- 4. Comments from the Public**
- 5. Approval of Agenda**
- 6. Action Items**
  - 6a. Draft FY 2016/17 – FY 2020/21 Transportation Improvement Program (TIP):** Review of the draft FY 2016/17 – FY 2020/21 TIP.  
  
***Action:** Review and recommend adoption of the draft TIP, recommend adoption with conditions, or do not recommend adoption.*
  - 6b. Transportation Alternatives Program (TAP) 2016 Grant Application:** Review and endorsement of a TAP grant application for the 2016 grant cycle.  
  
***Action:** Review and recommend endorsement of the TAP grant application for the 2016 grant cycle, recommend endorsement with conditions, or do not recommend endorsement.*
  - 6c. Walton Road Multimodal Improvements Feasibility Study:** Review of the draft Walton Road Multimodal Improvements Feasibility Study.  
  
***Action:** Review and recommend acceptance of the draft study, recommend acceptance with conditions, or do not recommend acceptance.*

## **7. Discussion Items**

**7a. Strategic Intermodal System (SIS) Multimodal Needs Plan Update:** A presentation by the Florida Department of Transportation District 4 (FDOT) on the update to the SIS Multimodal Needs Plan.

*Action: Discuss and provide comments to FDOT.*

**7b. Crossroads Mountain Biking Trail Update:** An update on the status of the Crossroads Mountain Biking Trail located in Fort Pierce that was discussed during the "Comments from the Public" agenda item at the March 10th BPAC meeting.

*Action: Discuss and identify next steps.*

## **8. Recommendations/Comments by Members**

## **9. Staff Comments**

**10. Next Meeting:** The next BPAC meeting is a regular meeting scheduled for 3:00 pm on Tuesday, July 14, 2016.

## **11. Adjourn**

## **NOTICES**

The St. Lucie TPO satisfies the requirements of various nondiscrimination laws and regulations including Title VI of the Civil Rights Act of 1964. Public participation is welcome without regard to race, color, national origin, age, sex, religion, disability, income, or family status. Persons wishing to express their concerns about nondiscrimination should contact Marceia Lathou, the Title VI/ADA Coordinator of the St. Lucie TPO, at 772-462-1593 or via email at lathoum@stlucieco.org.

Persons who require special accommodations under the Americans with Disabilities Act (ADA) or persons who require translation services (free of charge) should contact Marceia Lathou at 772-462-1593 at least five days prior to the meeting. Persons who are hearing or speech impaired may use the Florida Relay System by dialing 711.

Items not included on the agenda may also be heard in consideration of the best interests of **the public's health, safety, welfare, and as necessary to protect every person's right of access.** If any person decides to appeal any decision made by the St. Lucie TPO Advisory Committees with respect to any matter considered at a meeting, that person shall need a record of the proceedings, and for such a purpose, that person may need to ensure that a verbatim record of the proceedings is made which includes the testimony and evidence upon which the appeal is to be based.

Kreyol Ayisyen: Si ou ta renmen resevwa enfòmasyon sa a nan lang Kreyòl Ayisyen, tanpri rele nimewo 772-462-1593.

Español: Si usted desea recibir esta información en español, por favor llame al 772-462-1593.



Coco Vista Centre  
466 SW Port St. Lucie Blvd, Suite 111  
Port St. Lucie, FL 34953  
772-462-1593 www.stlucietpo.org

## BICYCLE-PEDESTRIAN ADVISORY COMMITTEE (BPAC)

### Regular Meeting

**DATE:** Thursday, March 10, 2016

**TIME:** 3:00 pm

**LOCATION:** St. Lucie TPO Boardroom  
Coco Vista Centre  
466 SW Port St. Lucie Boulevard, Suite 111  
Port St. Lucie, Florida

---

### MINUTES

#### 1. Call to Order

Chairman Brad Keen called the meeting to order at 3:06 pm.

#### 2. Roll Call

The roll was taken via sign-in sheet. A quorum was noted with the following members in attendance:

##### Members Present:

Brad Keen, Chair  
Jennifer McGee, Vice Chair  
Stewart Robertson  
Joseph DeFronzo  
Patrick McCallister  
Charles Barrowclough

##### Representing:

Port St. Lucie Parks and Recreation  
Department  
St. Lucie County Environmental  
Resources Department  
Kimley-Horn representing  
-FDOT District 4  
Resident - Bicycling  
Resident – Disabled  
St. Lucie County Environmental

##### Others Attending:

Peter Buchwald  
Marceia Lathou  
Ed DeFini

##### Representing:

St. Lucie TPO  
St. Lucie TPO  
St. Lucie TPO

Melissa Carter	Recording Specialist
Ronda Cerulli	Safe Kids Coalition
Paul Pierro	L.A.B
Karen Dalton	L.A.B
Travis Bailer	Airborne MTB Club

### 3. Comments from the Public

Travis Baylor of the Airborne Mountain Bike Club spoke regarding a Fort Pierce trail near the Turnpike. He said his Club has an agreement with the owner to use and maintain the trail. His concern is that this agreement could end. The trail's owner is willing to donate the easement and Mr. Baylor asked if the County would be willing to accept it.

Mr. Buchwald noted he is familiar with the trail which is in the jurisdiction of the City of Fort Pierce. He provided Mr. Baylor with the appropriate contact at the City.

Mr. McCallister initiated a discussion about the suitability of the trail for all users, including pedestrians and persons with disabilities. He stated he is willing to conduct a site review. Mr. McAllister also discussed the McCarty Ranch property which might offer another opportunity for an off-road trail.

Mr. Keen suggested this item could be placed on the agenda for the next BPAC meeting.

### 4. Approval of the Minutes

- January 14, 2016

\* **MOTION – MOVED** by Ms. McGee to approve the minutes of the January 14, 2016 regular Meeting.

\*\* **SECONDED** by Mr. McCallister Carried **UNANIMOUSLY**

### 5. Approval of Agenda

\* **MOTION – MOVED** by Ms. McGee to approve the agenda.

\*\* **SECONDED** by Mr. Barrowclough Carried **UNANIMOUSLY**



## 6. Action Items

**6a. Amendment to the FY 2015/16 – FY 2019/20 Transportation Improvement Program (TIP):** Review of an amendment to the FY 2015/16 – FY 2019/20 TIP for the McCarty Road Bridge Project.

Mr. Buchwald explained that the adopted TIP includes the replacement of the McCarty Road Bridge over Ten Mile Creek. Subsequent to the adoption of the TIP, it was determined by FDOT that a utilities phase needs to be added to the project because of the presence of utilities. FDOT is requesting that the TIP be amended to add this phase to the McCarty Road Bridge Project. Mr. Buchwald noted that the TIP amendment is consistent with the LRTP and does not impact the fiscal constraint of the TIP.

\* **MOTION – MOVED** by Mr. Barrowclough to recommend adoption of the TIP amendment for the McCarty Road Bridge Project.

\*\* **SECONDED** by Ms. McGee Carried **UNANIMOUSLY**

**6b. Draft FY 2016/17 – FY 2017/18 Unified Planning Work Program (UPWP):** Review of the draft FY 2016/17 – FY 2017/18 UPWP.

Mr. Buchwald explained the purpose of the UPWP. The current UPWP ends in June, therefore, it is necessary to adopt a new, two-year UPWP. He reviewed the proposed UPWP planning priorities which were presented at the November advisory committee meetings; these priorities basically continue the priorities of the current UPWP.

A Call for UPWP Projects was initiated at the November advisory committee meetings and was extended to the public through social media and extensive community outreach. The draft UPWP includes several projects which resulted from this Call for UPWP Projects. Mr. Buchwald highlighted the wide range of projects, activities, and programs the TPO will conduct over the next, two fiscal years.

Mr. Keen asked if the studies that were added based on the Call for UPWP Projects were funded. Mr. Buchwald replied they were funded and the funding sources are indicated in each UPWP task.

\* **MOTION – MOVED** by Mr. Barrowclough to recommend adoption of the draft UPWP.

**\*\*** **SECONDED** by Mr. McGee Carried **UNANIMOUSLY**

**6c. Title VI Program Update:** Review of a draft update to the TPO's Title VI Program.

Ms. Lathou provided background on Title VI and environmental justice (EJ). The proposed update to the TPO's Title VI Program is necessary to align with current laws, regulations, and data.

Ms. Lathou described the components of the Title VI Program update which include a public involvement process, Limited English Proficiency (LEP) Plan, complaint process, and public notice requirements. She described the EJ analysis that was conducted as part of the Go2040 LRTP.

The process for adoption of the Title VI program was described. It was noted that the update is currently being reviewed by FHWA Office of Civil Rights staff.

Ms. Lathou answered questions regarding the evaluation of the Title VI program and its applicability to other TPO programs such as SRTS. It was noted that although individuals had not dropped in for LEP assistance, the TPO through its EJ community outreach often encounters LEP individuals. The TPO hires bilingual assistants to provide language interpretation as needed for these events.

**\*** **MOTION – MOVED** by Mr. Barrowclough to review and recommend adoption of the draft update to the TPO's Title VI Program.

**\*\*** **SECONDED** by Mr. McCallister Carried **UNANIMOUSLY**

## **7. Recommendations/Comments by Members**

Mr. McCallister initiated a discussion of the recent Florida Community Bicycle Month Community Bike Ride. He presented a proclamation from the City of Port St. Lucie.

Mr. Barrowclough initiated a discussion of the Sun Trail program. He requested a letter of support from the BPAC for the submission of a local, regional trail in the statewide completion for funding. Mr. Buchwald noted that the St. Lucie Bike-Walk Network is included in the 2040 LRTP and other planning documents previously approved by

the BPAC so a letter of support would be a restatement of the BPAC's past support for trails.

- 8. **Staff Comments** - Mr. Buchwald highlighted some of the interesting items scheduled for the next TAC meeting including the TIP, Transportation Alternatives, the Waterways Feasibility Study and the Walton Road Multimodal Improvement Study.
  
- 9. **Next Meeting:** The next BPAC meeting is a regular meeting scheduled for 3:00 pm on Thursday, March 10, 2016.
  
- 10. **ADJOURN** - The meeting was adjourned at 4:50pm.

Respectfully Submitted:

Approved by:

---

Melissa Carter  
Recording Specialist

---

Brad Keen  
Chairman

## AGENDA ITEM SUMMARY

<b>Board/Committee:</b>	Bicycle-Pedestrian Advisory Committee (BPAC)
<b>Meeting Date:</b>	May 19, 2016
<b>Item Number:</b>	6a
<b>Item Title:</b>	Draft FY 2016/17 – FY 2020/21 Transportation Improvement Program (TIP)
<b>Item Origination:</b>	Federal and State requirements
<b>UPWP Reference:</b>	Task 3.3– TIP
<b>Requested Action:</b>	Review and recommend adoption of the Draft TIP, recommend adoption with conditions, or do not recommend adoption
<b>Staff Recommendation:</b>	As the Final Tentative Work Program appears to be consistent with the Draft Tentative Work Program that was recommended for endorsement by the TPO advisory committees, it is recommended that the draft FY 2016/17 – FY 2020/21 TIP be recommended for adoption by the TPO Board.

### **Attachments**

- Staff Report
- Draft FY 2016/17 – FY 2020/21 TIP



Coco Vista Centre  
466 SW Port St. Lucie Blvd, Suite 111  
Port St. Lucie, FL 34953  
772-462-1593 www.stlucietpo.org

## **MEMORANDUM**

**TO:** Bicycle-Pedestrian Advisory Committee (BPAC)

**FROM:** Peter Buchwald  
Executive Director

**DATE:** May 12, 2016

**SUBJECT: Draft FY 2016/17 – FY 2020/21 Transportation Improvement Program (TIP)**

---

### **BACKGROUND**

According to Federal and State requirements, the St. Lucie Transportation Planning Organization (TPO) annually must develop a Transportation Improvement Program (TIP). The purpose of the TIP is to identify the transportation improvement projects located within the TPO area that have been prioritized and are receiving Federal and State funding over a five-year period.

In addition, the TIP is used to coordinate projects among the U.S. Department of Transportation (USDOT), the Florida Department of Transportation (FDOT), and the local governments located within the TPO area. The TIP is developed and adopted annually by the TPO in cooperation with the USDOT, FDOT, TPO advisory committees, local governments, port and aviation authorities, transit operators, and the general public.

### **ANALYSIS**

The development of the TIP is a year-long process that is continuous, cooperative, and comprehensive. For the TPO's FY 2016/17 – FY 2020/21 TIP, the process started in June 2015 with a meeting with staffs from the St. Lucie TPO, FDOT District 4, and the local governments to informally discuss the TPO's priority projects. The List of Priority Projects (LOPP) then was developed, reviewed by the TPO advisory committees, adopted by the TPO Board, and submitted to FDOT District 4 in August 2015.

The LOPP was utilized by FDOT District 4 to develop their Draft Tentative Work Program for FY 2016/17 – FY 2020/21. The Draft Tentative Work Program was reviewed and recommended for endorsement by the TPO advisory committees in July 2015 and was endorsed by the TPO Board in October 2015.

In the Draft Tentative Work Program, the phases that were advanced include a reserve for the construction of Port St. Lucie Boulevard from Paar Drive to Darwin Boulevard, a reserve for right-of-way (ROW) acquisition for Midway Road from Glades Cut Off to Selvitz Road, the construction of the intersection improvement at U.S. Highway 1 and Virginia, the construction of the St. Lucie Advanced Transportation Management System, the design of Port St. Lucie Boulevard from Becker Road to Paar Drive, and the design of Kings Highway from the I-95 Overpass to St. Lucie Boulevard. In addition, other highlights of the DTWP include the programming of the construction of the Parr Drive Sidewalk from Port St. Lucie Boulevard to Darwin Boulevard, the acquisition of ROW for the I-95 Jobs Express Terminal and Park and Ride Lot on Gatlin Boulevard, and the installation of adaptive signal control technology on U.S. Highway 1 between Virginia Avenue and Avenue H.

The Final Tentative Work Program was received from FDOT in April 2016 and was used to prepare the attached TIP through the web-based Interactive TIP. The Final Tentative Work Program is a primary component of the TIP.

The Final Tentative Work Program was reviewed by TPO staff for consistency with the Draft Tentative Work Program. The Final Tentative Work Program appears to be consistent with the Draft Tentative Work Program.

## **RECOMMENDATION**

As the Final Tentative Work Program appears to be consistent with the Draft Tentative Work Program that was recommended for endorsement by the TPO advisory committees, it is recommended that the draft FY 2016/17 – FY 2020/21 TIP be recommended for adoption by the TPO Board.



**DRAFT**  
**TRANSPORTATION IMPROVEMENT PROGRAM**  
**FY 2016/17 - FY 2020/21**

Adopted by the St. Lucie Transportation Planning Organization

on \_\_\_\_\_

\_\_\_\_\_  
Chairwoman Kathryn Hensley

**TIP CONTACT INFORMATION**

466 SW Port St. Lucie Boulevard  
Port St. Lucie, FL 34953

Yi Ding, Program Manager  
[www.stlucietpo.org](http://www.stlucietpo.org)

phone: (772) 462-1593  
fax: (772) 462-2549

ENDORSEMENT: The Transportation Improvement Program of the St. Lucie Transportation Planning Organization has been developed consistent with Federal regulations 23 U.S.C. 134(j) and 23 CFR 450 and Florida Statute 339.175(8) in cooperation with the Florida Department of Transportation and public transit operators.

ACKNOWLEDGMENT: The preparation of this report has been funded in part through grants from the Federal Highway Administration and Federal Transit Administration, U.S. Department of Transportation (USDOT), under the Metropolitan Planning Program of the U.S. Code (Title 23, Section 104f). The contents of this report do not necessarily reflect the official views or policy of the USDOT.

## TABLE OF CONTENTS

<b>SECTION</b>		<b>PAGE</b>
<b>A.</b>	<b>INTRODUCTION</b>	<b>A - 1</b>
A. 1	How to Use the TIP	A - 1
A. 2	Project Index and TIP/LRTP Cross Reference	A - 2
A. 3	Project Location Maps	A - 3
A. 4	Glossary of Abbreviations and Phase/Funding Source Codes	A - 5
A. 5	TPO Metropolitan Planning Area Map	A - 7
<b>B.</b>	<b>NARRATIVE</b>	<b>B - 1</b>
B. 1	Purpose	B - 1
B. 2	Financial Plan	B - 1
B. 3	Project Selection	B - 5
B. 4	Consistency with Other Plans	B - 5
B. 5	Project Priority Statement	B - 5
B. 6	Public Involvement	B - 6
B. 7	TIP Amendments	B - 6
B. 8	Annual Listing of Obligated Federal Funding/Implemented Projects	B - 6
B. 9	Certifications	B - 10
B. 10	Congestion Management Process (CMP)	B - 10
B. 11	St. Lucie Transportation Disadvantaged (TD) Program	B - 11
B. 12	Transportation Regional Incentive Program (TRIP)	B - 12
<b>C.</b>	<b>DETAILED PROJECT LISTINGS</b>	<b>C - 1</b>
C. 1	Highway/Roadway/Sidewalk Projects	C 1 - 1
C. 2	Aviation Projects	C 2 - 1
C. 3	Transit Projects	C 3 - 1
C. 4	Miscellaneous Projects	C 4 - 1
C. 5	Planning	C 5 - 1
C. 6	Bridge Projects	C 6 - 1
C. 7	Turnpike Enterprise Projects	C 7 - 1
C. 8	Seaport Projects	C 8 - 1
<b>D.</b>	<b>LIST OF PRIORITY PROJECTS</b>	<b>D - 1</b>
<b>E.</b>	<b>PERFORMANCE MANAGEMENT</b>	<b>E - 1</b>

### **APPENDICES**

- Appendix A: Example Public Comment Notice
- Appendix B: Local Projects-City of Fort Pierce
- Appendix C: Local Projects-City of Port St. Lucie
- Appendix D: Local Projects-St. Lucie County
- Appendix E: TIP Amendment Forms



## A. INTRODUCTION

### A.1 How to Use the TIP

The intent of the Transportation Improvement Program (TIP) is to identify and prioritize the transportation improvement projects over the next five years that are receiving State and Federal funding and are located within the Metropolitan Planning Area (MPA) of the St. Lucie Transportation Planning Organization (St. Lucie TPO). The St. Lucie TPO MPA is identified on the map on page A-7.

To use the TIP:

- Locate the project in the Project Index in Section A.2 or on either of the Project Location Maps in Section A.3 to identify the Project Number or Project Name.
- Using the Project Name, reference directly the alphabetically-listed projects in the Detailed Project Listing pages or, by using the Project Number, identify the TIP Page Number for the project from the Project Index.
- Refer to the corresponding TIP Page Number to obtain information regarding the project in the Detailed Project Listings pages.
- Refer to the corresponding LRTP Page Number in the Project Index or in the Detailed Project Listings pages to cross-reference the project, if applicable, in the Go2040 Long Range Transportation Plan (LRTP).
- Refer to Section A.4 for a Glossary of Abbreviations and Phase/Funding Codes.
- Refer to Section B for information on Federal and State requirements for development of the TIP.
- Refer to Section C for the Detailed Project Listings which include whether the project is located on the Florida Strategic Intermodal System (SIS) and the Total Project Cost.
- Refer to Section D for the TPO List of Priority Projects.
- Refer to Section E for an evaluation of project and system performance
- Refer to the Appendices for an Example Public Comment Notice and for information on locally-funded projects and TIP amendments that have been adopted.
- Refer to the contact information on the cover of the TIP if you have any questions or comments.

### **Explanations of the SIS and Total Project Costs**

**SIS:** The SIS is a network of high priority transportation facilities in Florida which includes the State's largest and most significant commercial service airports, spaceport, deep-water seaports, freight and passenger rail terminals, intercity bus terminals, rail corridors, waterways and highways. All projects on the SIS will have a SIS identifier in the top right corner of the Detailed Project Listings pages in Section C of the TIP.

**Total Project Costs:** A typical project production sequence is to have a Project Development and Environment (PD&E) phase, followed by a Design (PE) phase, a Right of Way (ROW) phase and a Construction (CST) phase. Some projects may not include a ROW phase if land acquisition is not needed to complete the project. Costs in the Detailed Project Listing pages in Section C of the TIP may include the historical costs (Prior Year Cost), the costs in the five years of the current TIP, the costs in the years beyond the current TIP (Future Year Cost), and the sum of all of these costs which is the Total Project Cost. For some projects such as resurfacing, safety, or operational projects, there may not be a Total Project Cost identified, but additional details on that program will be included.

**A.2 Project Index and TIP/LRTP Cross Reference**

PROJECT NAME	PROJECT LIMITS FROM	PROJECT LIMITS TO	PROJECT TYPE	PROJECT NUMBER	TIP PAGE	TIP MAP PAGE	LRTP PAGE
KING'S HIGHWAY / SR-713	800' S OF SR-70	NORTH OF PICOS ROAD	ADD LANES & RECONSTRUCT	2302566	C 1-6	A - 3	6-2
KING'S HIGHWAY / SR-713	NORTH OPF PICOS ROAD	NORTH OF I-95 OVERPASS	ADD LANES & RECONSTRUCT	2302567	C 1-7	A - 3	6-2
KING'S HIGHWAY / SR-713	800' S OF SR-70	N OF PICOS RD	LANDSCAPING	2302568	C 1-8	A - 3	6-2
INDRIO ROAD / SR-614	WEST OF SR-9/I-95	EAST OF SR-670/EMERSON AVE	ADD LANES & RECONSTRUCT	2303384	C 1-5	A - 3	6-2
MIDWAY ROAD / CR-712	S. 25TH ST/SR-615	SR-5/US-1	ADD LANES & RECONSTRUCT	2314402	C 1-12	A - 3	6-2
MIDWAY ROAD / CR-712	GLADES CUT OFF ROAD	SELVITZ ROAD	PD&E/EMO STUDY	2314403	C 1-13	A - 3	6-5
CROSTOWN PARKWAY	MANTH LANE	SR-5/US-1	RIGHT OF WAY ACTIVITIES	4108444	C 1-2	A - 4	7-1
PARK AND RIDE LOT	HOMEDEPOT ON GATLIN BLVD	HOMEDEPOT ON GATLIN BLVD	PARK AND RIDE LOTS	4226814	C 3-8	A - 4	7-1
KING'S HIGHWAY / SR-713	Intersection	Intersection	ADD TURN LANE(S)	4241431	C 1-9	A - 3	6-2
KING'S HIGHWAY / SR-713	INTERSECTION	INTERSECTION	ADD TURN LANE(S)	4241432	C 1-10	A - 3	6-2
BRIDGE 940094 SEAWAY DRIVE	East end of Bridge	West End of Bridge	BRIDGE-REPAIR/REHABILITATION	4268401	C 6-4	A - 3	6-2
US HIGHWAY 1	MIDWAY ROAD	EDWARDS ROAD	SIDEWALK	4287281	C 1-27	A - 3	6-2
OKEECHOBEE ROAD / SR-70	900' W OF JENKINS RD	2700' E OF JENKINS RD	ADD LANES & REHABILITATE PVMNT	4289841	C 1-14	A - 3	7-1
BRIDGE 940045 N. CAUSEWAY	US 1	2,000' East of East Bridge Terminus	BRIDGE-REPAIR/REHABILITATION	4299362	C 6-3	A - 3	6-2
FEC/AMTRAK PASSENGER SERVICE	Indian River County	Martin County	RAIL CAPACITY PROJECT	4301261	C 4-2	A - 3	7-1
PORT ST. LUCIE BOULEVARD	FROM PAAR DRIVE	DARWIN BLVD	ADD LANES & RECONSTRUCT	4317522	C 1-16	A - 4	6-5
PORT ST. LUCIE BOULEVARD	BECKER ROAD	PAAR DRIVE	ADD LANES & RECONSTRUCT	4317523	C 1-17	A - 4	7-1
25 STREET / SR-615	ST LUCIE BOULEVARD	US 1	RESURFACE, ADD SIDEWALKS	4323261	C 1-28	A - 3	6-2
McCARTY ROAD BRIDGE 940031	ENTIRE BRIDGE	ENTIRE BRIDGE	BRIDGE REPLACEMENT	4343601	C 6-2	A - 3	6-2
PORT ST. LUCIE BOULEVARD	Intersection	Intersection	INTERSECTION IMPROVEMENT	4351351	C 1-18	A - 4	6-2
ST. LUCIE COUNTY ATMS	SAVANA CLUB BLVD, KINGS HWY	KINGS HWY, US-1	ATMS - ARTERIAL TRAFFIC MGMT	4352451	C 1-25	A - 3	6-2
SELVITZ ROAD	Bayshore Blvd.	North Macedo Blvd.	SIDEWALK	4352631	C 1-20	A - 4	6-2
I-95 AT ST. LUCIE WEST BLVD	INTERCHANGE	INTERCHANGE	ADD LANES & RECONSTRUCT	4353371	C 1-24	A - 4	6-2
MIDWAY ROAD BRIDGE 940050	ENTIRE BRIDGE	ENTIRE BRIDGE	PAINT BRIDGE	4354101	C 7-2	A - 4	7-1
I-95 BRIDGE DECK REPLACEMENT	CR-709 & FEC R/R	TEN MILE CREEK	BRIDGE REHABILITATION	4366171	C 1-4	A - 3	6-2
I-95 BRIDGE DECK REPLACEMENT	GATLIN BLVD	MIDWAY RD	BRIDGE REHABILITATION	4366461	C 1-3	A - 3	6-2
TULIP BOULEVARD	COLLEGE PARK ROAD	CHERRY HILL ROAD	SIDEWALK	4368591	C 1-26	A - 4	6-2
US-1 @ VIRGINIA AVENUE	Intersection	Intersection	ADD RIGHT TURN LANE(S)	4368681	C 1-22	A - 3	6-2
KINGS HWY / SR-713	NORTH OF PICOS RD	NORTH OF SR-9/I-95 OVERPASS	LANDSCAPING	4380411	C 4-3	A - 3	7-1
PAAR DRIVE	SW PORT ST.LUCIE BLVD	SW DARWIN BLVD	SIDEWALK	4381301	C 1-15	A - 4	7-1
KINGS HWY / SR-713	SR-9/I-95 OVERPASS	ST. LUCIE BOULEVARD	ADD LANES & RECONSTRUCT	4383791	C 1-23	A - 3	6-5
MIDWAY RD / CR-712	GLADES CUT OFF ROAD	SELVITZ ROAD	FUNDING ACTION	4385431	C 1-11	A - 4	6-5
PORT ST. LUCIE BOULEVARD	PAAR DRIVE	DARWIN BLVD	FUNDING ACTION	4385441	C 1-19	A - 4	7-1
SR-5/US-1	VIRGINIA AVENUE	AVENUE H	ATMS - ARTERIAL TRAFFIC MGMT	4385461	C 1-21	A - 3	7-1
PORT OF FT. PIERCE FISHERMAN'S WHARF	PORT OF FT. PIERCE	PORT OF FT. PIERCE	SEAPORT CAPACITY PROJECT	4387911	C 8-2	A - 3	7-1

Note: An \* In the LRTP Page column indicates that the project was included in the Go2040 Long Range Transportation Plan (LRTP) Cost Feasible Plan and is now funded for construction and outside of the Go2040 LRTP planning period.

The projects included in this table are illustrated on maps in Section A.3

**A.3 TIP Project Location Maps**

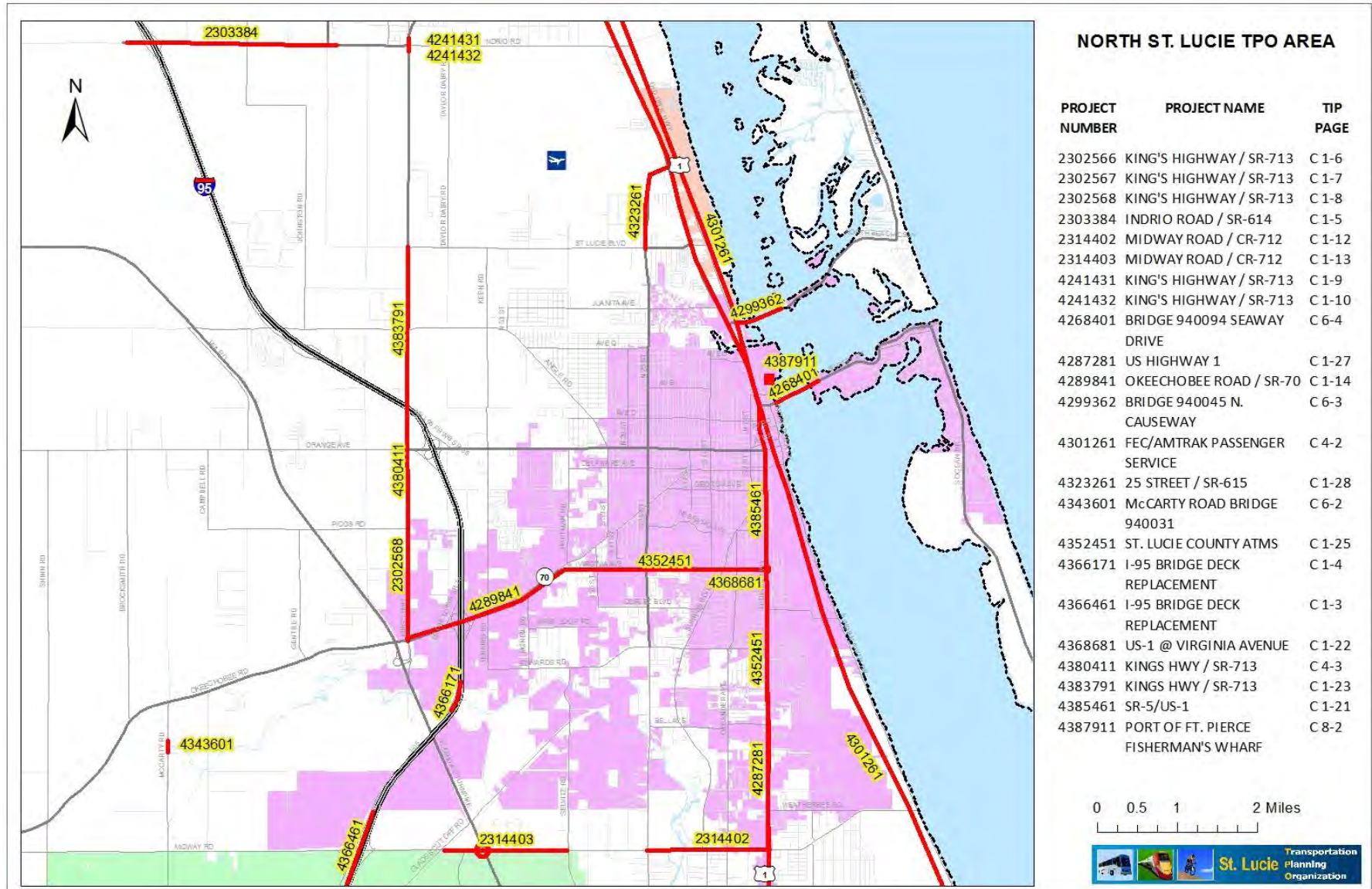



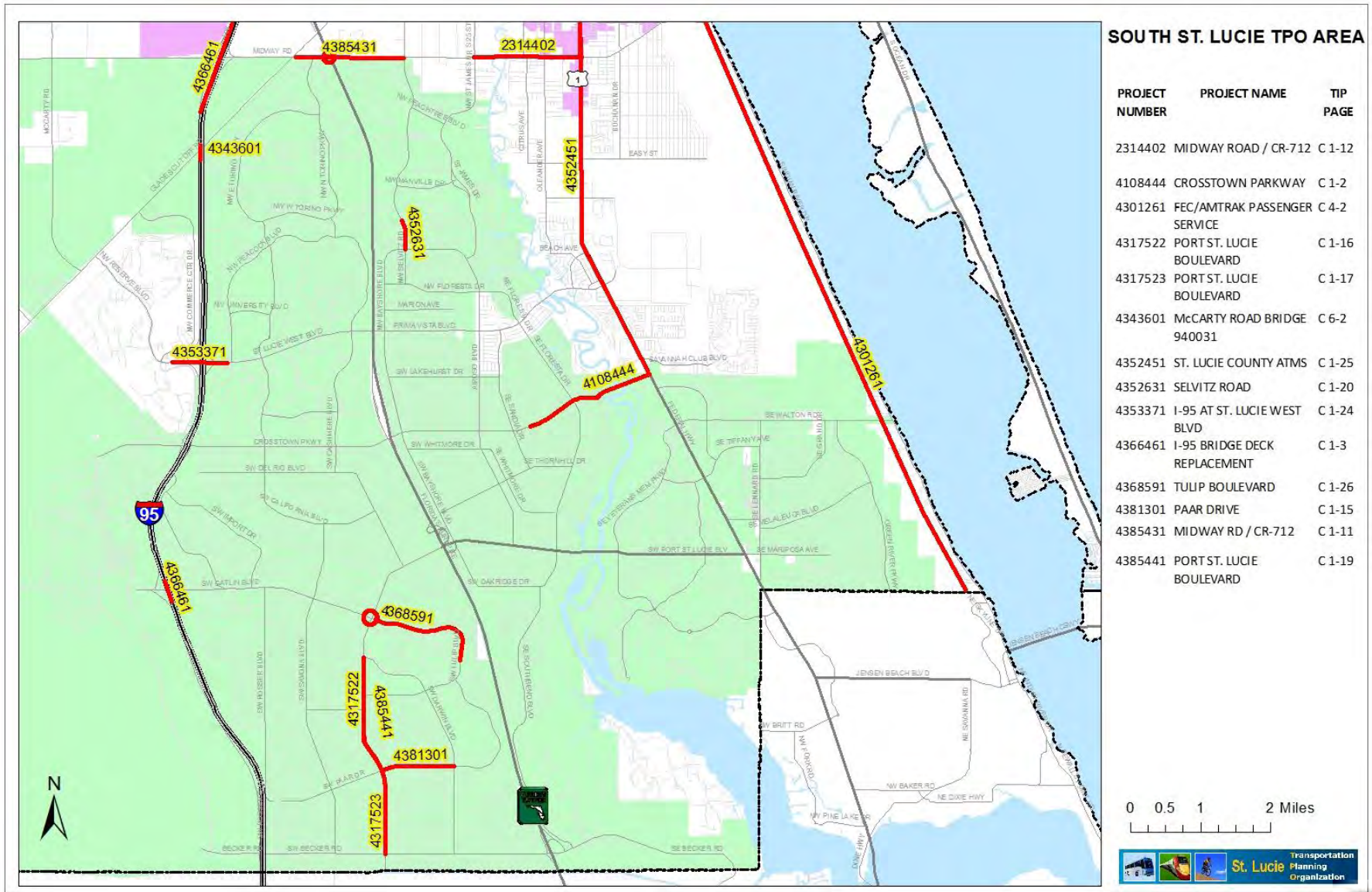

**A.4 Glossary of Abbreviations and Phase/Funding Source Codes**

ADM	Administration
BPAC	Bicycle Pedestrian Advisory Committee
BRDG	Bridge
CAC	Citizens Advisory Committee
CEI	Construction, Engineering, & Inspection
CIP	Capital Improvements Program
CLV	Culvert
CMP	Congestion Management Process
CST	Construction
CTC	Community Transportation Coordinator
DCA	Department of Community Affairs
E/D	Engineering & Design
ENV	Environmental
EPA	Environmental Protection Agency
FAA	Federal Aviation Administration
FDOT	Florida Department of Transportation
FHWA	Federal Highway Administration
FTA	Federal Transit Administration
INC	Construction Incentive
IRC	Indian River County
LAR	Local Agency Reimbursement
LCB	Local Coordinating Board
LOPP	List of Priority Projects
MAP - 21	Moving Ahead for Progress in the 21st Century
MC	Martin County
MIT	Mitigation
MPO	Metropolitan Planning Organization
MSC	Grant to Local Government

PD&E	Project Development and Environmental
PE	Preliminary Engineering
PIP	Public Involvement Program
PLN	Planning
PST DES	Post Design
PTO	Public Transportation Office
RELOC	Right of Way Relocation
RLRTP	Regional Long Range Transportation Plan
ROW	Right of Way Support
ROW LND	Right of Way Land
RR CST	Railroad Construction
RRX	Railroad Crossing
RRU	Railroad/Utilities Construction
SAFETEA-LU	Safe, Accountable, Flexible, Efficient Transportation Equity Act—a Legacy for Users
SLC	St. Lucie County
SRA	Senior Resource Association, Inc.
TAC	Technical Advisory Committee
TD	Transportation Disadvantaged
TDC	Transportation Disadvantaged Commission
TIP	Transportation Improvement Program
TMA	Transportation Management Area
TPO	Transportation Planning Organization
UPWP	Unified Planning Work Program
UTL	Utility Coordination

Fund Source Codes

Fund Source	Fund Code	Fund Code Description
Federal	ACNP	ADVANCE CONSTRUCTION NHPP
Federal	ACSB	ADVANCE CONSTRUCTION (SABR)
Federal	ACTU	ADVANCE CONSTRUCTION (TALU)
Federal	CM	CONGESTION MITIGATION -AQ
Federal	DU	STATE PRIMARY/FEDERAL REIMB
Federal	FAA	FEDERAL AVIATION ADMIN
Federal	FTA	FEDERAL TRANSIT ADMINISTRATION
Federal	PL	METRO PLAN (85% FA; 15% OTHER)
Federal	NHRE	NAT HWY PERFORMANCE PROGRAM - RESURFACING
Federal	SA	STP, ANY AREA
Federal	SU	STP, URBAN AREAS > 200K
Federal	TALT	TRANSPORTATION ALTS-ANY AREA
Federal	TALU	TRANSPORTATION ALTS- >200K

Fund Source	Fund Code	Fund Code Description
State 100%	BRRP	STATE BRIDGE REPAIR & REHAB
State 100%	CIGP	COUNTY INCENTIVE GRANT PROGRAM
State 100%	D	UNRESTRICTED STATE PRIMARY
State 100%	DDR	DISTRICT DEDICATED REVENUE
State 100%	DIH	STATE IN-HOUSE PRODUCT SUPPORT
State 100%	DITS	STATEWIDE ITS
State 100%	DPTO	STATE -PTO
State 100%	DS	STATE PRIMARY HIGHWAYS & PTO
State 100%	TRIP	TRANS REGIONAL INCENTIVE PROGM
Local	LF	LOCAL FUNDS
Local	LFP	LOCAL FUNDS FOR PARTICIPATING
Toll/Turnpike	PKYR	TURNPIKE RENEWAL & REPLACEMENT

# A.5 TPO Metropolitan Planning Area Map

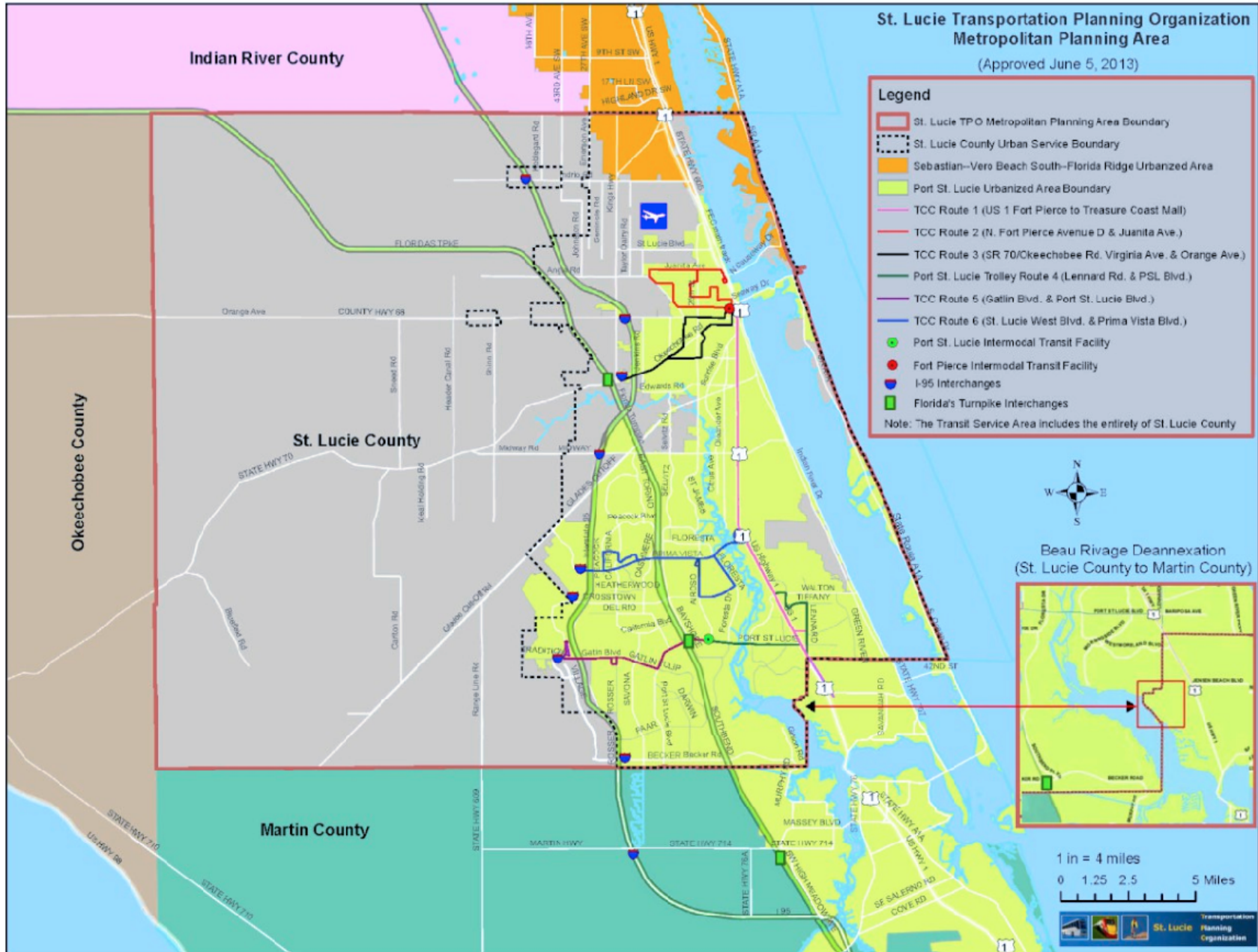

## **B. NARRATIVE**

### **B.1 Purpose**

The purpose of the TIP is to identify and prioritize transportation improvement projects receiving Federal and State funding over a five-year period that are located within the St. Lucie TPO MPA. In addition, the TIP is used to coordinate the transportation improvement projects of the U.S. Department of Transportation (USDOT), the Florida Department of Transportation (FDOT), and the local governments located within the MPA. Projects in the TIP are presented in Year of Expenditure (YOE), which takes into account the inflation rate over the five years in the TIP. Therefore the programmed cost estimate for each project is inflated to the year that the funds are expended based on reasonable inflation factors developed by the State and its partners. The TIP is also used to identify all regionally significant transportation projects for which Federal action is required, whether or not the projects receive Federal funding. As the St. Lucie TPO is in an air quality attainment area, there are no regionally significant air quality-related transportation improvement projects in the TIP.

### **B.2 Financial Plan**

The Financial Plan of the TIP is based upon the FDOT District 4 Tentative Work Program for FY 2016/17 – FY 2020/21; the previous **year's TIP**; the Go2040 Long Range Transportation Plan (LRTP); and information provided by St. Lucie County, the City of Port St. Lucie, and the City of Fort Pierce. The Financial Plan includes Federal, State, and local transportation funding sources which are identified in the following tables based on the type of transportation improvement:



<b>HIGHWAY/ROADWAY/SIDEWALKS</b>	<b>FUND</b>	<b>TOTAL</b>	<b>2016/17</b>	<b>2017/18</b>	<b>2018/19</b>	<b>2019/20</b>	<b>2020/21</b>
<b>FUNDING SOURCE</b>		<b>PROGRAM</b>					
ACBR - ADVANCE CONSTRUCTION (BRT)	ACBR	3,194,330	761,000	398,723	1,000,000	1,034,607	0
BRRP - STATE BRIDGE REPAIR & REHAB	BRRP	23,789,931	23,189,931	300,000	300,000	0	0
CIGP - COUNTY INCENTIVE GRANT PROGRAM	CIGP	5,790,832	2,953,261	1,242,823	1,343,720	251,028	0
DDR - DISTRICT DEDICATED REVENUE	DDR	35,915,945	4,060,952	21,810,854	4,885,594	0	5,158,545
DIH - STATE IN-HOUSE PRODUCT SUPPORT	DIH	1,215,366	573,178	316,816	237,951	0	87,421
DITS - STATEWIDE ITS - STATE 100%	DITS	1,316,535	1,316,535	0	0	0	0
DS - STATE PRIMARY HIGHWAYS & PTO	DS	59,537,076	5,061,859	25,254,942	17,404,164	6,266,111	5,550,000
LF - LOCAL FUNDS	LF	3,308,216	0	196,394	3,111,822	0	0
LFP - LOCAL FUNDS FOR PARTICIPATING	LFP	7,762,439	4,794,028	1,242,823	1,474,560	251,028	0
NHRE - NAT HWY PERFORM - RESURFACING	NHRE	2,490,930	0	2,490,930	0	0	0
SA - STP, ANY AREA	SA	6,195,385	322,015	1,225,702	1,168,203	2,408,335	1,071,130
SU - STP, URBAN AREAS > 200K	SU	15,262,351	5,239,424	4,688,271	1,591,935	1,732,721	2,010,000
TALT - TRANSPORTATION ALTS- ANY AREA	TALT	244,939	0	165,263	79,676	0	0
TALU - TRANSPORTATION ALTS- >200K	TALU	1,123,582	343,705	475,369	304,508	0	0
TRIP - TRANS REGIONAL INCENTIVE PROGM	TRIP	417,174	0	0	417,174	0	0
TRWR - 2015 SB2514A-TRAN REG INCT PRG	TRWR	3,185,041	369,031	0	2,816,010	0	0
<b>GRAND TOTAL</b>		<b>170,750,072</b>	<b>48,984,919</b>	<b>59,808,910</b>	<b>36,135,317</b>	<b>11,943,830</b>	<b>13,877,096</b>

<b>AVIATION FUNDING SOURCES</b>	<b>FUND</b>	<b>TOTAL</b>	<b>2016/17</b>	<b>2017/18</b>	<b>2018/19</b>	<b>2019/20</b>	<b>2020/21</b>
		<b>PROGRAM</b>					
DDR - DISTRICT DEDICATED REVENUE	DDR	1,197,437	918,899	0	278,538	0	0
DPTO - STATE - PTO	DPTO	1,597,249	988,301	97,500	327,462	183,986	0
FAA - FEDERAL AVIATION ADMIN	FAA	5,606,754	0	675,000	1,620,000	3,311,754	0
LF - LOCAL FUNDS	LF	962,286	506,800	52,500	219,000	183,986	0
<b>GRAND TOTAL</b>		<b>9,363,726</b>	<b>2,414,000</b>	<b>825,000</b>	<b>2,445,000</b>	<b>3,679,726</b>	<b>0</b>

<b>BRIDGE FUNDING SOURCES</b>	<b>FUND</b>	<b>TOTAL</b>	<b>2016/17</b>	<b>2017/18</b>	<b>2018/19</b>	<b>2019/20</b>	<b>2020/21</b>
		<b>PROGRAM</b>					
ACBR - ADVANCE CONSTRUCTION (BRT)	ACBR	49,672,592	2,790,387	1,344,305	44,617,552	19,000	901,348
BRP - STATE BRIDGE REPLACEMENT	BPR	2,925,000	0	2,000,000	0	925,000	0
BRRP - STATE BRIDGE REPAIR & REHAB	BRRP	5,833,146	5,833,146	0	0	0	0
DDR - DISTRICT DEDICATED REVENUE	DDR	1,056,676	0	0	1,056,676	0	0
DIH - STATE IN-HOUSE PRODUCT SUPPORT	DIH	315,575	148,133	0	167,442	0	0
DS - STATE PRIMARY HIGHWAYS & PTO	DS	17,381,332	0	0	17,381,332	0	0
SA - STP, ANY AREA	SA	667,311	329,071	150,000	188,240	0	0
<b>GRAND TOTAL</b>		<b>77,851,632</b>	<b>9,100,737</b>	<b>3,494,305</b>	<b>63,411,242</b>	<b>944,000</b>	<b>901,348</b>

Note: See Section A-7 for Fund Code Source and Fund Code Description

<b>TRANSIT OPERATIONS, EQUIPMENT &amp; FACILITIES</b>	<b>FUND</b>	<b>TOTAL</b>	<b>2016/17</b>	<b>2017/18</b>	<b>2018/19</b>	<b>2019/20</b>	<b>2020/21</b>
<b>FUNDING SOURCES</b>		<b>PROGRAM</b>					
DDR - DISTRICT DEDICATED REVENUE	DDR	6,205,517	342,168	353,911	935,956	510,981	4,062,501
DIH - STATE IN-HOUSE PRODUCT SUPPORT	DIH	181,055	0	0	0	40,000	141,055
DITS - STATEWIDE ITS - STATE 100%	DITS	1,256,073	238,964	244,938	251,062	257,338	263,771
DPTO - STATE - PTO	DPTO	2,305,441	538,071	551,981	0	598,714	616,675
DS - STATE PRIMARY HIGHWAYS & PTO	DS	4,089,956	0	0	0	4,089,956	0
DU - STATE PRIMARY/FEDERAL REIMB	DU	286,992	50,980	60,547	63,465	56,000	56,000
FTA - FEDERAL TRANSIT ADMINISTRATION	FTA	14,457,000	2,891,400	2,891,400	2,891,400	2,891,400	2,891,400
LF - LOCAL FUNDS	LF	3,166,770	593,184	612,528	633,669	654,714	672,675
<b>GRAND TOTAL</b>		<b>31,948,804</b>	<b>4,654,767</b>	<b>4,715,305</b>	<b>4,775,552</b>	<b>9,099,103</b>	<b>8,704,077</b>
<b>PLANNING FUNDING SOURCE</b>	<b>FUND</b>	<b>TOTAL</b>	<b>2016/17</b>	<b>2017/18</b>	<b>2018/19</b>	<b>2019/20</b>	<b>2020/21</b>
		<b>PROGRAM</b>					
DPTO - STATE - PTO	DPTO	46,297	11,710	11,529	11,529	11,529	0
DU - STATE PRIMARY/FEDERAL REIMB	DU	411,067	93,679	92,229	61,465	71,465	92,229
LF - LOCAL FUNDS	LF	46,297	11,710	11,529	11,529	11,529	0
PL - METRO PLAN (85% FA; 15% OTHER)	PL	2,005,156	0	501,289	501,289	501,289	501,289
<b>GRAND TOTAL</b>		<b>2,508,817</b>	<b>117,099</b>	<b>616,576</b>	<b>585,812</b>	<b>595,812</b>	<b>593,518</b>
<b>MISCELLANEOUS FUNDING SOURCES</b>	<b>FUND</b>	<b>TOTAL</b>	<b>2016/17</b>	<b>2017/18</b>	<b>2018/19</b>	<b>2019/20</b>	<b>2020/21</b>
		<b>PROGRAM</b>					
D - UNRESTRICTED STATE PRIMARY	D	10,565,000	2,819,000	2,582,000	2,582,000	2,582,000	0
DDR - DISTRICT DEDICATED REVENUE	DDR	15,000	0	0	0	0	15,000
DIH - STATE IN-HOUSE PRODUCT SUPPORT	DIH	5,000	0	0	0	0	5,000
GMR - GROWTH MANAGEMENT FOR SIS	GMR	25,000,000	25,000,000	0	0	0	0
<b>GRAND TOTAL</b>		<b>35,585,000</b>	<b>27,819,000</b>	<b>2,582,000</b>	<b>2,582,000</b>	<b>2,582,000</b>	<b>20,000</b>
<b>TURNPIKE ENTERPRISE FUNDING SOURCE</b>	<b>FUND</b>	<b>TOTAL</b>	<b>2016/17</b>	<b>2017/18</b>	<b>2018/19</b>	<b>2019/20</b>	<b>2020/21</b>
		<b>PROGRAM</b>					
PKYR - TOLL / TURNPIKE	PKYR	373,271	44,920	328,351	0	0	0
<b>GRAND TOTAL</b>		<b>373,271</b>	<b>44,920</b>	<b>328,351</b>	<b>0</b>	<b>0</b>	<b>0</b>
<b>SEAPORT FUNDING SOURCES</b>	<b>FUND</b>	<b>TOTAL</b>	<b>2016/17</b>	<b>2017/18</b>	<b>2018/19</b>	<b>2019/20</b>	<b>2020/21</b>
		<b>PROGRAM</b>					
DDR - DISTRICT DEDICATED REVENUE	DDR	255,000	255,000	0	0	0	0
PORT - SEAPORTS	PORT	255,000	255,000	0	0	0	0
<b>GRAND TOTAL</b>		<b>510,000</b>	<b>510,000</b>	<b>0</b>	<b>0</b>	<b>0</b>	<b>0</b>

The TIP is financially constrained each year with the project cost estimates equal to the funding source estimates as demonstrated in the Financial Summary below:

<b>PROJECT FUNDING SOURCE ESTIMATES</b>	<b>PROGRAM GRAND TOTAL</b>	<b>2016/17 TOTAL</b>	<b>2017/18 TOTAL</b>	<b>2018/19 TOTAL</b>	<b>2019/20 TOTAL</b>	<b>2019/21 TOTAL</b>
HIGHWAY / ROADWAY / SIDEWALK	170,750,072	48,984,919	59,808,910	36,135,317	11,943,830	13,877,096
AVIATION	9,363,726	2,414,000	825,000	2,445,000	3,679,726	0
TRANSIT OPERATIONS EQUIPMENT & FACILITIES	31,948,804	4,654,767	4,715,305	4,775,552	9,099,103	8,704,077
MISCELLANEOUS	35,585,000	27,819,000	2,582,000	2,582,000	2,582,000	20,000
PLANNING	2,508,817	117,099	616,576	585,812	595,812	593,518
BRIDGE	77,851,632	9,100,737	3,494,305	63,411,242	944,000	901,348
TURNPIKE ENTERPRISE	373,271	44,920	328,351	0	0	0
SEAPORT	510,000	510,000	0	0	0	0
<b>GRAND TOTAL FROM ALL FUNDING SOURCES</b>	<b>328,891,322</b>	<b>93,645,442</b>	<b>72,370,447</b>	<b>109,934,923</b>	<b>28,844,471</b>	<b>24,096,039</b>
<b>PROJECT COST ESTIMATES</b>	<b>PROGRAM GRAND TOTAL</b>	<b>2016/17 TOTAL</b>	<b>2017/18 TOTAL</b>	<b>2018/19 TOTAL</b>	<b>2019/20 TOTAL</b>	<b>2019/21 TOTAL</b>
HIGHWAY / ROADWAY / SIDEWALK	170,750,072	48,984,919	59,808,910	36,135,317	11,943,830	13,877,096
AVIATION	9,363,726	2,414,000	825,000	2,445,000	3,679,726	0
TRANSIT OPERATIONS EQUIPMENT & FACILITIES	31,948,804	4,654,767	4,715,305	4,775,552	9,099,103	8,704,077
MISCELLANEOUS	35,585,000	27,819,000	2,582,000	2,582,000	2,582,000	20,000
PLANNING	2,508,817	117,099	616,576	585,812	595,812	593,518
BRIDGE	77,851,632	9,100,737	3,494,305	63,411,242	944,000	901,348
TURNPIKE ENTERPRISE	373,271	44,920	328,351	0	0	0
SEAPORT	510,000	510,000	0	0	0	0
<b>GRAND TOTAL FROM ALL FUNDING SOURCES</b>	<b>328,891,322</b>	<b>93,645,442</b>	<b>72,370,447</b>	<b>109,934,923</b>	<b>28,844,471</b>	<b>24,096,039</b>
<b>PROJECT FUNDING SOURCE ESTIMATES BY JURISDICTION</b>	<b>JURISDICTION GRAND TOTAL</b>	<b>2016/17 TOTAL</b>	<b>2017/18 TOTAL</b>	<b>2018/19 TOTAL</b>	<b>2019/20 TOTAL</b>	<b>2019/21 TOTAL</b>
FEDERAL	101,618,389	12,821,661	15,159,028	54,087,733	12,026,571	7,523,396
STATE	208,841,884	74,549,028	55,095,645	47,580,600	15,716,643	15,899,968
STATE 100%	3,185,041	369,031	0	2,816,010	0	0
LOCAL	15,246,008	5,905,722	2,115,774	5,450,580	1,101,257	672,675
<b>GRAND TOTAL FROM ALL JURISDICTIONS</b>	<b>328,891,322</b>	<b>93,645,442</b>	<b>72,370,447</b>	<b>109,934,923</b>	<b>28,844,471</b>	<b>24,096,039</b>

### **B.3 Project Selection**

The selection of federally-funded projects within the St. Lucie TPO MPA for the TIP is consistent with Federal regulations [23 CFR 450.330(c)] and is carried out by the TPO in cooperation with FDOT and the transit operator. The TIP has been developed in coordination with the USDOT, FDOT, St. Lucie TPO Advisory Committees, local governments, port and aviation authorities, transit operators, and the general public as summarized in Section B.6 of the TIP.

For the TPO's FY 2016/17 – FY 2020/21 TIP, the project selection and TIP development process started in June 2015 with a meeting with staffs from the St. Lucie TPO, FDOT District 4, and the local governments to informally discuss the priority projects. The List of Priority Projects (LOPP) then was developed based on the LRTP and other plans as identified in Section B.4, local agency input, and public comments. The LOPP was reviewed by the St. Lucie TPO Advisory Committees and was adopted by the St. Lucie TPO Board and submitted to FDOT District 4 in August 2015. The LOPP was utilized by FDOT District 4 to develop their Draft Tentative Work Program for FY 2016/17 – FY 2020/21. The Draft Tentative Work Program was reviewed and endorsed by the Advisory Committees in September 2015 and by the Board in October 2015. The Final Tentative Work Program was received from FDOT in April of 2016. The Final Tentative Work Program is the primary component of the TIP. The TPO LOPP is reproduced in Section D of the TIP.

### **B.4 Consistency with Other Plans**

The projects in the TIP are based on the LRTP, the St. Lucie Transit Development Plan, the Transportation Disadvantaged Service Plan / Coordinated Public Transit – Human Services Transportation Plan, and other transportation plans of the St. Lucie TPO. These plans are cross-referenced in the LOPP, and the TIP projects are cross-referenced with the LRTP in the Project Index and TIP/LRTP Cross-Reference in Section A.2. The projects also are consistent with the St. Lucie County Airport Master Plan, the Port of Fort Pierce Master Plan, and the 2060 Florida Transportation Plan.

In addition, the TIP has been developed to be consistent with adopted local Comprehensive Plans including the St. Lucie County, City of Fort Pierce, City of Port St. Lucie, and St. Lucie Village Comprehensive Plans. The transportation network in the TPO MPA contains the traffic circulation elements included in the adopted St. Lucie County, City of Fort Pierce, City of Port St. Lucie, and St. Lucie Village Comprehensive Plans. Projections of future traffic volumes and levels of service were developed based on the Future Land Use Elements of the respective plans. The projections, as identified in the LRTP, served as a basis for determining the need for new or expanded transportation facilities and transportation management systems to support proposed development and to maintain or improve adopted level of service standards.

### **B.5 Project Priority Statement**

The projects selected in the TIP are based upon the TPO LOPP and the corresponding prioritization methodology and the goals, objectives and performance measures identified in Table 2-5 of the LRTP. The project prioritization was based on qualitative and quantitative analyses of the transportation projects in the TPO MPA which included the scoring and ranking of multimodal project priorities as identified in Table 3-5 of the LRTP. The project priorities were further refined with the development of transportation alternatives and scenarios planning as summarized in Chapter 5 of the LRTP and the consideration of public comment as summarized in Chapter 6 of the LRTP.

## **B.6 Public Involvement**

Public involvement in the development of the LOPP and the TIP is continuous, cooperative, and comprehensive and was conducted in accordance with the adopted Public Involvement Program (PIP) of the St. Lucie TPO and with Federal regulations [23 CFR 450.316 and 23 CFR 450.324(b)]. Reasonable opportunity to comment on the LOPP and the TIP was provided to all interested parties including, but not limited to, citizens, affected public agencies, public transit providers, freight shippers, private transportation providers, bicycle/pedestrian representatives, and the disabled. The process included those traditionally underserved and underrepresented consistent with the principles of Title VI. The process is followed for all projects funded in whole or part by the Federal Transit Administration (FTA) or the Federal Highway Administration (FHWA) pursuant to the Federal requirements.

Adequate and timely notice of public comment opportunities, the use of visualization techniques and electronic formats for the presentation of information, and convenient public meetings were incorporated into the public involvement process for the LOPP, Tentative Work Program, and the TIP. The notices and opportunities for public comment that were provided included the following:

- Display advertising of public meetings and comment opportunities in a daily local newspaper of general circulation.
- Posting of public meetings and comment opportunities on the TPO website.
- Providing notices of public meetings and comment opportunities to interested parties including citizens, affected public agencies, public transit providers, freight shippers, private transportation providers, bicycle/pedestrian representatives, and the disabled.
- Providing draft materials for review in person or by mail, fax or email.
- Conducting public meetings of the Advisory Committees and Board for the LOPP, Tentative Work Program and the TIP.
- Incorporating general public comment opportunities at the start of all public meetings.
- Providing comment cards at all public meetings.

All the comments that were received were considered in the preparation of the LOPP and TIP. An Example Public Comment Notice is reproduced in Appendix A.

## **B.7 TIP Amendments**

TIP Amendments are completed in accordance with applicable requirements [23 CFR 324 and 326] when a project is added or deleted, when the fiscal constraint of the TIP is impacted by a project, and/or when there are significant changes in the scope of a project. The amendment of the TIP includes the preparation of a TIP Amendment Form that summarizes the nature of the changes.

Prior to the adoption of a TIP amendment by the TPO Board, notice and public comment opportunities are provided regarding the amendment consistent with Section B.6. Upon adoption of the amendment by the TPO Board, the TIP Amendment Form is incorporated into Appendix E of the TIP.

## **B.8 Annual Listing of Obligated Federal Funding/Implemented Projects FY 2015/16**

The annual listing of implemented projects for which federal funds have been obligated in the preceding year has been made available for public review and is summarized in the following table:

FDOT NUMBER	DESCRIPTION PROJECT LIMITS	PROJECT WORK MIX	MILES LENGTH	2015 FUND TOTAL	FUND CODE	PRELIMINARY ENGINEERING	RIGHT-OF-WAY	CONSTRUCTION	GRANTS MISC.
230262 2	SR-70/OKEECHOBEE ROAD	ADD LANES		-	ACNH	-	-	-	-
	OKEECHOBEE/ST LUCIE C/L TO MP 5.871	RECONSTRUCT		-	ACNP	-	-	-	-
				(69,860)	ACSA	-	-	(69,860)	-
				(25,568)	EB	-	-	(25,568)	-
				275,105	NH	-	-	275,105	-
				179,677	NHPP	-	-	179,677	-
		TOTAL	5.87	179,677		-	-	179,677	-
230338 4	SR-614/INDRIO ROAD	ADD LANES		-	ACSA	-	-	-	-
	WEST OF I-95	RECONSTRUCT		64,742	SA	-	-	-	64,742
	TO EAST OF SR-670/EMERSON AV			735,928	SU	-	735,928	-	-
		TOTAL	2.709	800,640		-	735,928	-	64,742
231440 2	W. MIDWAY RD/CR-712	ADD LANES		919,771	EB	48,490	866,162	-	5,119
	S. 25TH ST/SR-615 TO SR-5/US-1	RECONSTRUCT		86,419	SA	21,231	68,864	-	(3,676)
				-	ACSU	-	-	-	-
				-	SA	-	-	-	-
				1,660,240	SU	-	1,660,240	-	-
		TOTAL	1.915	2,666,430		69,721	2,595,266	-	1,443
410844 1	CROSSTOWN PARKWAY	PD&E/EMO		-		-	-	-	-
	MANTH LANE TO SR-5/US-1			25,951	EB	25,951	-	-	-
				-	SA	-	-	-	-
		TOTAL	1.094	25,951		25,951	-	-	-
410844 4	CROSSTOWN PARKWAY	NEW BRIDGE		15,000	EB	-	15,000	-	-
	MANTH LANE TO SR-5/US-1	CONSTRUCTION		3,500,000	EBBP	-	3,500,000	-	-
				197,288	SA	-	197,288	-	-
				1,500,000	SABR	-	1,500,000	-	-
		TOTAL		5,212,288		-	5,212,288	-	-
410844 5	CROSSTOWN PARKWAY	NEW BRIDGE		-	HPP	-	-	-	-
	MANTH LANE TO SR-5/US-1	CONSTRUCTION		-	ACSA	-	-	-	-
				-	CM	-	-	-	-
				20,532	EB	-	-	20,532	-
				1,150	SA	-	-	1,150	-
				-	SA	-	-	-	-
				-	SABR	-	-	-	-
				-	SU	-	-	-	-
		TOTAL	2.651	21,682		-	-	21,682	-
413046 1	I-95/SR-9	ADD LANES		-	ACNH	-	-	-	-
	SR-70/OKEECHOBEE RD	REHABILITATE		-	ACSA	-	-	-	-
	TO SR-614/INDRIO RD	PAVEMENT		(28,975)	EB	-	-	(28,975)	-
				137,906	NH	-	-	137,906	-
				32,443	NHPP	-	-	32,443	-
				897,496	SA	-	-	897,496	-
		TOTAL	15.026	1,038,870		-	-	1,038,870	-
413047 1	I-95/SR-9	ADD LANES		2,646		-	-	2,646	-
	SR-614/INDRIO	REHABILITATE PVMNT		-	EB	-	-	-	-
	TO IRC/ST LUCIE CO/LINE			-	SA	-	-	-	-
		TOTAL	4.069	2,646		-	-	2,646	-
423022 1	CR-68/ORANGE AVENUE	PAVE SHOULDERS		138,935	EB	-	-	142,586	(3,651)
	E. OF GRAVES ROAD			4,149	SA	(4,253)	-	5,620	2,782
	TO W. OF SR-713/KINGS H			-		-	-	-	-
		TOTAL	5.62	143,084		(4,253)	-	148,206	(869)

FDOT NUMBER	DESCRIPTION PROJECT LIMITS	PROJECT WORK MIX	MILES LENGTH	2015 FUND TOTAL	FUND CODE	PRELIMINARY ENGINEERING	RIGHT-OF- WAY	CONSTRUCTION	GRANTS MISC.
427656 1	MELALEUCA BLVD- PH 1 CAMDEN STREET TO BERKSHIRE	SAFETY PROJECT SIDEWALK		6,404	SA	6,404	-	-	-
		TOTAL	0.732	6,404		6,404	-	-	-
427656 2	MELALEUCA BLVD- PH 2 BERKSHIRE BLVD TO GREEN RIVER PARKWAY	SAFETY PROJECT SIDEWALK		5,845	EB	5,845	-	-	-
		TOTAL	0.535	12,342	TALU	-	-	6,497	-
						5,845	-	6,497	-
429631 1	BAYSHORE BOULEVARD PRIMA VISTA BLVD. TO SELVITZ RD	SIDEWALK		56,848	TALU	-	-	56,848	-
				1,150	EB	-	-	1,150	-
				15,000	SA	-	-	15,000	-
				16,090	SU	-	-	16,090	-
		TOTAL	1.359	89,088		-	-	89,088	-
429936 2	SR- A1A NORTH BRIDGE #940045 OVER ICWW	BRIDGE REPLACEMENT		863,406	EB	863,406	-	-	-
				78,953	SA	78,953	-	-	-
				1,017,946	SABR	1,017,946	-	-	-
		TOTAL	1.00	1,960,305		1,960,305	-	-	-
	HAVANA AVENUE			133,842	TALT	-	-	133,842	-
				186,482	TALU	-	-	186,482	-
	KAUFMAN AVENUE TO SOUTH 13TH STREET			14,121	TALT	-	-	14,121	-
				2,853	TALU	-	-	2,853	-
		TOTAL	1.246	337,298		-	-	337,298	-
431735 1	SAVONA BLVD SW BECKER ROAD TO SW GATLIN BLVD	SAFETY PROJECT SIDEWALK		697,925	TALT	(1,177)	-	699,102	-
				887,710	SR2S	-	-	887,710	-
				60,648	SR2S	-	-	60,648	-
		TOTAL	3.72	1,646,283		(1,177)	-	1,647,460	-
431738 1	DARWIN BLVD SW BECKER RD. TO SW PAAR DR.	SIDEWALK		4,000	SA	4,000	-	-	-
				30,625	TALT	-	-	30,625	-
				912,059	TALT	1,417	-	910,642	-
				19,133	TALU	-	-	19,133	-
		TOTAL	1.248	965,817		5,417	-	960,400	-
431752 1	PORT ST LUCIE BLVD BECKER ROAD TO DARWIN BLVD	ADD LANES RECONSTRUCT		-	SA	-	-	-	-
				10,968		10,968	-	-	-
		TOTAL	2.866	10,968		10,968	-	-	-
431752 2	PORT ST LUCIE BLVD PAAR DRIVE ROAD TO DARWIN BLVD	ADD LANES RECONSTRUCT		4,000	EB	4,000	-	-	-
				185,508	SA	185,508	-	-	-
				374,191	SU	374,191	-	-	-
		TOTAL	1.946	563,699		563,699	-	-	-
434009 1	SUNRISE BLVD FROM IBIS AVE TO EGRET AVE	EMERGENCY OPERATIONS		177	ER13	-	-	177	-
				3,645	ER13	-	-	-	3,645
				(1,337)	ER13	-	-	-	(1,337)
		TOTAL	.192	2,485		-	-	177	2,308
434360 1	CR- 712A/MCCARTY RD. BRDG #940031 OVER TEN MILE CREEK	BRIDGE REPLACEMENT		5,348	SA	5,348	-	-	-
				132,554	SABR	132,554	-	-	-
				(1,353)	SABR	-	-	-	(1,353)
				1,188	SU	-	-	-	1,188
		TOTAL	0.12	137,737		137,902	-	-	(165)

FDOT NUMBER	DESCRIPTION PROJECT LIMITS	PROJECT WORK MIX	MILES LENGTH	2015 FUND TOTAL	FUND CODE	PRELIMINARY ENGINEERING	RIGHT-OF- WAY	CONSTRUCTION	GRANTS MISC.
4347311	FLORESTA DRIVE BETWEEN NARANJA AVENUE & VERANDA AVE	EMERGENCY OPERATIONS		(221) 1,248	ER13 ER13	- -	- -	-221 1,248	
		TOTAL	0	8,186 9,213	ER13	- -	- -	8,186 1,027	8,186 8,186
434732 1	AIROSO BOULEVARD @ SAGAMORE AVE	EMERGENCY OPERATIONS WASHOUT REPAIR		7,673 1,309	ER13 ER13		1,309		7,673
		TOTAL		8,982		1,309			7,673
435263 1	SELVITZ ROAD BAYSHORE BLVD TO NORTH MACEDO BLVD.	SIDEWALK		5,000	TALT	5,000			
		TOTAL	.420	5,000		5,000			
TOTAL HIGHWAYS			38.574	15,398,124		2,672,602	8,543,482	4,098,752	83,288
423604 2	ST. LUCIE UPWP FY 2014/2015 & 2015/2016	TRANSPORTATION PLANNING				772,471	-	-	-
		TOTAL PLANNING		772,471	PL	772,471	-	-	-
428765 1	SR2N PROGRAM PURCHASE MATERIALS DISTRIBUTION TO SCHOOLS	MISCELLANEOUS		(11)	SRN2	-	-	-	(11)
432846 4	ST. LUCIE COUNTY EMERGENCY SIGNAL REPAIRS CITY OF PORT ST. LUCIE	MISCELLANEOUS		1,360	ER14	-	-	-	1,360
		TOTAL MISCELLANEOUS		1,349		-	-	-	1,349
GRAND TOTAL			34.505	\$16,171,944		\$3,445,073	\$8,543,482	\$4,098,752	\$84,637
			MILES	2015		PRELIMINARY	RIGHT-OF-	CONSTRUCTION	GRANTS
			LENGTH	FUND TOTAL		ENGINEERING	WAY		MISC.

FTA GRANT NUMBER	COUNTY	FTA GRANTEE	FEDERAL FUND CODE	FTA WORK TYPE	FTA PROJECT DESCRIPTION	TOTAL FTA FUNDS IN TIP	TOTAL FEDERAL FUNDS OBLIGATED	TOTAL LOCAL FUNDS
TBD	SLC	SLC	5307	Capital/Operating	Capital/Operating	\$13,470,000	\$2,319,582	\$1,739,693
TBD	SLC	SLC	5339	Bus and Bus Facilities	Capital	\$987,000	\$209,344	-
TBD	SLC	SLC	5311	Operating	Operating	\$354,117	\$55,188	\$55,188



## **B.9 Certifications**

To ensure Federal requirements are being met, the FHWA and FTA conduct Federal certification reviews on a quadrennial basis of the urbanized areas of TPOs/MPOs which also are designated by census as Transportation Management Areas (TMAs) because the population exceeds 200,000 people. The urbanized area of the St. Lucie TPO is designated as the Port St. Lucie TMA. The last Federal review of the TMA was completed in September 2013 and resulted in six Noteworthy Practices being identified for the St. Lucie TPO. No Corrective Actions were identified for the St. Lucie TPO as a result of the review.

The TPO and FDOT also perform joint certification reviews annually to ensure that State and Federal requirements are being met. The last joint certification review was completed in May 2016 which resulted in the joint certification of the St. Lucie TPO. Support documentation concerning the Federal and joint certification reviews is on file at the St. Lucie TPO offices and available for review during normal business hours.

## **B.10 Congestion Management Process (CMP)**

The development and implementation of a CMP is a requirement to be eligible for Federal funding. CMP Box Funds in the amount of \$300,000 - \$400,000 annually have been established by the St. Lucie TPO. Beyond the five fiscal years of the TIP, the LRTP continues to allocate approximately \$3.25 million in funding towards the CMP on a yearly basis through 2040.

The overall purpose of the St. Lucie TPO CMP is to create a better quality of life for St. Lucie residents and visitors through lowering travel delay, reducing harmful emissions, and improving safety. The CMP identifies areas with congestion or safety issues, develops strategies to address the issues, and prioritizes projects based a ranking criteria.

The St. Lucie TPO CMP was adopted in 2011, and a two-tiered approach (Tier I and Tier II) was utilized in the CMP to identify projects. The Tier I analysis provided a system-wide screening for areas of concern. The Tier II analysis included a detailed evaluation of the identified areas of concern. Based on the results of the Tier II evaluation, CMP projects were identified, and a project scoring criteria and the basis for the CMP Implementation Plan were developed.

Incorporating multimodal performance measures, the CMP Implementation Plan utilizes both traditional and non-traditional strategies to address the areas of concern, to reduce vehicle miles traveled, and to consider climate adaptation and proposes improvements which support multimodal elements and safety. The CMP projects from the CMP Implementation Plan that are not funded in the TIP may be added to CMP List of the TPO's LOPP for future funding with the CMP Box Funds.

**B.11 Transportation Disadvantaged (TD) Program**

TD services are facilitated by the St. Lucie TPO pursuant to Florida Statute 427.015. The projects and costs of the St. Lucie TPO TD Program are summarized in the following:

**DRAFT**  
**Commission for the Transportation Disadvantaged**  
**Trip & Equipment Grant Allocations**  
**FY 2016-2017**

COUNTY	TRIP/EQUIP FUNDS FM/Job # 43202718401	LOCAL TRIP/EQUIP MATCH	TOTAL TRIP/EQUIP FUNDS	VOLUNTARY DOLLARS FM/Job # 43202818401	VOLUNTARY DOLLARS LOCAL MATCH	TOTAL VOLUNTARY DOLLARS	PLANNING GRANT ALLOCATION	TOTAL ESTIMATED PROJECT FUNDING
Saint Lucie	\$546,475	\$60,719	\$607,194	\$102	\$12	\$114	\$24,862	\$632,170

**B.12 Transportation Regional Incentive Program (TRIP)**

In 2005, the Florida Legislature enacted the Florida TRIP through Senate Bill 360. The stated purpose of the program is to encourage regional planning by providing state matching funds for improvements to regionally-significant transportation facilities identified and prioritized by regional partners.

According to FDOT, two primary program requirements are as follows:

- 1) Eligible recipients must be a partner, through an Interlocal Agreement, to a regional transportation planning entity; and,
- 2) The partners must represent a regional transportation planning area and develop a plan that identifies and prioritizes regionally significant facilities.

To satisfy the application requirements for TRIP funding, an Interlocal Agreement was executed by the St. Lucie TPO, Martin MPO, and Indian River MPO to create a regional transportation planning entity known as the Treasure Coast Transportation Council (TCTC). The TCTC subsequently adopted a plan to identify and prioritize regionally significant facilities for the selection of projects for TRIP funding. This plan subsequently was updated in 2016.

St. Lucie TPO projects currently programmed include \$417,174 of TRIP funding. The Port St. Lucie Boulevard project (#4317522) is receiving \$45,451 in TRIP funding, and the SR-9/I-95 @ St. Lucie West Boulevard project (#4353371) is receiving \$371,723 in TRIP funding.

**C. DETAILED PROJECT LISTINGS**

**Section C 1 - Highway/Roadway/Sidewalk Projects**

---

**CROSTOWN PARKWAY**

**4108444**

**Non-SIS**

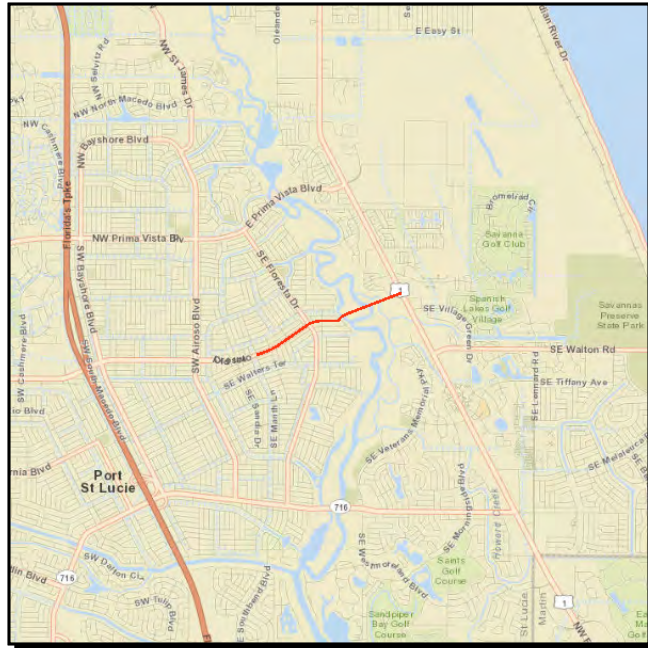

**Project Description:** Details: Right-of-way acquisition to construct bridge over St. Lucie River to connect Crosstown Parkway to US-1

**Work Summary:** RIGHT OF WAY ACTIVITIES **From:** MANTH LANE

**To:** SR-5/US-1

**Lead Agency:** CITY OF PORT ST LUCIE **Length:** 2.651 mi

Phase	Fund Source	2016/17	2017/18	2018/19	2019/20	2020/21	Total
ROW	ACBR	761,000	398,723	1,000,000	1,034,607	0	<b>3,194,330</b>
ROW	TRWR	369,031	0	0	0	0	<b>369,031</b>
ROW	LFP	35,000	30,000	20,000	251,028	0	<b>336,028</b>
ROW	SA	39,785	15,000	10,000	0	0	<b>64,785</b>
ROW	CIGP	513,407	30,000	20,000	251,028	0	<b>814,435</b>
<b>Total</b>		<b>1,718,223</b>	<b>473,723</b>	<b>1,050,000</b>	<b>1,536,663</b>	<b>0</b>	<b>4,778,609</b>

**Prior Year Cost:** 27,161,087

**Future Year Cost:** 0

**Total Project Cost:** 31,939,696

**LRTP:** Page 7-1

**I-95 AT ST. LUCIE WEST BLVD. INTERCHANGE**

**4353371**

**SIS**

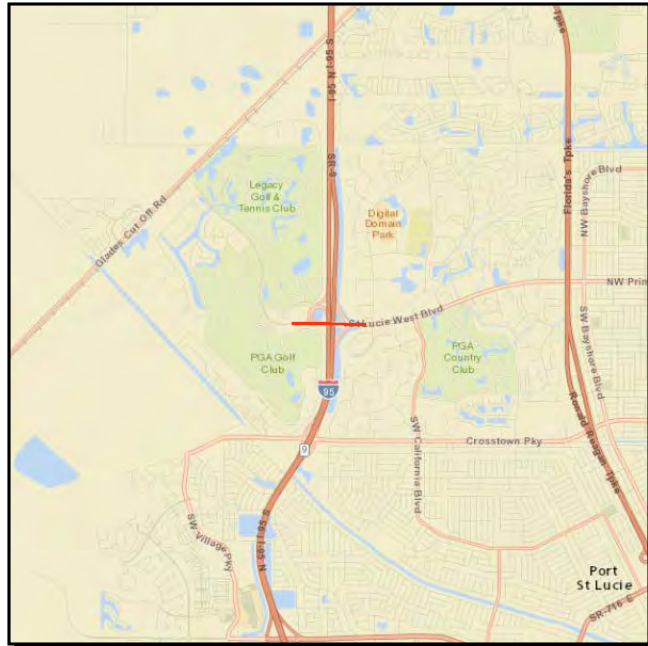

**Project Description:** CONSTRUCT 3 LANE EB BRIDGE, WITH SHOULDER TO ACCOMMODATE WIDENING TO 6 LANES, ADD BICYCLE LANES AND

**Work Summary:** **From:** Interchange  
**To:** Interchange

**Lead Agency:** Managed by FDOT **Length:** 2.743 MI

Phase	Fund Source	2016/17	2017/18	2018/19	2019/20	2020/21	Total
CST	TRWR	0	0	2,816,010	0	0	2,816,010
CST	DIH	0	0	93,499	0	0	93,499
CST	DDR	0	0	1,165,278	0	0	1,165,278
CST	TRIP	0	0	371,723	0	0	371,723
CST	LF	0	0	3,111,822	0	0	3,111,822
<b>Total</b>		<b>0</b>	<b>0</b>	<b>7,558,332</b>	<b>0</b>	<b>0</b>	<b>7,558,332</b>

**Prior Year Cost:** 501,581  
**Future Year Cost:** 0  
**Total Project Cost:** 8,059,913  
**LRTP:** Page 6-2

**I-95 BRIDGE DECK REPLACEMENT**

**4366461**

**SIS**



**Project Description:** BRIDGE DECK REPLACEMENT ON I-95 OVER GATLIN BLVD. AND OVER MIDWAY RD

**Work Summary:** BRIDGE REHABILITATION **From:** GATLIN BLVD

**To:** MIDWAY RD

**Lead Agency:** Managed by FDOT **Length:** 7.894

Phase	Fund Source	2016/17	2017/18	2018/19	2019/20	2020/21	Total
INC	BRRP	0	300,000	0	0	0	300,000
<b>Total</b>		<b>0</b>	<b>300,000</b>	<b>0</b>	<b>0</b>	<b>0</b>	<b>300,000</b>

**Prior Year Cost:** 12,696,069

**Future Year Cost:** 0

**Total Project Cost:** 12,996,069

**LRTP:** Page 6-2



**I-95 BRIDGE DECK REPLACEMENT**

**4366171**

**SIS**



**Project Description:** BRIDGE DECK REPLACEMENT ON I-95 OVER CR-709 & FEC R/R (BRDG# 940115 & 940116) AND OVER TEN MILE CREEK

**Work Summary:** BRIDGE REHABILITATION **From:** CR-709 & FEC R/R

**To:** TEN MILE CREEK

**Lead Agency:** Managed by FDOT **Length:** 3.821

Phase	Fund Source	2016/17	2017/18	2018/19	2019/20	2020/21	Total
CST	BRRP	23,189,931	0	0	0	0	<b>23,189,931</b>
CST	DIH	128,125	0	0	0	0	<b>128,125</b>
INC	BRRP	0	0	300,000	0	0	<b>300,000</b>
<b>Total</b>		<b>23,318,056</b>	<b>0</b>	<b>300,000</b>	<b>0</b>	<b>0</b>	<b>23,618,056</b>

**Prior Year Cost:** 1,318,910  
**Future Year Cost:** 0  
**Total Project Cost:** 24,936,966  
**LRTP:** Page 6-2

**INDRIO ROAD / SR-614**

**2303384**

**Non-SIS**

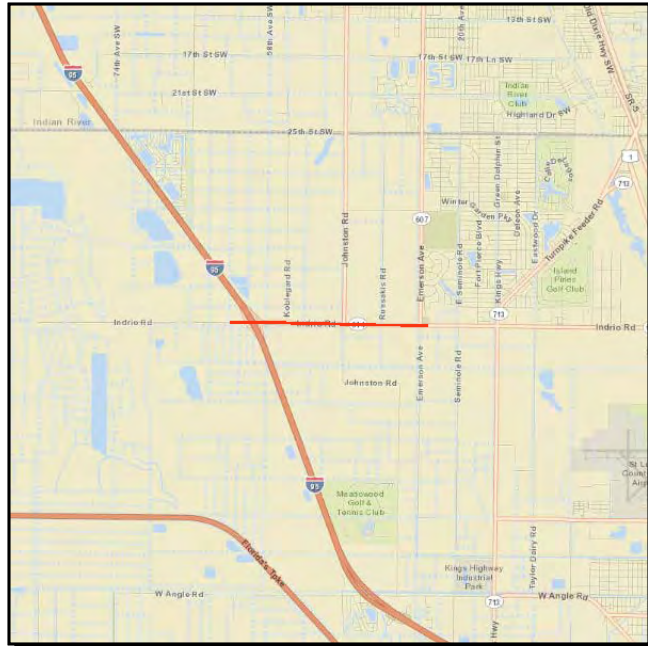

**Project Description:** Add 2 travel lanes, bicycle lanes and sidewalks

**Work Summary:** ADD LANES & RECONSTRUCT

**From:** WEST OF SR-9/I-95

**To:** EAST OF SR-670/EMERSON AVE

**Lead Agency:** FDOT

**Length:** 2.709 miles

Phase	Fund Source	2016/17	2017/18	2018/19	2019/20	2020/21	Total
ROW	DDR	10,000	0	0	0	0	<b>10,000</b>
ROW	DS	209,610	0	642,000	104,963	0	<b>956,573</b>
ROW	DIH	243,094	0	0	0	0	<b>243,094</b>
ROW	SU	466,690	523,520	0	0	0	<b>990,210</b>
<b>Total</b>		<b>929,394</b>	<b>523,520</b>	<b>642,000</b>	<b>104,963</b>	<b>0</b>	<b>2,199,877</b>

**Prior Year Cost:** 40,717,370

**Future Year Cost:** 0

**Total Project Cost:** 42,917,247

**LRTP:** Page 6-2

**KING'S HIGHWAY / SR-713**

**2302566**

**SIS**



**Project Description:** Add 2 travel lanes, bicycle lanes, and sidewalks

**Work Summary:** ADD LANES & RECONSTRUCT  
**From:** 800' S OF SR-70  
**To:** NORTH OF PICOS ROAD

**Lead Agency:** FDOT  
**Length:** 2.273 MI

Phase	Fund Source	2016/17	2017/18	2018/19	2019/20	2020/21	Total
ROW	DDR	293,417	455,898	0	0	0	<b>749,315</b>
ROW	DS	3,804,884	0	397,887	4,288,696	0	<b>8,491,467</b>
ROW	DIH	46,031	36,962	25,725	0	0	<b>108,718</b>
CST	SU	0	1,082,180	0	0	0	<b>1,082,180</b>
CST	DS	0	22,495,882	0	0	0	<b>22,495,882</b>
CST	DIH	0	238,366	0	0	0	<b>238,366</b>
CST	DDR	0	17,159,534	0	0	0	<b>17,159,534</b>
INC	DDR	0	0	400,000	0	0	<b>400,000</b>
<b>Total</b>		<b>4,144,332</b>	<b>41,468,822</b>	<b>823,612</b>	<b>4,288,696</b>	<b>0</b>	<b>50,725,462</b>

**Prior Year Cost:** 4,994,502  
**Future Year Cost:** 0  
**Total Project Cost:** 55,719,964  
**LRTP:** Page 6-2

**KING'S HIGHWAY / SR-713**

**2302567**

**Non-SIS**

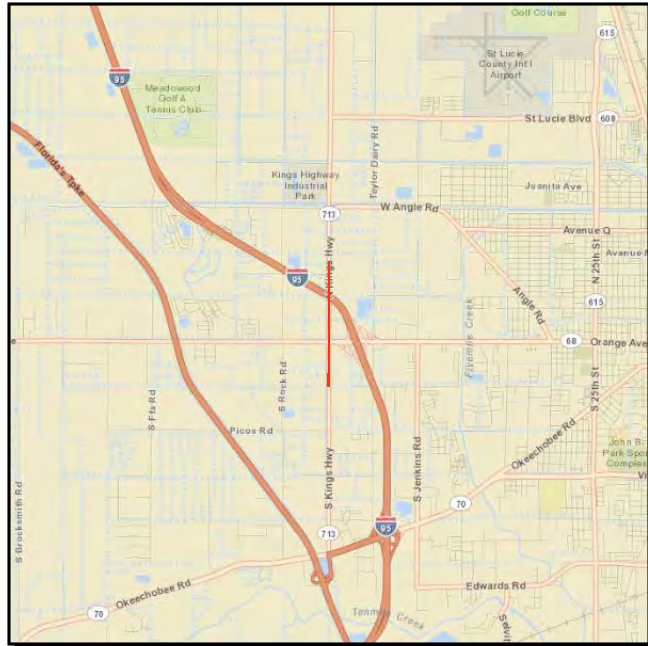

**Project Description:** Add 2 travel lanes, bicycle lanes, and sidewalks

**Work Summary:** ADD LANES & RECONSTRUCT  
**From:** NORTH OPF PICOS ROAD  
**To:** NORTH OF I-95 OVERPASS

**Lead Agency:** FDOT  
**Length:** 1.410 MI

Phase	Fund Source	2016/17	2017/18	2018/19	2019/20	2020/21	Total
ROW	DDR	1,113,366	682,770	973,000	0	0	2,769,136
ROW	DS	1,047,365	0	0	747,308	0	1,794,673
ROW	DIH	89,858	0	0	0	0	89,858
ENV	DDR	0	5,000	0	0	0	5,000
CST	DIH	0	0	108,727	0	0	108,727
CST	DDR	0	0	2,145,816	0	0	2,145,816
CST	DS	0	0	16,364,277	0	0	16,364,277
<b>Total</b>		<b>2,250,589</b>	<b>687,770</b>	<b>19,591,820</b>	<b>747,308</b>	<b>0</b>	<b>23,277,487</b>

**Prior Year Cost:** 851,392  
**Future Year Cost:** 0  
**Total Project Cost:** 24,128,879  
**LRTP:** Page 6-2

**KING'S HIGHWAY / SR-713**

**2302568**

**Non-SIS**

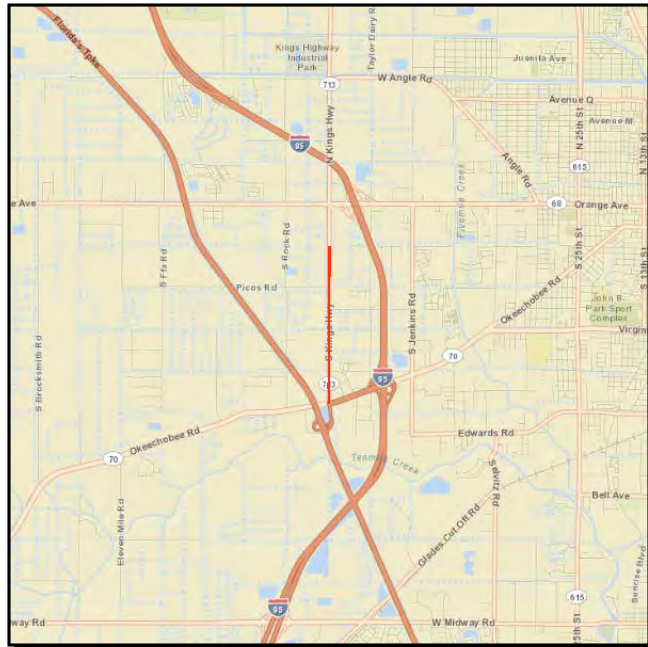

**Project Description:** LANDSCAPE PROJECT FOR PROJECT 2302566 KING'S HIGHWAY / SR-713

**Work Summary:** LANDSCAPING  
**From:** 800' S OF SR-70  
**To:** N OF PICOS RD

**Lead Agency:** Managed by FDOT  
**Length:** 1.890 MI

Phase	Fund Source	2016/17	2017/18	2018/19	2019/20	2020/21	Total
PE	DDR	0	0	126,500	0	0	126,500
PE	DIH	0	0	10,000	0	0	10,000
CST	DIH	0	0	0	0	30,521	30,521
CST	DDR	0	0	0	0	425,819	425,819
<b>Total</b>		<b>0</b>	<b>0</b>	<b>136,500</b>	<b>0</b>	<b>456,340</b>	<b>592,840</b>

**Prior Year Cost:** 0  
**Future Year Cost:** 0  
**Total Project Cost:** 592,840  
**LRTP:** Page 6-2



**KING'S HIGHWAY / SR-713**

**4241431**

**Non-SIS**

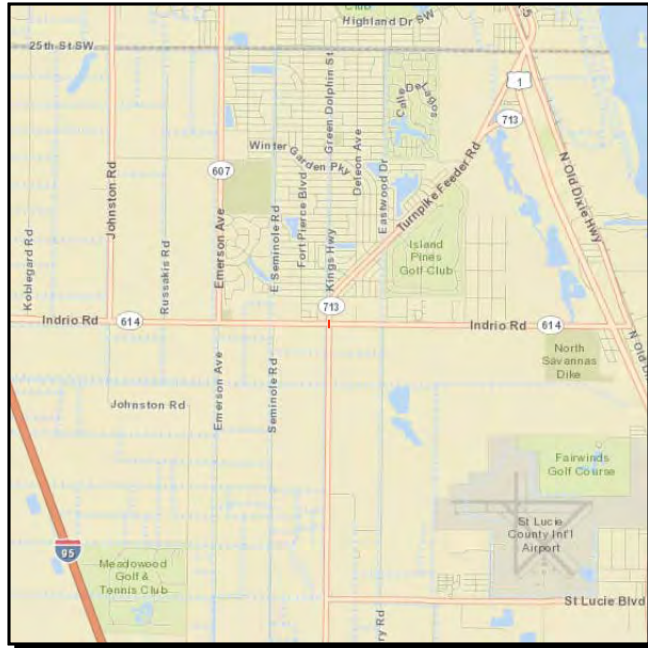

**Project Description:** Right-of-way acquisition for add turn lanes at King's Hwy @ Indrio Rd intersection improvement

**Work Summary:** ADD TURN LANE(S) **From:** Intersection  
**To:** Intersection

**Lead Agency:** FDOT **Length:** 1.084 mi

Phase	Fund Source	2016/17	2017/18	2018/19	2019/20	2020/21	Total
ROW	LFP	553,209	1,212,823	1,323,720	0	0	<b>3,089,752</b>
ROW	CIGP	452,300	1,212,823	1,323,720	0	0	<b>2,988,843</b>
<b>Total</b>		<b>1,005,509</b>	<b>2,425,646</b>	<b>2,647,440</b>	<b>0</b>	<b>0</b>	<b>6,078,595</b>

**Prior Year Cost:** 7,630,087  
**Future Year Cost:** 0  
**Total Project Cost:** 13,708,682  
**LRTP:** Page 6-2

**KING'S HIGHWAY / SR-713**

**4241432**

**Non-SIS**

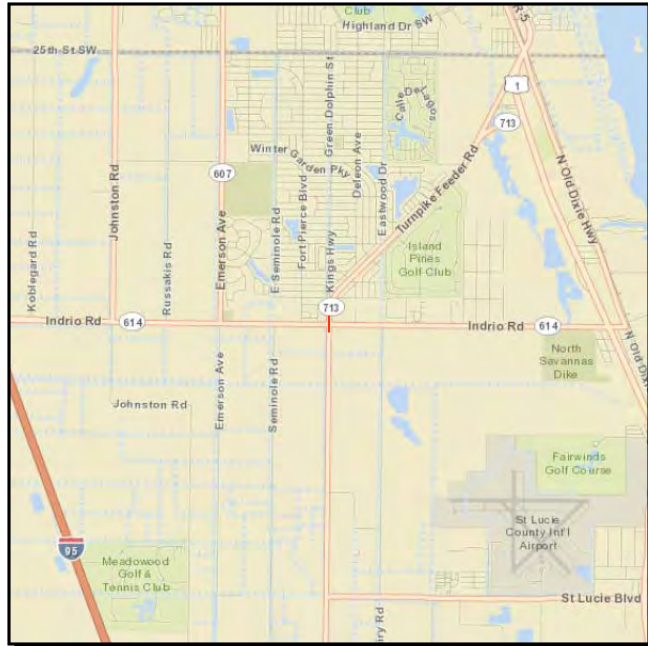

**Project Description:** Construction of add turn lanes at King's Hwy @ Indrio Rd intersection improvement.

**Work Summary:** **From:** INTERSECTION  
**To:** INTERSECTION

**Lead Agency:** Managed by FDOT **Length:** .000

Phase	Fund Source	2016/17	2017/18	2018/19	2019/20	2020/21	Total
CST	LFP	1,987,554	0	0	0	0	1,987,554
CST	CIGP	1,987,554	0	0	0	0	1,987,554
<b>Total</b>		<b>3,975,108</b>	<b>0</b>	<b>0</b>	<b>0</b>	<b>0</b>	<b>3,975,108</b>

**Prior Year Cost:** 13,737,555  
**Future Year Cost:** 0  
**Total Project Cost:** 17,712,663  
**LRTP:** Page 6-2





**MIDWAY ROAD / CR-712**

**2314402**

**Non-SIS**

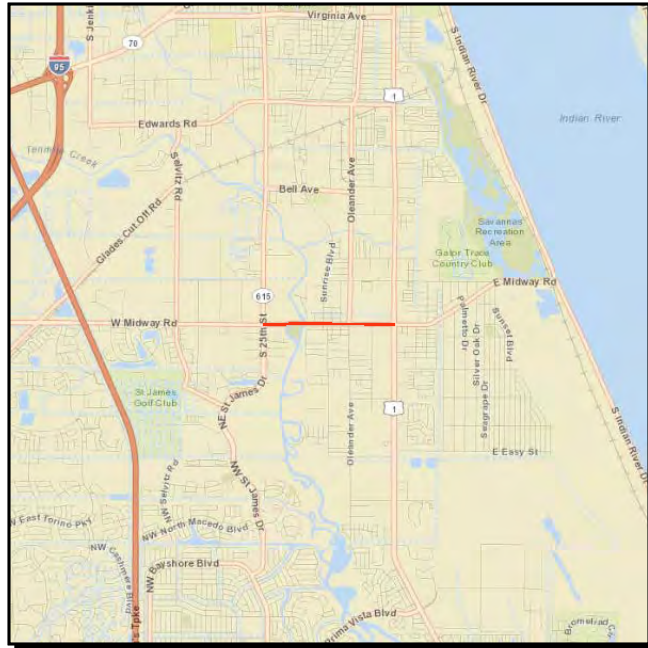

**Project Description:** Construction to widen road from 2 to 4 lanes with bike lanes, sidewalks, landscaping

**Work Summary:** ADD LANES & RECONSTRUCT **From:** S. 25TH ST/SR-615

**To:** SR-5/US-1

**Lead Agency:** FDOT **Length:** 1.647 mi

Phase	Fund Source	2016/17	2017/18	2018/19	2019/20	2020/21	Total
ROW	SU	4,699,255	1,834,356	1,546,484	894,383	0	<b>8,974,478</b>
ROW	SA	92,680	0	1,158,203	263,821	0	<b>1,514,704</b>
INC	SU	0	420,000	0	0	0	<b>420,000</b>
<b>Total</b>		<b>4,791,935</b>	<b>2,254,356</b>	<b>2,704,687</b>	<b>1,158,204</b>	<b>0</b>	<b>10,909,182</b>

**Prior Year Cost:** 64,247,898

**Future Year Cost:** 0

**Total Project Cost:** 75,157,080

**LRTP:** Page 6-2

**MIDWAY ROAD / CR-712**

**2314403**

**Non-SIS**

**Project Description:** WIDEN 2-4 LANES AND ADD BICYCLE LANES AND SIDEWALKS

**Work Summary:** PD&E/EMO STUDY      **From:** GLADES CUT OFF ROAD

**To:** SELVITZ ROAD

**Lead Agency:** Managed by FDOT      **Length:** 1.592 MI

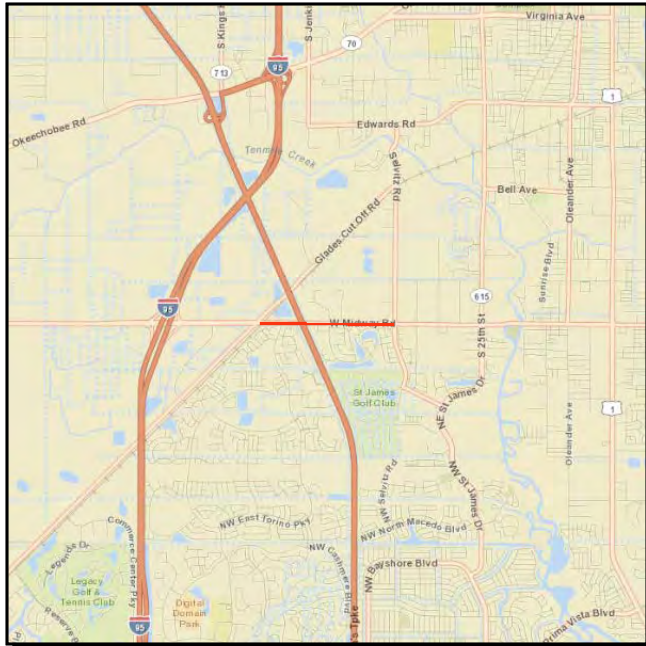

Phase	Fund Source	2016/17	2017/18	2018/19	2019/20	2020/21	Total
ROW	LFP	10,000	0	0	0	0	10,000
PE	LFP	2,150,000	0	0	0	0	2,150,000
<b>Total</b>		<b>2,160,000</b>	<b>0</b>	<b>0</b>	<b>0</b>	<b>0</b>	<b>2,160,000</b>

**Prior Year Cost:** 1,650,927  
**Future Year Cost:** 0  
**Total Project Cost:** 3,810,927  
**LRTP:** Page 6-5

**OKEECHOBEE ROAD / SR-70**

**4289841**

**SIS**

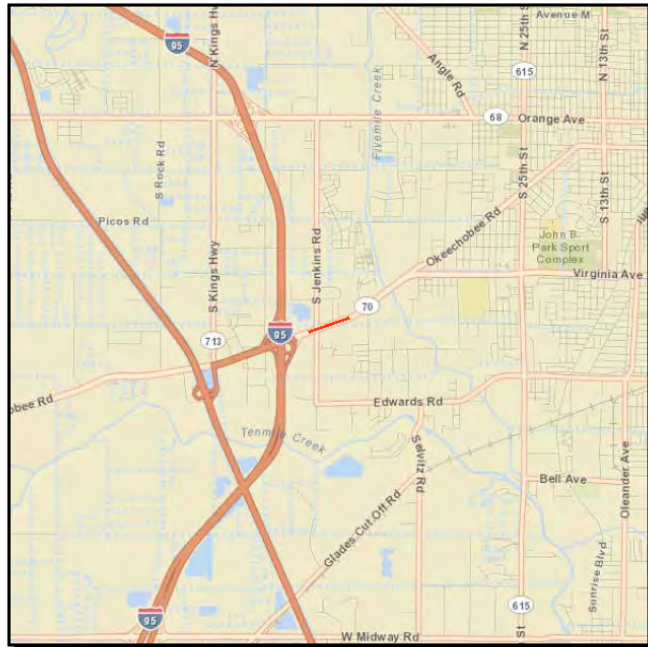

**Project Description:** WIDEN FROM 6 TO 8 LANES, ADD BICYCLE LANES AND SIDEWALKS

**Work Summary:** ADD LANES & REHABILITATE PVMNT  
**From:** 900' W OF JENKINS RD  
**To:** 2700' E OF JENKINS RD

**Lead Agency:** FDOT  
**Length:** 1.486 mi

Phase	Fund Source	2016/17	2017/18	2018/19	2019/20	2020/21	Total
ROW	DDR	0	145,046	0	0	0	145,046
ROW	DS	0	759,060	0	0	0	759,060
<b>Total</b>		<b>0</b>	<b>904,106</b>	<b>0</b>	<b>0</b>	<b>0</b>	<b>904,106</b>

**Prior Year Cost:** 10,864,150  
**Future Year Cost:** 0  
**Total Project Cost:** 11,768,256  
**LRTP:** Page 7-1

**PAAR DRIVE**

**4381301**

**Non-SIS**

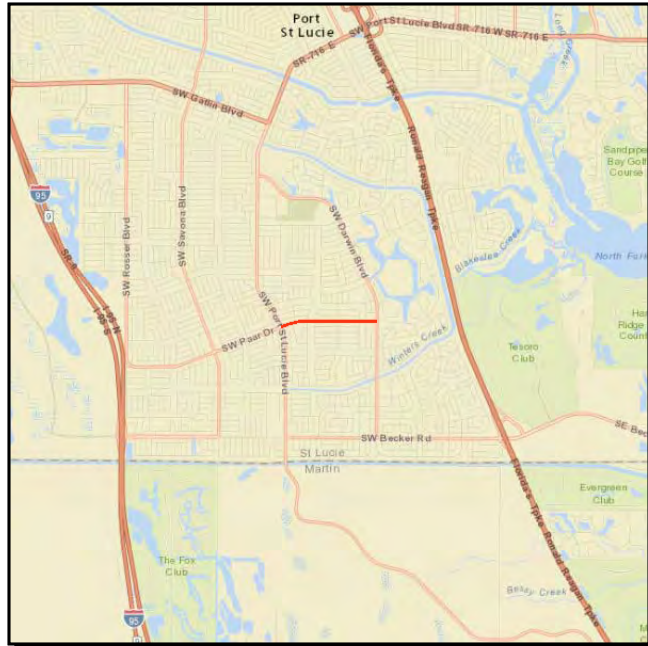

**Project Description:** ADD SIDEWALK ON NORTH SIDE OF PAAR DRIVE FROM SW PORT ST.LUCIE BLVD TO SW DARWIN BLVD

**Work Summary:** SIDEWALK  
**From:** SW PORT ST.LUCIE BLVD  
**To:** SW DARWIN BLVD

**Lead Agency:** Managed by FDOT  
**Length:** 1.034

Phase	Fund Source	2016/17	2017/18	2018/19	2019/20	2020/21	Total
PE	TALU	5,000	0	0	0	0	<b>5,000</b>
CST	TALT	0	0	79,676	0	0	<b>79,676</b>
CST	LFP	0	0	130,840	0	0	<b>130,840</b>
CST	TALU	0	0	304,508	0	0	<b>304,508</b>
<b>Total</b>		<b>5,000</b>	<b>0</b>	<b>515,024</b>	<b>0</b>	<b>0</b>	<b>520,024</b>

**Prior Year Cost:** 0  
**Future Year Cost:** 0  
**Total Project Cost:** 520,024  
**LRTP:** Page 7-1

**PORT ST. LUCIE BOULEVARD**

**4317522**

**Non-SIS**

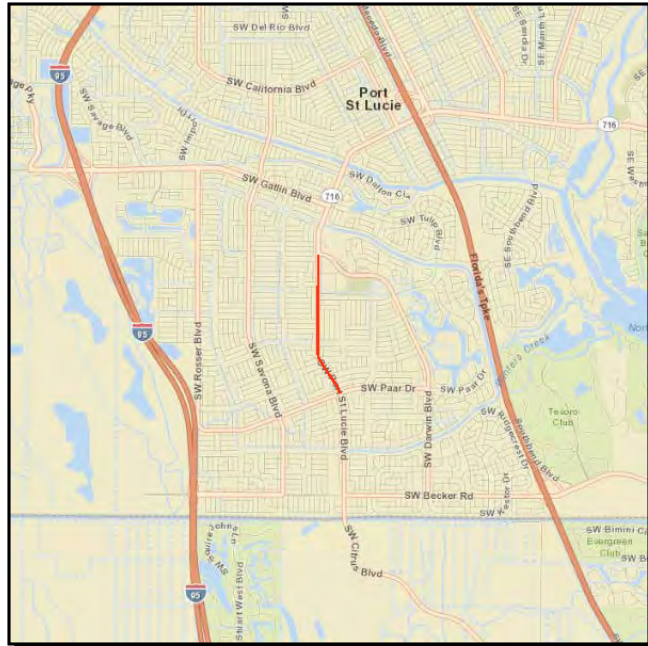

**Project Description:** ADD 2 LANES, BIKE LANES AND SIDEWALKS ON PORT ST LUCIE BLVD FROM PAAR DRIVE TO DARWIN BLVD

**Work Summary:** ADD LANES & RECONSTRUCT **From:** FROM PAAR DRIVE

**To:** DARWIN BLVD

**Lead Agency:** Managed by FDOT **Length:** 1.680 MI

Phase	Fund Source	2016/17	2017/18	2018/19	2019/20	2020/21	Total
ENV	SU	37,104	0	0	0	0	<b>37,104</b>
ENV	SA	147,896	0	0	0	0	<b>147,896</b>
ROW	SU	36,375	177,000	45,451	0	0	<b>258,826</b>
ROW	SA	36,375	0	0	0	0	<b>36,375</b>
ROW	TRIP	0	0	45,451	0	0	<b>45,451</b>
<b>Total</b>		<b>257,750</b>	<b>177,000</b>	<b>90,902</b>	<b>0</b>	<b>0</b>	<b>525,652</b>

**Prior Year Cost:** 2,596,870  
**Future Year Cost:** 0  
**Total Project Cost:** 3,122,522  
**LRTP:** Page 6-5



**PORT ST. LUCIE BOULEVARD**

**4317523**

**Non-SIS**

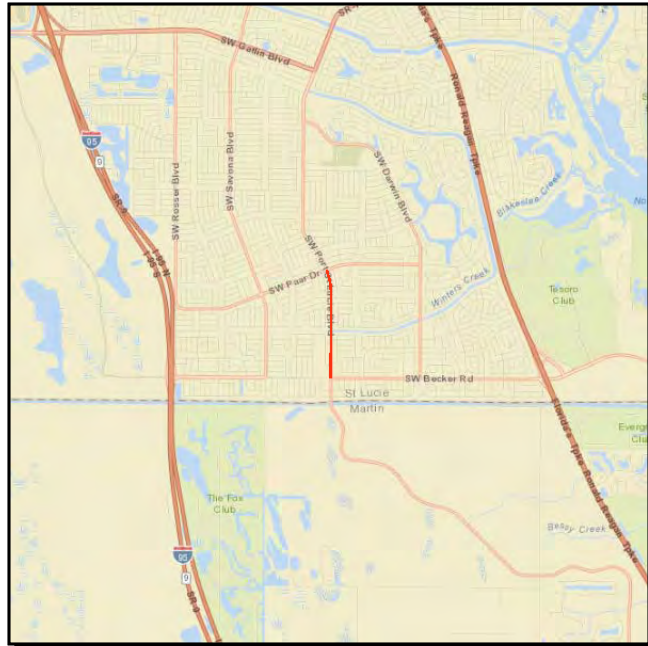

**Project Description:** WIDEN 2-4 LANES AND ADD BICYCLE LANES AND SIDEWALKS

**Work Summary:** ADD LANES & RECONSTRUCT **From:** BECKER ROAD

**To:** PAAR DRIVE

**Lead Agency:** Managed by FDOT **Length:** 1.119

Phase	Fund Source	2016/17	2017/18	2018/19	2019/20	2020/21	Total
PE	SU	0	0	0	0	2,010,000	2,010,000
<b>Total</b>		<b>0</b>	<b>0</b>	<b>0</b>	<b>0</b>	<b>2,010,000</b>	<b>2,010,000</b>

**Prior Year Cost:** 0  
**Future Year Cost:** 0  
**Total Project Cost:** 2,010,000  
**LRTP:** Page 7-1



**PORT ST. LUCIE BOULEVARD**

**4385441**

**Non-SIS**



**Project Description:** WIDEN 2-4 LANES AND ADD BICYCLE LANES AND SIDEWALKS

**Work Summary:** FUNDING ACTION      **From:** PAAR DRIVE  
**To:** DARWIN BLVD

**Lead Agency:** Managed by FDOT      **Length:** 1.685 mi

Phase	Fund Source	2016/17	2017/18	2018/19	2019/20	2020/21	Total
CST	SA	0	0	0	2,144,514	0	2,144,514
<b>Total</b>		<b>0</b>	<b>0</b>	<b>0</b>	<b>2,144,514</b>	<b>0</b>	<b>2,144,514</b>

**Prior Year Cost:** 0  
**Future Year Cost:** 0  
**Total Project Cost:** 2,144,514  
**LRTP:** Page 7-1



**SELVITZ ROAD**

**4352631**

**Non-SIS**

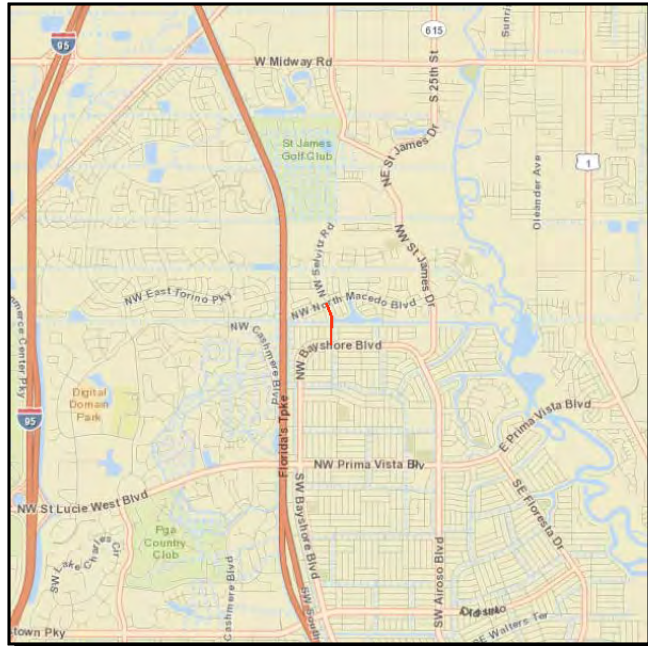

**Project Description:** ADD SIDEWALKS ON SELVITZ ROAD FROM BAYSHORE BLVD TO NORTH MACEDO BLVD.

**Work Summary:** SIDEWALK **From:** Bayshore Blvd.  
**To:** North Macedo Blvd.

**Lead Agency:** CITY OF PORT ST LUCIE **Length:** .420 MI

Phase	Fund Source	2016/17	2017/18	2018/19	2019/20	2020/21	Total
CST	SA	5,279	0	0	0	0	5,279
CST	LFP	58,265	0	0	0	0	58,265
CST	TALU	338,705	0	0	0	0	338,705
<b>Total</b>		<b>402,249</b>	<b>0</b>	<b>0</b>	<b>0</b>	<b>0</b>	<b>402,249</b>

**Prior Year Cost:** 5,000  
**Future Year Cost:** 0  
**Total Project Cost:** 407,249  
**LRTP:** Page 6-2

**SR-5/US-1**

**4385461**

**SIS**

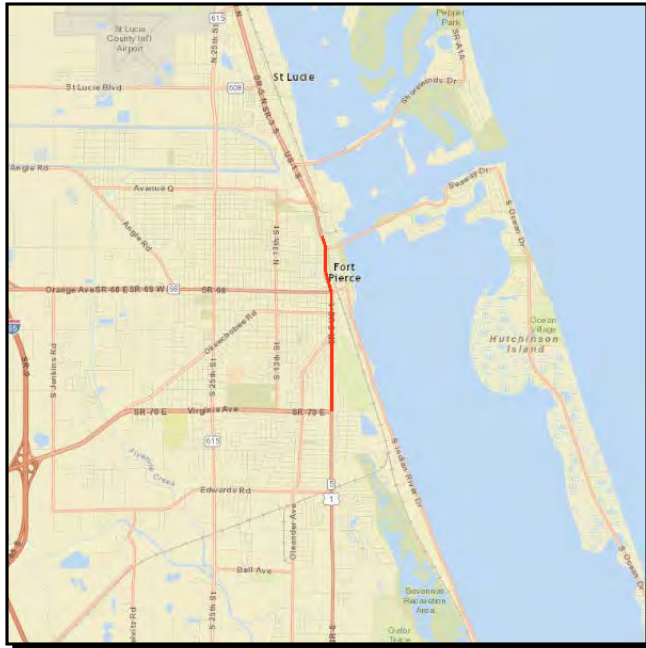

**Project Description:** OPERATE & MAINTAIN ADAPTIVE INTERSECTION CONTROL AT 12 INTERSECTIONS ALONG SR-5/US-1

**Work Summary:** ATMS - ARTERIAL TRAFFIC MGMT **From:** VIRGINIA AVENUE

**To:** AVENUE H

**Lead Agency:** Managed by FDOT **Length:** 2.195

Phase	Fund Source	2016/17	2017/18	2018/19	2019/20	2020/21	Total
CST	DIH	30,320	0	0	0	0	<b>30,320</b>
CST	DITS	1,309,535	0	0	0	0	<b>1,309,535</b>
RRU	DITS	7,000	0	0	0	0	<b>7,000</b>
<b>Total</b>		<b>1,346,855</b>	<b>0</b>	<b>0</b>	<b>0</b>	<b>0</b>	<b>1,346,855</b>

**Prior Year Cost:** 210,371  
**Future Year Cost:** 0  
**Total Project Cost:** 1,557,226  
**LRTP:** Page 7-1

**SR-713/KINGS HWY**

**4383791**

**Non-SIS**



**Project Description:** WIDEN 2-4 LANES AND ADD BICYCLE LANES AND SIDEWALKS

**Work Summary:** ADD LANES & RECONSTRUCT **From:** SR-9/I-95 OVERPASS

**To:** ST. LUCIE BOULEVARD

**Lead Agency:** Managed by FDOT **Length:** 1.640

Phase	Fund Source	2016/17	2017/18	2018/19	2019/20	2020/21	Total
PE	DS	0	2,000,000	0	0	0	2,000,000
PE	DIH	0	10,000	0	0	0	10,000
<b>Total</b>		<b>0</b>	<b>2,010,000</b>	<b>0</b>	<b>0</b>	<b>0</b>	<b>2,010,000</b>

**Prior Year Cost:** 0  
**Future Year Cost:** 0  
**Total Project Cost:** 2,010,000  
**LRTP:** Page 6-5

**ST. LUCIE COUNTY ATMS**

**4352451**

**SIS**

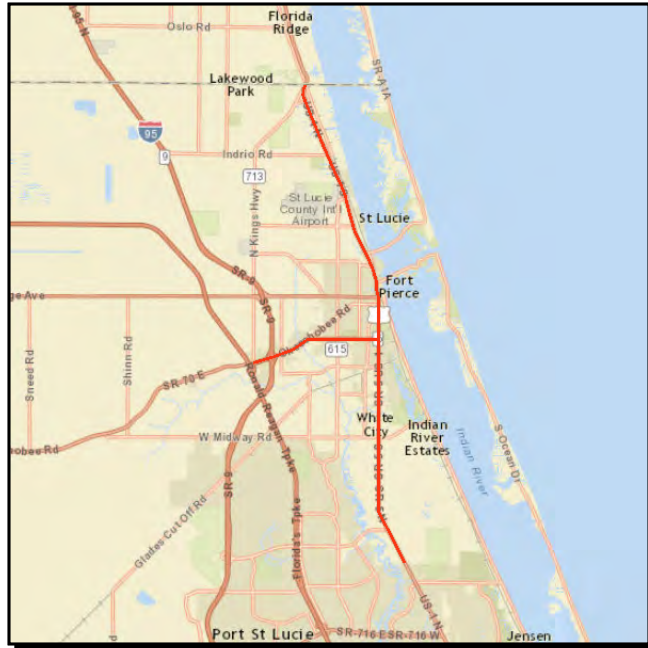

**Project Description:** ATMS - ARTERIAL TRAFFIC MANAGEMENT ON US-1 FROM SAVANA CLUB BLVD. TO KINGS HWY; SR-70 FROM KINGS HWY TO SR-5/US-1

**Work Summary:** ATMS - ARTERIAL TRAFFIC MGMT **From:** SAVANA CLUB BLVD, KINGS HWY

**To:** KINGS HWY, US-1

**Lead Agency:** Managed by FDOT **Length:** 21.767

Phase	Fund Source	2016/17	2017/18	2018/19	2019/20	2020/21	Total
ENV	DDR	0	0	0	0	8,000	<b>8,000</b>
DSB	DDR	0	0	0	0	4,724,726	<b>4,724,726</b>
DSB	DS	0	0	0	0	5,550,000	<b>5,550,000</b>
DSB	DIH	0	0	0	0	56,900	<b>56,900</b>
<b>Total</b>		<b>0</b>	<b>0</b>	<b>0</b>	<b>0</b>	<b>10,339,626</b>	<b>10,339,626</b>

**Prior Year Cost:** 156,037  
**Future Year Cost:** 0  
**Total Project Cost:** 10,495,663  
**LRTP:** Page 6-2





**US HIGHWAY 1**

**4287281**

**Non-SIS**

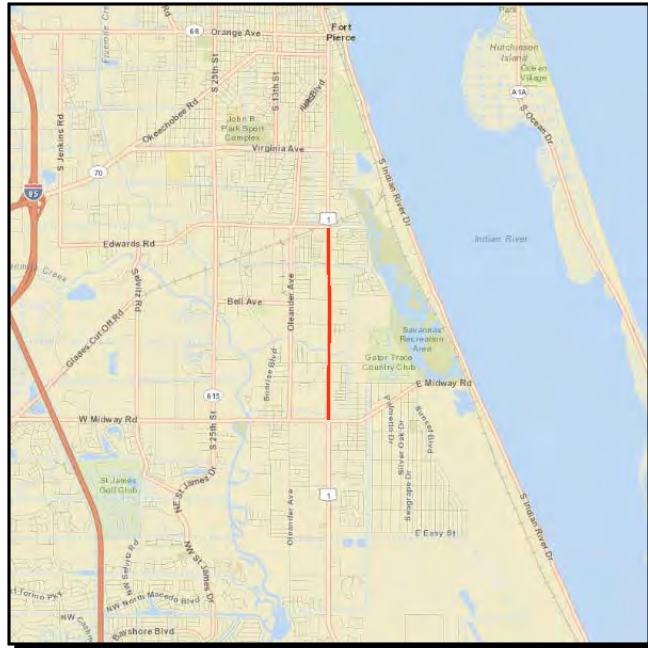

**Project Description:** Resurfacing of road and construction of sidewalks to fill sidewalk gaps

**Work Summary:** SIDEWALK  
**From:** MIDWAY ROAD  
**To:** EDWARDS ROAD

**Lead Agency:** FDOT  
**Length:** 2.310 mi

Phase	Fund Source	2016/17	2017/18	2018/19	2019/20	2020/21	Total
CST	SA	0	1,125,417	0	0	0	1,125,417
CST	DIH	0	31,488	0	0	0	31,488
CST	NHRE	0	2,490,930	0	0	0	2,490,930
CST	DDR	0	3,362,606	0	0	0	3,362,606
INC	DDR	0	0	75,000	0	0	75,000
<b>Total</b>		<b>0</b>	<b>7,010,441</b>	<b>75,000</b>	<b>0</b>	<b>0</b>	<b>7,085,441</b>

**Prior Year Cost:** 941,914  
**Future Year Cost:** 0  
**Total Project Cost:** 8,027,355  
**LRTP:** Page 6-2

**US-1 @ VIRGINIA AVENUE**

**4368681**

**SIS**

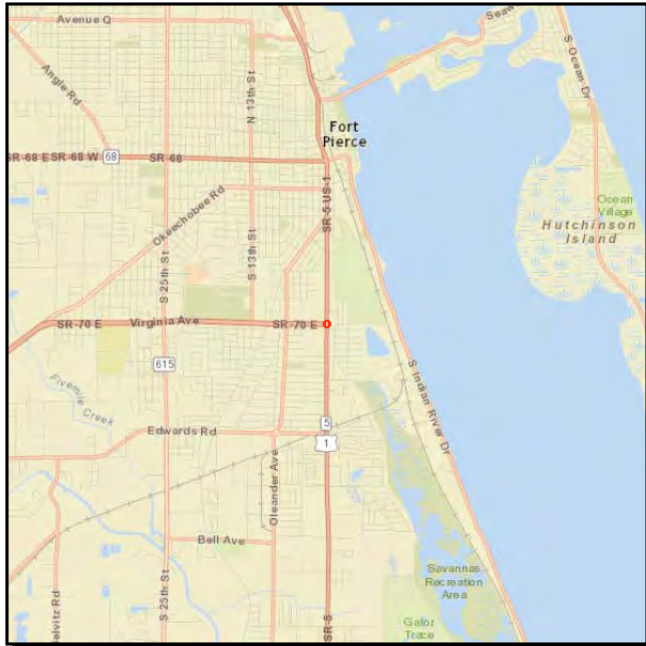

**Project Description:** ADD SOUTH BOUND RIGHT TURN LANE

**Work Summary:** ADD RIGHT TURN LANE(S)      **From:** Intersection

**To:** Intersection

**Lead Agency:** Managed by FDOT      **Length:** .050

Phase	Fund Source	2016/17	2017/18	2018/19	2019/20	2020/21	Total
PE	DDR	250,000	0	0	0	0	<b>250,000</b>
PE	DIH	5,000	0	0	0	0	<b>5,000</b>
ROW	SU	0	136,215	0	20,867	0	<b>157,082</b>
ROW	DS	0	0	0	1,125,144	0	<b>1,125,144</b>
CST	SU	0	0	0	817,471	0	<b>817,471</b>
<b>Total</b>		<b>255,000</b>	<b>136,215</b>	<b>0</b>	<b>1,963,482</b>	<b>0</b>	<b>2,354,697</b>

**Prior Year Cost:** 0  
**Future Year Cost:** 0  
**Total Project Cost:** 2,354,697  
**LRTP:** Page 6-2

**25 STREET / SR-615**

**4323261**

**Non-SIS**

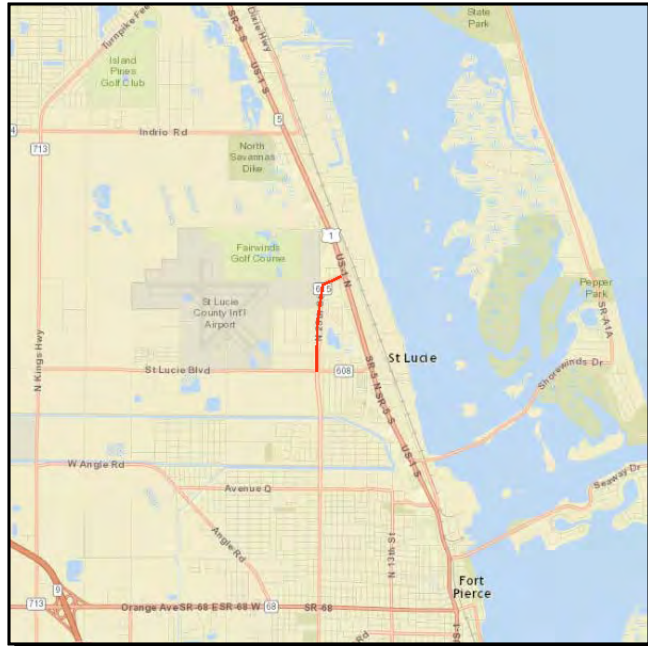

**Project Description:** Resurfacing North 25th Street from CR 608/St. Lucie Blvd. to SR 5/US-1 and addition of sidewalk from Industrial Ave. 3 to US-1

**Work Summary:** **From:** ST LUCIE BOULEVARD  
**To:** US 1

**Lead Agency:** Managed by FDOT **Length:** 1.152 MI

Phase	Fund Source	2016/17	2017/18	2018/19	2019/20	2020/21	Total
CST	DIH	30,750	0	0	0	0	30,750
CST	DDR	2,394,169	0	0	0	0	2,394,169
<b>Total</b>		<b>2,424,919</b>	<b>0</b>	<b>0</b>	<b>0</b>	<b>0</b>	<b>2,424,919</b>

**Prior Year Cost:** 302,315  
**Future Year Cost:** 0  
**Total Project Cost:** 2,727,234  
**LRTP:** Page 6-2



**Section C 2 - Aviation Projects**

---

**TREASURE COAST INTERNATIONAL AIRPORT**

**4297131**

**Non-SIS**

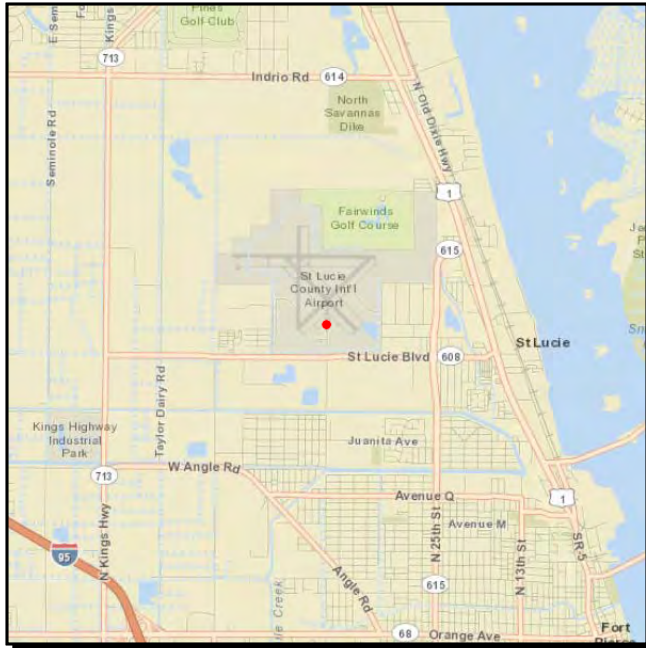

**Project Description:** PREPARATION OF ENVIRONMENTAL IMPACT STATEMENT (EIS) OF NORTH INDUSTRIAL PARK

**Work Summary:** AVIATION ENVIRONMENTAL **From:**

**To:**

**Lead Agency:** ST LUCIE COUNTY

Phase	Fund Source	2016/17	2017/18	2018/19	2019/20	2020/21	Total
CAP	DPTO	200,000	0	0	0	0	<b>200,000</b>
CAP	LF	80,000	0	0	0	0	<b>80,000</b>
<b>Total</b>		<b>280,000</b>	<b>0</b>	<b>0</b>	<b>0</b>	<b>0</b>	<b>280,000</b>

**Prior Year Cost:** 0  
**Future Year Cost:** 0  
**Total Project Cost:** 280,000  
**LRTP:** Page 7-1

**TREASURE COAST INTERNATIONAL AIRPORT**

**4297141**

**Non-SIS**

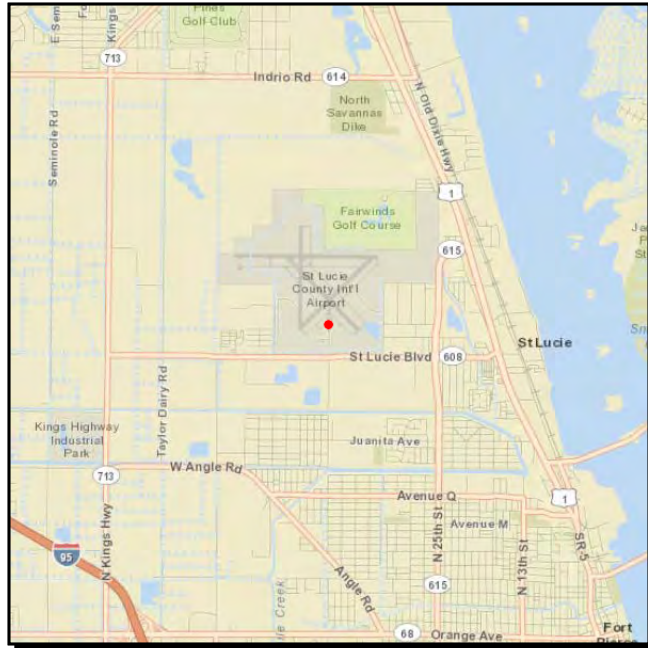

**Project Description:** STORM WATER POLLUTION PREVENTION PLAN UPDATES

**Work Summary:** AVIATION PRESERVATION **From:**

**To:**

**Lead Agency:** ST LUCIE COUNTY

Phase	Fund Source	2016/17	2017/18	2018/19	2019/20	2020/21	Total
CAP	DPTO	120,000	0	0	0	0	120,000
CAP	LF	30,000	0	0	0	0	30,000
<b>Total</b>		<b>150,000</b>	<b>0</b>	<b>0</b>	<b>0</b>	<b>0</b>	<b>150,000</b>

**Prior Year Cost:** 0  
**Future Year Cost:** 0  
**Total Project Cost:** 150,000  
**LRTP:** Page 7-1

**TREASURE COAST INTERNATIONAL AIRPORT**

**4310001**

**Non-SIS**

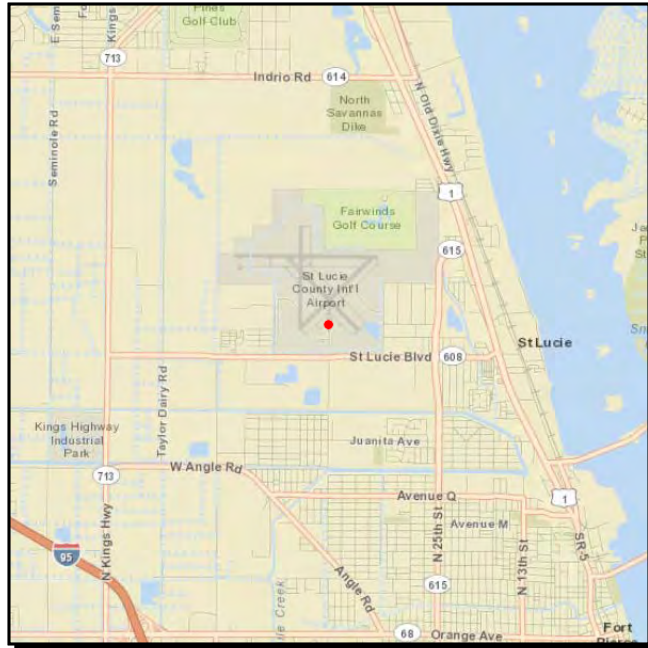

**Project Description:** INSTALLATION OF DRAINAGE & EROSION CONTROL IMPROVEMENTS

**Work Summary:** AVIATION PRESERVATION **From:**

**To:**

**Lead Agency:** ST LUCIE COUNTY

Phase	Fund Source	2016/17	2017/18	2018/19	2019/20	2020/21	Total
CAP	DPTO	320,000	0	0	0	0	<b>320,000</b>
CAP	LF	80,000	0	0	0	0	<b>80,000</b>
<b>Total</b>		<b>400,000</b>	<b>0</b>	<b>0</b>	<b>0</b>	<b>0</b>	<b>400,000</b>

**Prior Year Cost:** 0  
**Future Year Cost:** 0  
**Total Project Cost:** 400,000  
**LRTP:** Page 7-1

**TREASURE COAST INTERNATIONAL AIRPORT**

**4310281**

**Non-SIS**

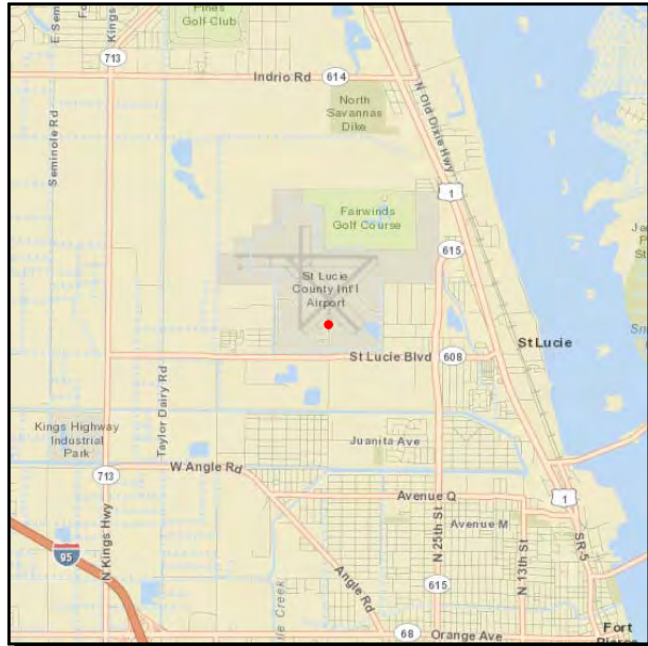

**Project Description:** CONSTRUCT SURFACE/TERMINAL PARKING

**Work Summary:** AVIATION **From:**  
**To:**

**Lead Agency:** ST LUCIE COUNTY

Phase	Fund Source	2016/17	2017/18	2018/19	2019/20	2020/21	Total
CAP	DDR	591,200	0	0	0	0	<b>591,200</b>
CAP	LF	147,800	0	0	0	0	<b>147,800</b>
<b>Total</b>		<b>739,000</b>	<b>0</b>	<b>0</b>	<b>0</b>	<b>0</b>	<b>739,000</b>

**Prior Year Cost:** 0  
**Future Year Cost:** 0  
**Total Project Cost:** 739,000  
**LRTP:** Page 7-1

**TREASURE COAST INTERNATIONAL AIRPORT**

**4310721**

**Non-SIS**

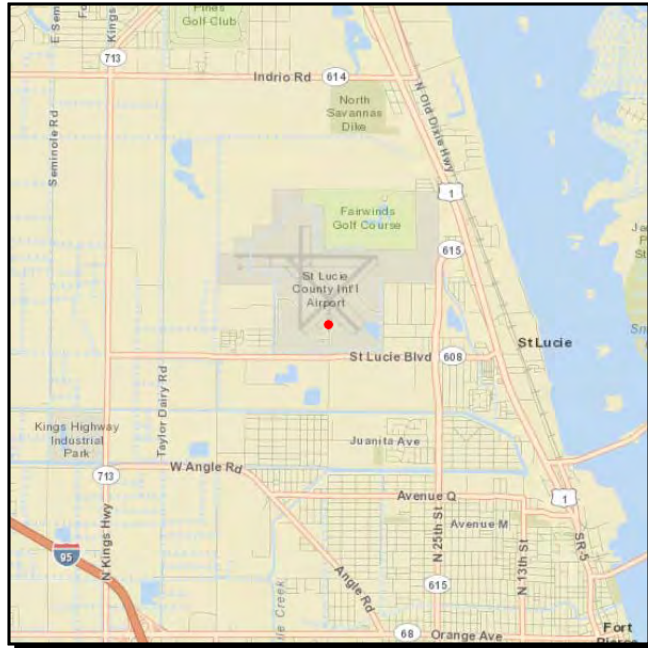

**Project Description:** INSTALLATION OF AIRPORT NOISE OPS MONITORING SYS (NOMS)

**Work Summary:** AVIATION ENVIRONMENTAL **From:**

**To:**

**Lead Agency:** ST LUCIE COUNTY

**Length:** .000

Phase	Fund Source	2016/17	2017/18	2018/19	2019/20	2020/21	Total
CAP	DPTO	312,301	0	0	0	0	<b>312,301</b>
CAP	DDR	327,699	0	0	0	0	<b>327,699</b>
CAP	LF	160,000	0	0	0	0	<b>160,000</b>
<b>Total</b>		<b>800,000</b>	<b>0</b>	<b>0</b>	<b>0</b>	<b>0</b>	<b>800,000</b>

**Prior Year Cost:** 0  
**Future Year Cost:** 0  
**Total Project Cost:** 800,000  
**LRTP:** Page 7-1

**TREASURE COAST INTERNATIONAL AIRPORT**

**4315181**

**Non-SIS**

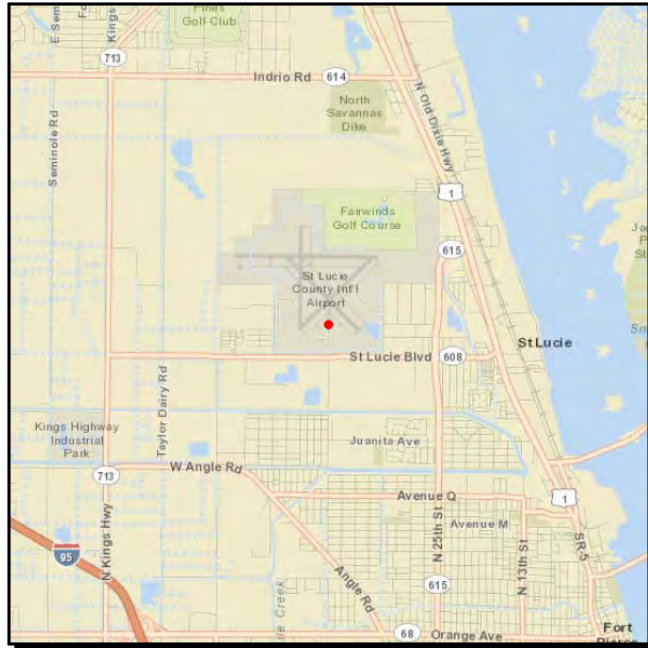

**Project Description:** DESIGN & CONSTRUCT SEGMENTED CIRCLE

**Work Summary:** AVIATION PRESERVATION **From:**

**To:**

**Lead Agency:** ST LUCIE COUNTY

Phase	Fund Source	2016/17	2017/18	2018/19	2019/20	2020/21	Total
CAP	DPTO	36,000	0	0	0	0	36,000
CAP	LF	9,000	0	0	0	0	9,000
<b>Total</b>		<b>45,000</b>	<b>0</b>	<b>0</b>	<b>0</b>	<b>0</b>	<b>45,000</b>

**Prior Year Cost:** 0  
**Future Year Cost:** 0  
**Total Project Cost:** 45,000  
**LRTP:** Page 7-1



**TREASURE COAST INTERNATIONAL AIRPORT**

**4331451**

**Non-SIS**

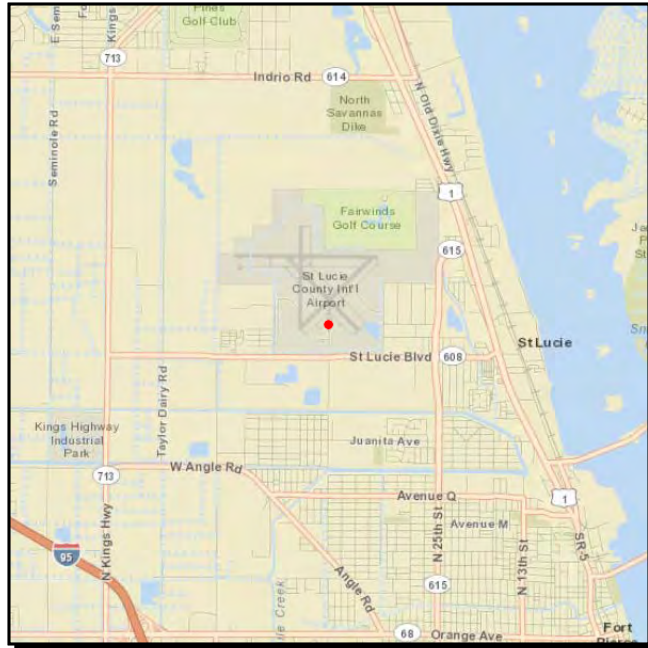

**Project Description:** STRENGTHEN RUNWAY 10R/28L

**Work Summary:** AVIATION PRESERVATION **From:**

**To:**

**Lead Agency:** ST LUCIE COUNTY

Phase	Fund Source	2016/17	2017/18	2018/19	2019/20	2020/21	Total
CAP	DPTO	0	0	0	183,986	0	<b>183,986</b>
CAP	FAA	0	0	0	3,311,754	0	<b>3,311,754</b>
CAP	LF	0	0	0	183,986	0	<b>183,986</b>
<b>Total</b>		<b>0</b>	<b>0</b>	<b>0</b>	<b>3,679,726</b>	<b>0</b>	<b>3,679,726</b>

**Prior Year Cost:** 0  
**Future Year Cost:** 0  
**Total Project Cost:** 3,679,726  
**LRTP:** Page 7-1



**TREASURE COAST INTERNATIONAL AIRPORT**

**4331471**

**Non-SIS**

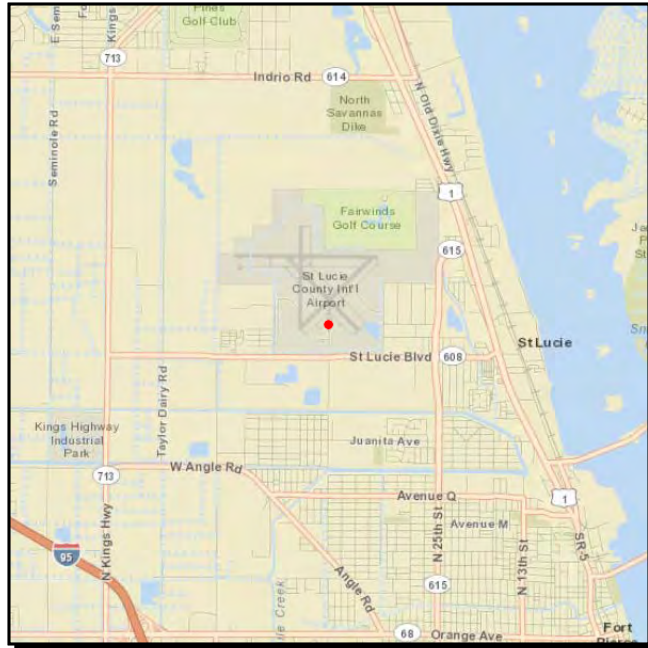

**Project Description:** INSTALL SEGMENTED CIRCLE RUNWAY 10L/28R

**Work Summary:** AVIATION PRESERVATION **From:**

**To:**

**Lead Agency:** ST LUCIE COUNTY

Phase	Fund Source	2016/17	2017/18	2018/19	2019/20	2020/21	Total
CAP	DPTO	0	60,000	0	0	0	60,000
CAP	LF	0	15,000	0	0	0	15,000
<b>Total</b>		<b>0</b>	<b>75,000</b>	<b>0</b>	<b>0</b>	<b>0</b>	<b>75,000</b>

**Prior Year Cost:** 0  
**Future Year Cost:** 0  
**Total Project Cost:** 75,000  
**LRTP:** Page 7-1

**TREASURE COAST INTERNATIONAL AIRPORT**

**4346341**

**Non-SIS**

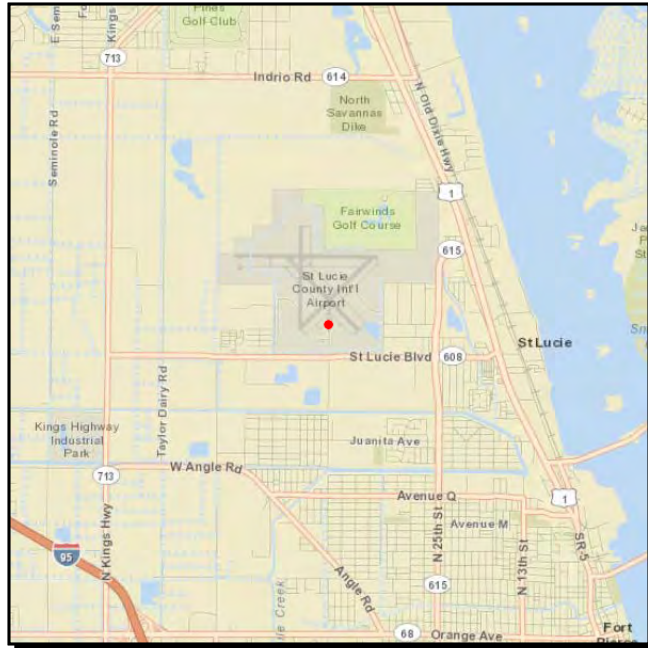

**Project Description:** INSTALL SECURITY PERIMETER FENCING & ACCESS CONTROL

**Work Summary:** AVIATION PRESERVATION **From:**

**To:**

**Lead Agency:** ST LUCIE COUNTY

Phase	Fund Source	2016/17	2017/18	2018/19	2019/20	2020/21	Total
CAP	DPTO	0	0	237,462	0	0	<b>237,462</b>
CAP	DDR	0	0	278,538	0	0	<b>278,538</b>
CAP	LF	0	0	129,000	0	0	<b>129,000</b>
<b>Total</b>		<b>0</b>	<b>0</b>	<b>645,000</b>	<b>0</b>	<b>0</b>	<b>645,000</b>

**Prior Year Cost:** 0  
**Future Year Cost:** 0  
**Total Project Cost:** 645,000  
**LRTP:** Page 7-1

**TREASURE COAST INTERNATIONAL AIRPORT**

**4346351**

**Non-SIS**

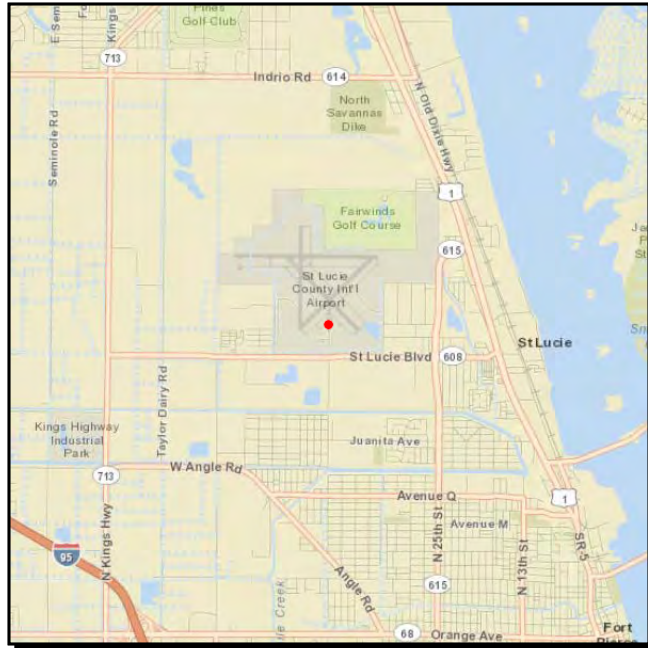

**Project Description:** INSTALL AIRFIELD SIGNAGE & LIGHTING

**Work Summary:** AVIATION PRESERVATION **From:**

**To:**

**Lead Agency:** ST LUCIE COUNTY

Phase	Fund Source	2016/17	2017/18	2018/19	2019/20	2020/21	Total
CAP	DPTO	0	0	90,000	0	0	<b>90,000</b>
CAP	FAA	0	0	1,620,000	0	0	<b>1,620,000</b>
CAP	LF	0	0	90,000	0	0	<b>90,000</b>
<b>Total</b>		<b>0</b>	<b>0</b>	<b>1,800,000</b>	<b>0</b>	<b>0</b>	<b>1,800,000</b>

**Prior Year Cost:** 0  
**Future Year Cost:** 0  
**Total Project Cost:** 1,800,000  
**LRTP:** Page 7-1

**TREASURE COAST INTERNATIONAL AIRPORT**

**4363921**

**Non-SIS**

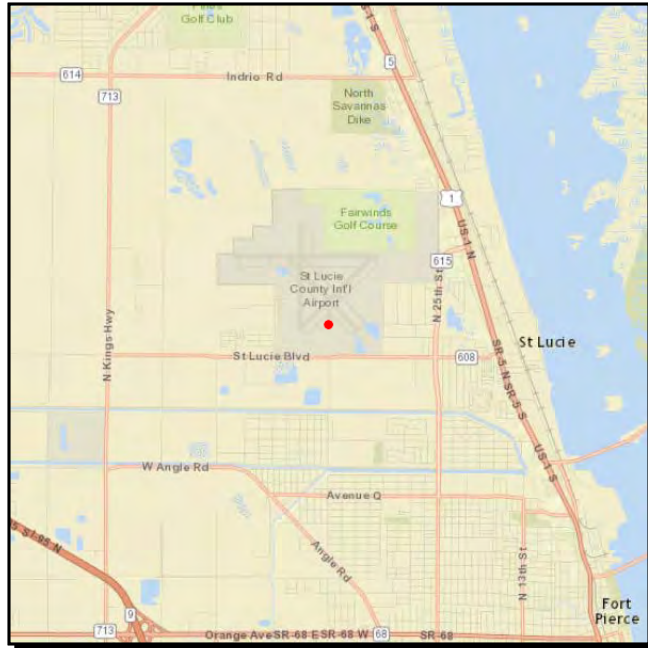

**Project Description:** PREPARATION OF ENVIRONMENTAL ASSESSMENT NOISE STUDY

**Work Summary:** AVIATION ENVIRONMENTAL **From:**

**To:**

**Lead Agency:** ST LUCIE COUNTY

Phase	Fund Source	2016/17	2017/18	2018/19	2019/20	2020/21	Total
CAP	DPTO	0	37,500	0	0	0	<b>37,500</b>
CAP	FAA	0	675,000	0	0	0	<b>675,000</b>
CAP	LF	0	37,500	0	0	0	<b>37,500</b>
<b>Total</b>		<b>0</b>	<b>750,000</b>	<b>0</b>	<b>0</b>	<b>0</b>	<b>750,000</b>

**Prior Year Cost:** 0  
**Future Year Cost:** 0  
**Total Project Cost:** 750,000  
**LRTP:** Page 7-1

---

**Section C 3 - Transit Operations, Equipment, and Facilities**

---

**BLOCK GRANT**

**4071873**

**Non-SIS**



**Project Description:** TRANSIT OPERATING ASSISTANCE AND ADMINISTRATIVE ASSISTANCE

**Work Summary:** OPERATING/ADMIN. ASSISTANCE **From:**

**To:**

**Lead Agency:** MANAGED BY ST. LUCIE COUNTY **Length:** .000

Phase	Fund Source	2016/17	2017/18	2018/19	2019/20	2020/21	Total
OPS	DPTO	0	0	0	598,714	616,675	1,215,389
OPS	LF	0	0	0	598,714	616,675	1,215,389
<b>Total</b>		<b>0</b>	<b>0</b>	<b>0</b>	<b>1,197,428</b>	<b>1,233,350</b>	<b>2,430,778</b>

**Prior Year Cost:** 0  
**Future Year Cost:** 0  
**Total Project Cost:** 2,430,778  
**LRTP:** Page 7-1

**BLOCK GRANT**

**4071872**

**Non-SIS**

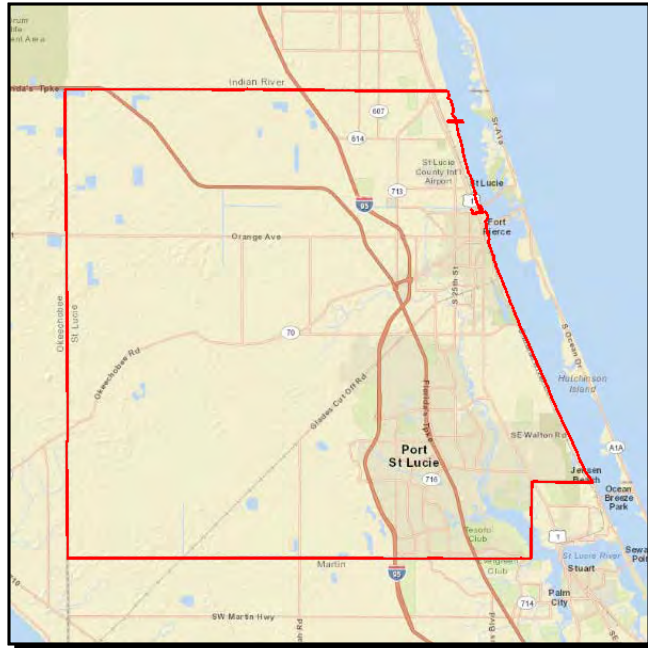

**Project Description:** TRANSIT OPERATING ASSISTANCE AND ADMINISTRATIVE ASSISTANCE

**Work Summary:** TRANSPORTATION PLANNING **From:**

**To:**

**Lead Agency:** FDOT

Phase	Fund Source	2016/17	2017/18	2018/19	2019/20	2020/21	Total
OPS	DPTO	538,071	551,981	0	0	0	1,090,052
OPS	LF	538,071	551,981	570,204	0	0	1,660,256
OPS	DDR	0	0	570,204	0	0	570,204
<b>Total</b>		<b>1,076,142</b>	<b>1,103,962</b>	<b>1,140,408</b>	<b>0</b>	<b>0</b>	<b>3,320,512</b>

**Prior Year Cost:** 2,131,108

**Future Year Cost:** 0

**Total Project Cost:** 5,451,620

**LRTP:** Page 7-1



**CITY OF FT. PIERCE JPA SIGNAL MAINTENANCE & OPERATIONS**

**4278057**

**Non-SIS**

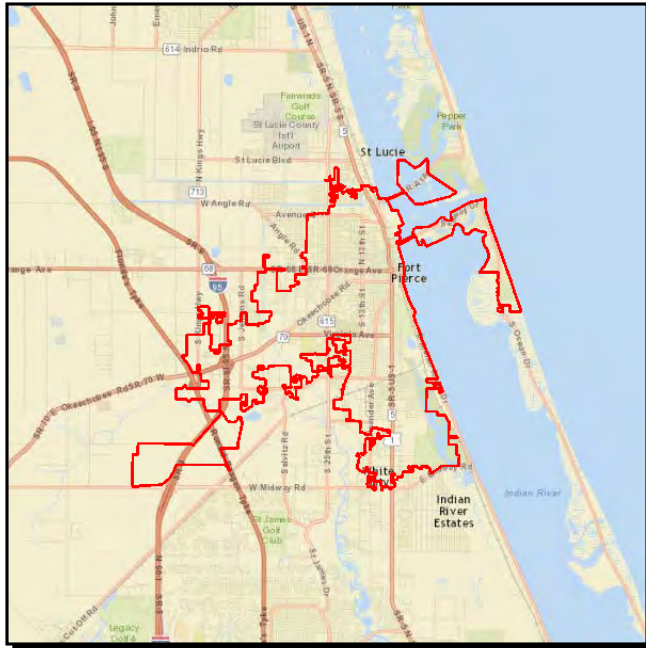

**Project Description:** OPERATION AND MAINTENANCE OF THE TRAFFIC CONTROL SYSTEM

**Work Summary:** TRAFFIC SIGNALS **From:**  
**To:**

**Lead Agency:** MANAGED BY CITY OF FORT PIERCE **Length:** .000

Phase	Fund Source	2016/17	2017/18	2018/19	2019/20	2020/21	Total
OPS	DITS	89,776	92,020	94,321	96,679	0	<b>372,796</b>
OPS	DDR	161,698	166,999	172,468	178,114	0	<b>679,279</b>
<b>Total</b>		<b>251,474</b>	<b>259,019</b>	<b>266,789</b>	<b>274,793</b>	<b>0</b>	<b>1,052,075</b>

**Prior Year Cost:** 139,361  
**Future Year Cost:** 0  
**Total Project Cost:** 1,191,436  
**LRTP:** Page 7-1

**CITY OF FT. PIERCE JPA SIGNAL MAINTENANCE & OPERATIONS**

**4379751**

**Non-SIS**

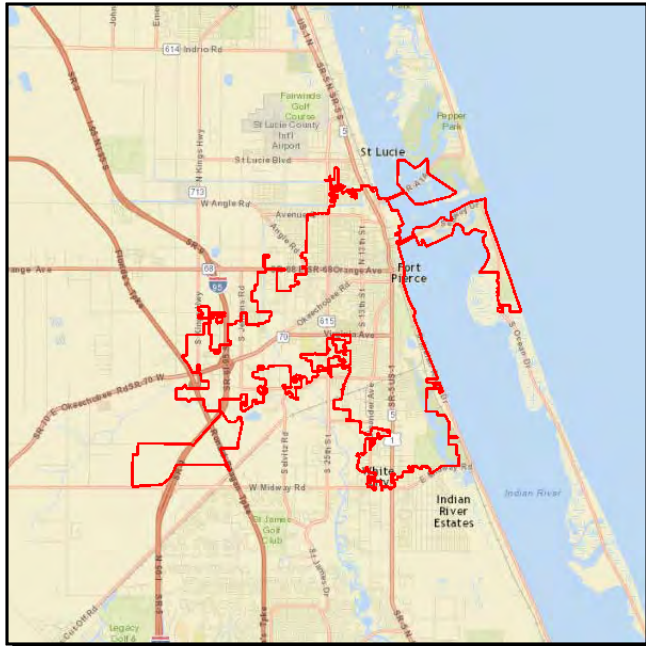

**Project Description:** OPERATION AND MAINTENANCE OF THE TRAFFIC CONTROL SYSTEM AND INTERSECTIONS ON THE STATE HIGHWAY SYSTEM

**Work Summary:** TRAFFIC SIGNALS **From:**  
**To:**

**Lead Agency:** MANAGED BY CITY OF FORT PIERCE **Length:** .000

Phase	Fund Source	2016/17	2017/18	2018/19	2019/20	2020/21	Total
OPS	DITS	0	0	0	0	99,096	<b>99,096</b>
OPS	DDR	0	0	0	0	183,941	<b>183,941</b>
<b>Total</b>		<b>0</b>	<b>0</b>	<b>0</b>	<b>0</b>	<b>283,037</b>	<b>283,037</b>

**Prior Year Cost:** 0  
**Future Year Cost:** 0  
**Total Project Cost:** 283,037  
**LRTP:** Page 7-1

**CITY OF PORT ST. LUCIE JPA SIGNAL MAINTENANCE &**

**4278059**

**Non-SIS**

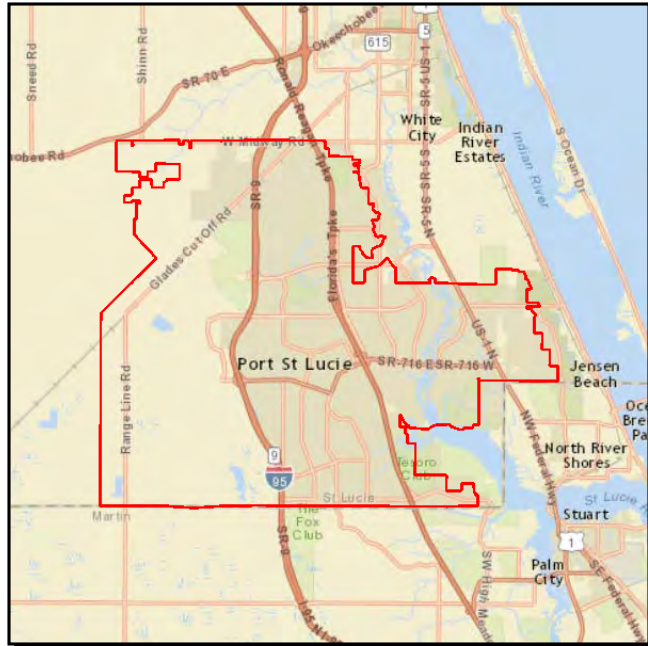

**Project Description:** OPERATION AND MAINTENANCE OF THE TRAFFIC CONTROL SYSTEM AND INTERSECTIONS ON THE STATE HIGHWAY SYSTEM

**Work Summary:** TRAFFIC SIGNALS **From:**

**To:**

**Lead Agency:** MANAGED BY CITY OF PORT ST. LUCIE **Length:** .000

Phase	Fund Source	2016/17	2017/18	2018/19	2019/20	2020/21	Total
OPS	DITS	71,400	73,185	75,015	76,890	0	<b>296,490</b>
OPS	DDR	89,963	93,301	96,465	99,735	0	<b>379,464</b>
<b>Total</b>		<b>161,363</b>	<b>166,486</b>	<b>171,480</b>	<b>176,625</b>	<b>0</b>	<b>675,954</b>

**Prior Year Cost:** 64,904  
**Future Year Cost:** 0  
**Total Project Cost:** 740,858  
**LRTP:** Page 7-1

**CITY OF PORT ST. LUCIE JPA SIGNAL MAINTENANCE &**

**4379771**

**Non-SIS**

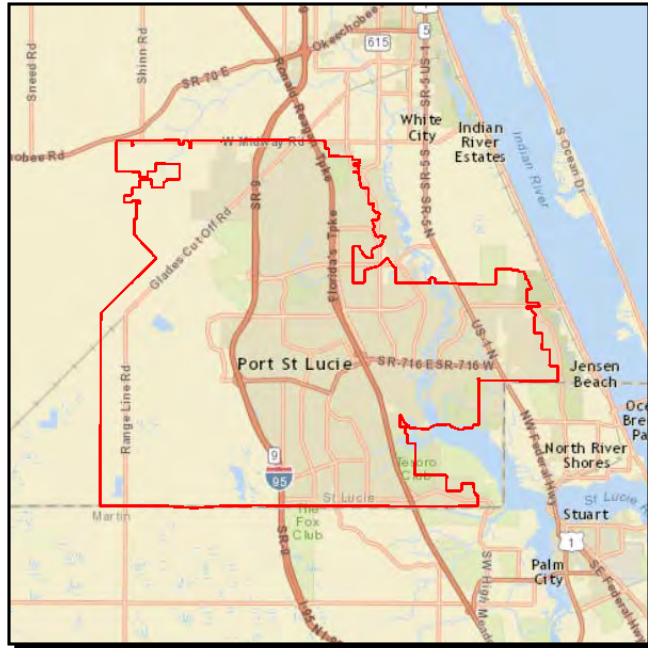

**Project Description:** OPERATION AND MAINTENANCE OF THE TRAFFIC CONTROL SYSTEM AND INTERSECTIONS ON THE STATE HIGHWAY SYSTEM

**Work Summary:** TRAFFIC SIGNALS **From:**  
**To:**

**Lead Agency:** MANAGED BY CITY OF PORT ST. LUCIE **Length:** .000

Phase	Fund Source	2016/17	2017/18	2018/19	2019/20	2020/21	Total
OPS	DITS	0	0	0	0	78,812	<b>78,812</b>
OPS	DDR	0	0	0	0	103,111	<b>103,111</b>
<b>Total</b>		<b>0</b>	<b>0</b>	<b>0</b>	<b>0</b>	<b>181,923</b>	<b>181,923</b>

**Prior Year Cost:** 0  
**Future Year Cost:** 0  
**Total Project Cost:** 181,923  
**LRTP:** Page 7-1

**PARK AND RIDE LOT (Jobs Express Terminal)**

**4226814**

**Non-SIS**

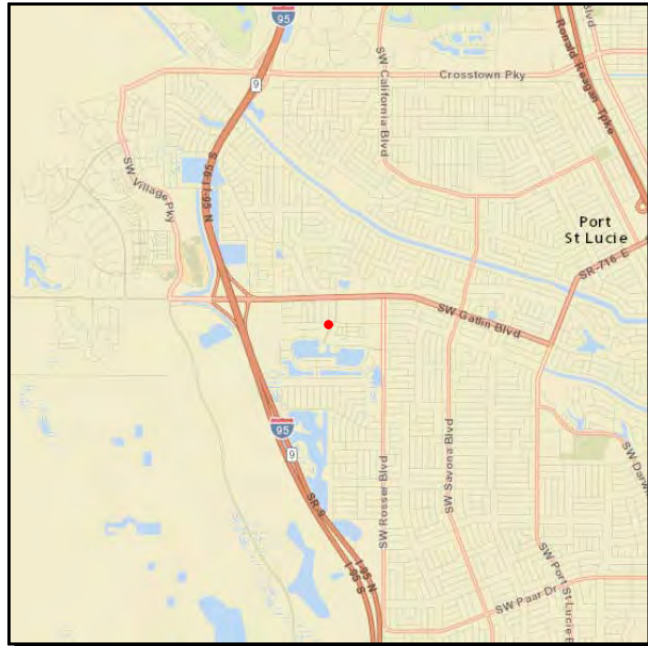

**Project Description:** Construction of Park & Ride Lot located on FPL and PSL owned land next to Home Depot on Gatlin Blvd.

**Work Summary:** PARK AND RIDE LOTS **From:**  
**To:**

**Lead Agency:** Managed by FDOT

Phase	Fund Source	2016/17	2017/18	2018/19	2019/20	2020/21	Total
ROW	DDR	0	0	0	133,000	0	<b>133,000</b>
ROW	DS	0	0	0	4,089,956	0	<b>4,089,956</b>
ROW	DIH	0	0	0	40,000	0	<b>40,000</b>
CST	DIH	0	0	0	0	141,055	<b>141,055</b>
CST	DDR	0	0	0	0	3,671,894	<b>3,671,894</b>
<b>Total</b>		<b>0</b>	<b>0</b>	<b>0</b>	<b>4,262,956</b>	<b>3,812,949</b>	<b>8,075,905</b>

**Prior Year Cost:** 578,333  
**Future Year Cost:** 0  
**Total Project Cost:** 8,654,238  
**LRTP:** Page 7-1

**SECTION 5307**

**4134941**

**Non-SIS**

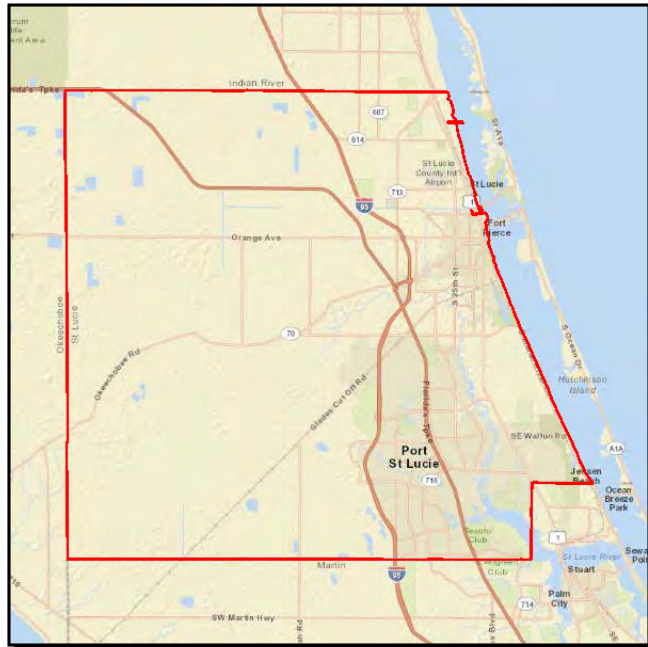

**Project Description:** CAPITAL AND OPERATION ASSISTANCE FOR FIXED ROUTE

**Work Summary:** CAPITAL FOR FIXED ROUTE **From:**

**To:**

**Lead Agency:** FDOT

Phase	Fund Source	2016/17	2017/18	2018/19	2019/20	2020/21	Total
OPS	FTA	2,200,000	2,200,000	2,200,000	2,200,000	2,200,000	<b>11,000,000</b>
CAP	FTA	494,000	494,000	494,000	494,000	494,000	<b>2,470,000</b>
<b>Total</b>		<b>2,694,000</b>	<b>2,694,000</b>	<b>2,694,000</b>	<b>2,694,000</b>	<b>2,694,000</b>	<b>13,470,000</b>

**Prior Year Cost:** 17,884,273

**Future Year Cost:** 0

**Total Project Cost:** 31,354,273

**LRTP:** Page 7-1



**SECTION 5311**

**4071852**

**Non-SIS**

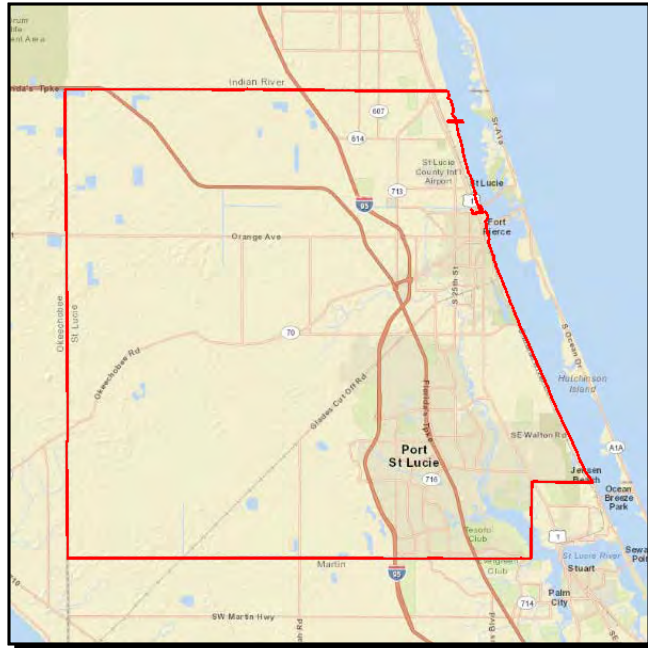

**Project Description:** SECTION 5311 SMALL URBAN/RURAL OPERATING/ADMIN ASSISTANCE

**Work Summary:** OPERATING/ADMIN. ASSISTANCE **From:**

**To:**

**Lead Agency:** FDOT

Phase	Fund Source	2016/17	2017/18	2018/19	2019/20	2020/21	Total
OPS	DU	50,980	60,547	63,465	0	0	174,992
OPS	LF	55,113	60,547	63,465	0	0	179,125
<b>Total</b>		<b>106,093</b>	<b>121,094</b>	<b>126,930</b>	<b>0</b>	<b>0</b>	<b>354,117</b>

**Prior Year Cost:** 210,714  
**Future Year Cost:** 0  
**Total Project Cost:** 564,831  
**LRTP:** Page 7-1



**SECTION 5311**

**4071853**

**Non-SIS**

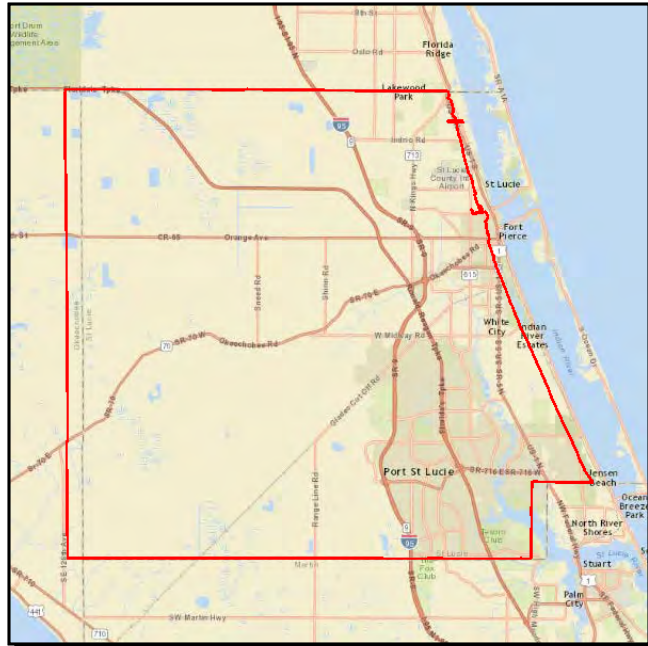

**Project Description:** SECTION 5311 SMALL URBAN/RURAL OPERATING/ADMIN

**Work Summary:** OPERATING/ADMIN. ASSISTANCE **From:**

**To:**

**Lead Agency:** MANAGED BY ST. LUCIE COUNTY **Length:** .000

Phase	Fund Source	2016/17	2017/18	2018/19	2019/20	2020/21	Total
OPS	DU	0	0	0	56,000	56,000	112,000
OPS	LF	0	0	0	56,000	56,000	112,000
<b>Total</b>		<b>0</b>	<b>0</b>	<b>0</b>	<b>112,000</b>	<b>112,000</b>	<b>224,000</b>

**Prior Year Cost:** 0  
**Future Year Cost:** 0  
**Total Project Cost:** 224,000  
**LRTP:** Page 7-1

**SECTION 5339**

**4345481**

**Non-SIS**

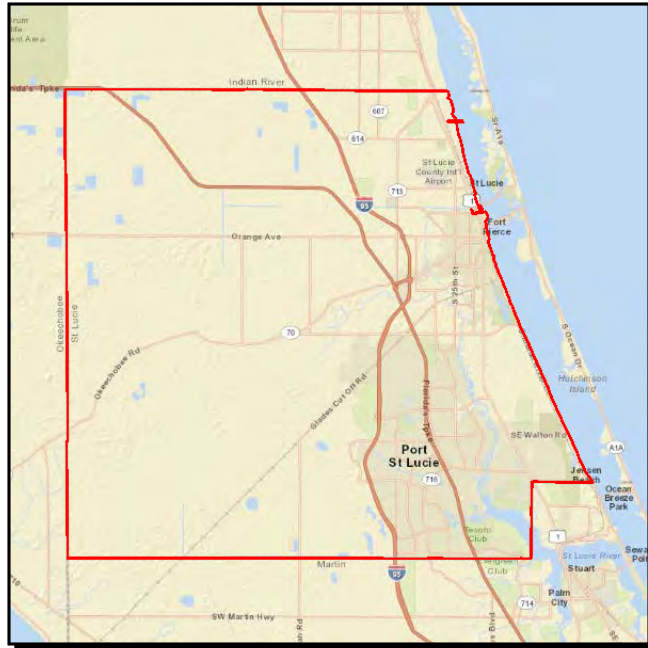

**Project Description:** ST. LUCIE CO. SECTION 5339 CAPITAL FOR BUS & BUS FACILITIES PROGRAM 16. CAPITAL FOR FIXED ROUTE

**Work Summary:** CAPITAL FOR FIXED ROUTE **From:**

**To:**

**Lead Agency:** ST LUCIE COUNTY **Length:** .000

Phase	Fund Source	2016/17	2017/18	2018/19	2019/20	2020/21	Total
CAP	FTA	197,400	197,400	197,400	197,400	197,400	<b>987,000</b>
<b>Total</b>		<b>197,400</b>	<b>197,400</b>	<b>197,400</b>	<b>197,400</b>	<b>197,400</b>	<b>987,000</b>

**Prior Year Cost:** 592,114  
**Future Year Cost:** 0  
**Total Project Cost:** 1,579,114  
**LRTP:** Page 7-1

**ST LUCIE COUNTY JPA SIGNAL MAINTENANCE & OPERATIONS ON**

**4278058**

**Non-SIS**



**Project Description:** OPERATION AND MAINTENANCE OF THE TRAFFIC CONTROL SYSTEM AND INTERSECTIONS ON THE STATE HIGHWAY SYSTEM

**Work Summary:** TRAFFIC SIGNALS **From:**  
**To:**

**Lead Agency:** MANAGED BY ST LUCIE COUNTY **Length:** .000

Phase	Fund Source	2016/17	2017/18	2018/19	2019/20	2020/21	Total
OPS	DITS	77,788	79,733	81,726	83,769	0	323,016
OPS	DDR	90,507	93,611	96,819	100,132	0	381,069
<b>Total</b>		<b>168,295</b>	<b>173,344</b>	<b>178,545</b>	<b>183,901</b>	<b>0</b>	<b>704,085</b>

**Prior Year Cost:** 120,384  
**Future Year Cost:** 0  
**Total Project Cost:** 824,469  
**LRTP:** Page 7-1

**ST LUCIE COUNTY JPA SIGNAL MAINTENANCE & OPERATIONS ON**

**4379761**

**Non-SIS**



**Project Description:** OPERATION AND MAINTENANCE OF THE TRAFFIC CONTROL SYSTEM AND INTERSECTIONS ON THE STATE HIGHWAY SYSTEM

**Work Summary:** TRAFFIC SIGNALS      **From:**  
**To:**

**Lead Agency:** MANAGED BY ST LUCIE COUNTY      **Length:** .000

Phase	Fund Source	2016/17	2017/18	2018/19	2019/20	2020/21	Total
OPS	DITS	0	0	0	0	85,863	<b>85,863</b>
OPS	DDR	0	0	0	0	103,555	<b>103,555</b>
<b>Total</b>		<b>0</b>	<b>0</b>	<b>0</b>	<b>0</b>	<b>189,418</b>	<b>189,418</b>

**Prior Year Cost:** 0  
**Future Year Cost:** 0  
**Total Project Cost:** 189,418  
**LRTP:** Page 7-1

---

**Section C 4 - Miscellaneous Projects**

---

**FEC/AMTRAK PASSENGER SERVICE**

**4301261**

**Non-SIS**

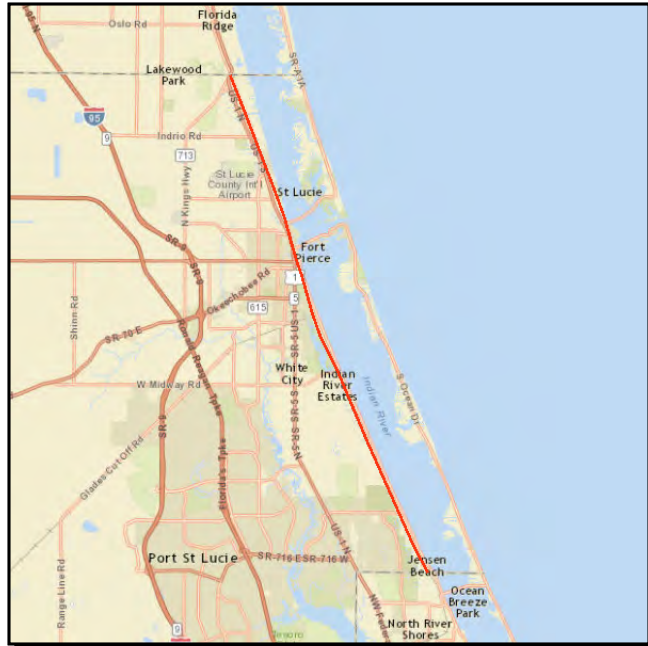

**Project Description:** FUNDING FOR OPERATIONAL IMPROVEMENTS

**Work Summary:** RAIL CAPACITY PROJECT **From:**

**To:**

**Lead Agency:** FDOT

Phase	Fund Source	2016/17	2017/18	2018/19	2019/20	2020/21	Total
OPS	GMR	25,000,000	0	0	0	0	25,000,000
<b>Total</b>		<b>25,000,000</b>	<b>0</b>	<b>0</b>	<b>0</b>	<b>0</b>	<b>25,000,000</b>

**Prior Year Cost:** 0  
**Future Year Cost:** 0  
**Total Project Cost:** 25,000,000  
**LRTP:** Page 7-1

**KINGS HWY / SR-713**

**4380411**

**Non-SIS**

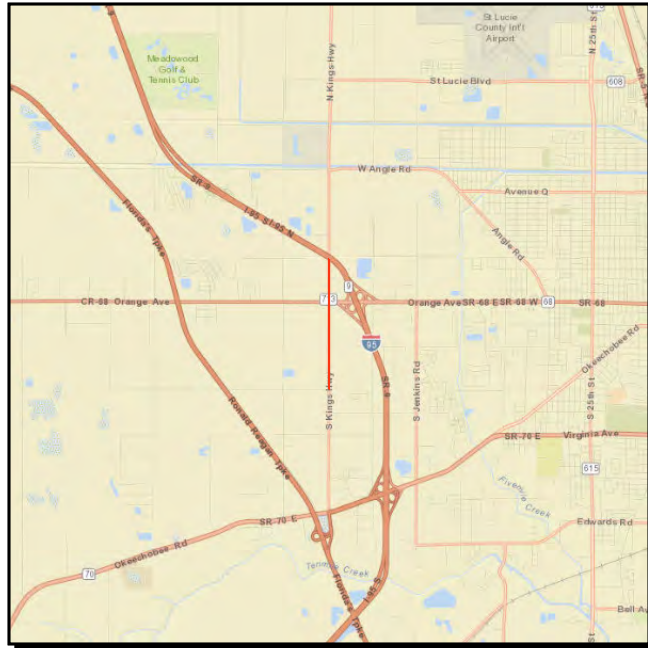

**Project Description:** DESIGN OF STAND ALONE LANDSCAPE PROJECT LANDSCAPE FOR 230256-7

**Work Summary:** LANDSCAPING  
**From:** NORTH OF PICOS RD  
**To:** NORTH OF SR-9/I-95 OVERPASS

**Lead Agency:** Managed by FDOT  
**Length:** 1.552

Phase	Fund Source	2016/17	2017/18	2018/19	2019/20	2020/21	Total
PE	DDR	0	0	0	0	15,000	15,000
PE	DIH	0	0	0	0	5,000	5,000
<b>Total</b>		<b>0</b>	<b>0</b>	<b>0</b>	<b>0</b>	<b>20,000</b>	<b>20,000</b>

**Prior Year Cost:** 0  
**Future Year Cost:** 0  
**Total Project Cost:** 20,000  
**LRTP:** Page 7-1



**MOWING AND LITTER**

**2340035**

**Non-SIS**

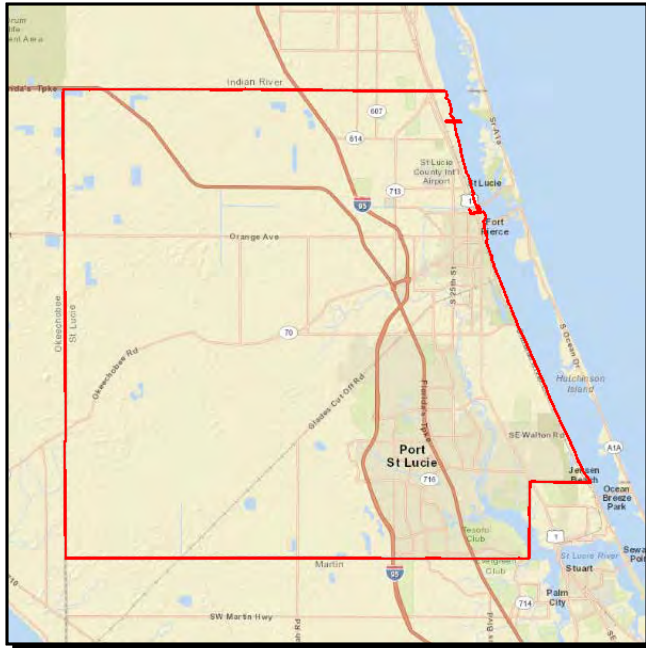

**Project Description:** MOWING AND LITTER

**Work Summary:** ROUTINE MAINTENANCE **From:**

**To:**

**Lead Agency:** FDOT

Phase	Fund Source	2016/17	2017/18	2018/19	2019/20	2020/21	Total
MNT	D	144,000	0	0	0	0	144,000
<b>Total</b>		<b>144,000</b>	<b>0</b>	<b>0</b>	<b>0</b>	<b>0</b>	<b>144,000</b>

**Prior Year Cost:** 288,000  
**Future Year Cost:** 0  
**Total Project Cost:** 432,000  
**LRTP:** Page 7-1

**MOWING AND LITTER**

**2340036**

**Non-SIS**

**Project Description:** ST. LUCIE - PRIMARY MOWING AND LITTER CONTRACT

**Work Summary:** ROUTINE MAINTENANCE **From:**

**To:**

**Lead Agency:** FDOT

**Length:** .000

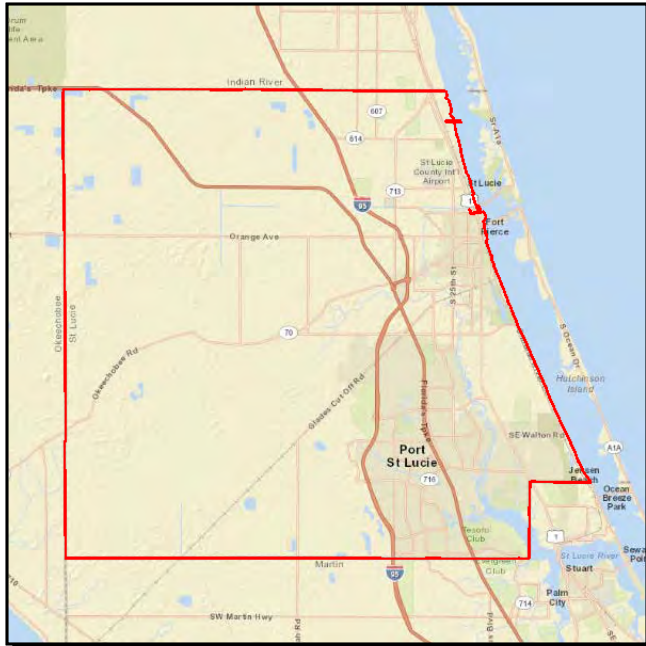

Phase	Fund Source	2016/17	2017/18	2018/19	2019/20	2020/21	Total
MNT	D	0	210,000	210,000	210,000	0	<b>630,000</b>
<b>Total</b>		<b>0</b>	<b>210,000</b>	<b>210,000</b>	<b>210,000</b>	<b>0</b>	<b>630,000</b>

**Prior Year Cost:** 0  
**Future Year Cost:** 0  
**Total Project Cost:** 630,000  
**LRTP:** Page 7-1

**ROUTINE MAINTAINANCE**

**2343761**

**SIS**



**Project Description:** ROUTINE MAINTENANCE OF INTERSTATE AND ROADWAY

**Work Summary:** ROUTINE MAINTENANCE **From:**

**To:**

**Lead Agency:** FDOT

Phase	Fund Source	2016/17	2017/18	2018/19	2019/20	2020/21	Total
MNT	D	400,000	100,000	100,000	100,000	0	<b>700,000</b>
<b>Total</b>		<b>400,000</b>	<b>100,000</b>	<b>100,000</b>	<b>100,000</b>	<b>0</b>	<b>700,000</b>

**Prior Year Cost:** 5,952,004  
**Future Year Cost:** 0  
**Total Project Cost:** 6,652,004  
**LRTP:** Page 7-1

**SIGN REPAIR/REPLACEMENT**

**2338591**

**Non-SIS**

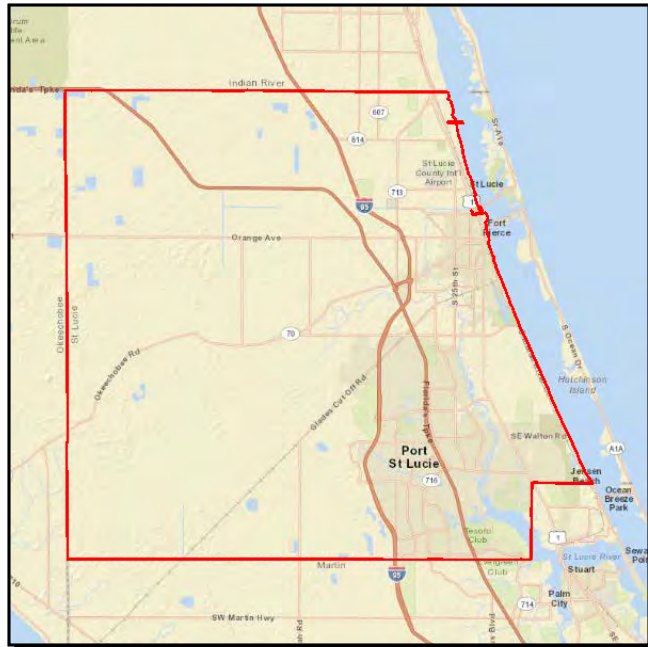

**Project Description:** ST LUCIE COUNTY SIGN REPAIR/REPLACEMENT ON STATE HWY SYSTEM

**Work Summary:** ROUTINE MAINTENANCE      **From:** STATE HWY SYS  
**To:** ROADWAY

**Lead Agency:** FDOT

Phase	Fund Source	2016/17	2017/18	2018/19	2019/20	2020/21	Total
MNT	D	2,200,000	2,200,000	2,200,000	2,200,000	0	8,800,000
<b>Total</b>		<b>2,200,000</b>	<b>2,200,000</b>	<b>2,200,000</b>	<b>2,200,000</b>	<b>0</b>	<b>8,800,000</b>

**Prior Year Cost:** 48,840,985  
**Future Year Cost:** 0  
**Total Project Cost:** 57,640,985  
**LRTP:** Page 7-1

**SIGN REPAIR/REPLACEMENT**

**2338592**

**Non-SIS**

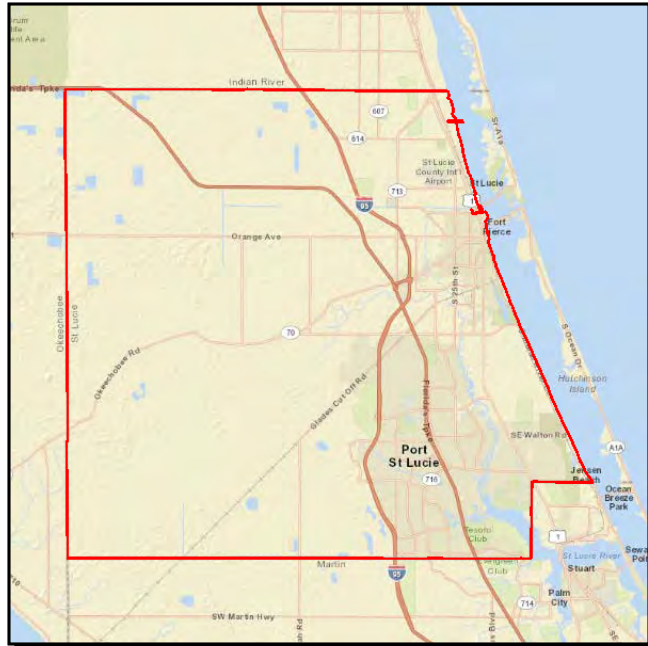

**Project Description:** SIGN REPAIR/REPLACEMENT ON STATE HWY SYSTEM ST. LUCIE CO STATE HWY SYS BRIDGES

**Work Summary:** ROUTINE MAINTENANCE **From:**

**To:**

**Lead Agency:** FDOT

**Length:** .000 M

Phase	Fund Source	2016/17	2017/18	2018/19	2019/20	2020/21	Total
MNT	D	70,000	70,000	70,000	70,000	0	280,000
<b>Total</b>		<b>70,000</b>	<b>70,000</b>	<b>70,000</b>	<b>70,000</b>	<b>0</b>	<b>280,000</b>

**Prior Year Cost:** 1,196,705  
**Future Year Cost:** 0  
**Total Project Cost:** 1,476,705  
**LRTP:** Page 7-1

**ST. LUCIE ROUTINE MAINTAINANCE**

**2343762**

**SIS**

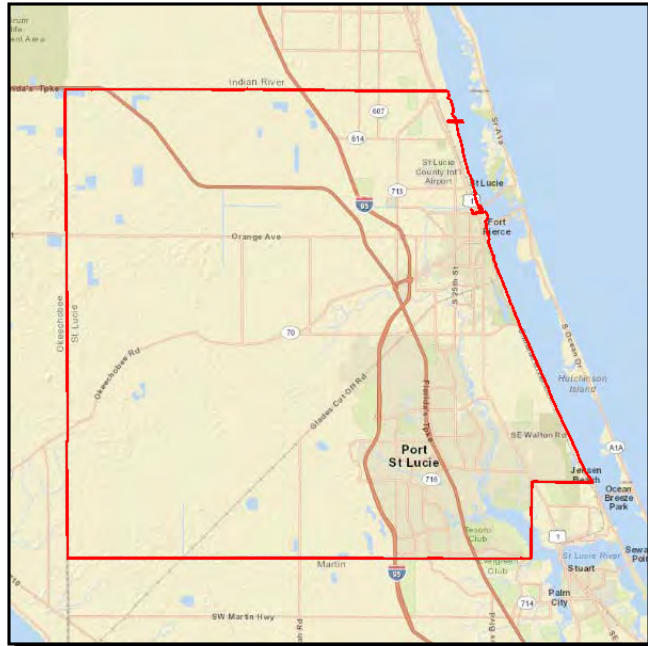

**Project Description:** ST. LUCIE CO INTERSTATE BRIDGES

**Work Summary:** ROUTINE MAINTAINANCE **From:**

**To:**

**Lead Agency:** Managed by FDOT **Length:** .000

Phase	Fund Source	2016/17	2017/18	2018/19	2019/20	2020/21	Total
MNT	D	5,000	2,000	2,000	2,000	0	11,000
<b>Total</b>		<b>5,000</b>	<b>2,000</b>	<b>2,000</b>	<b>2,000</b>	<b>0</b>	<b>11,000</b>

**Prior Year Cost:** 208,217  
**Future Year Cost:** 0  
**Total Project Cost:** 219,217  
**LRTP:** Page 7-1

---

**Section C 5 - Planning**

---



**SECTION 5305D**

**4137372**

**Non-SIS**

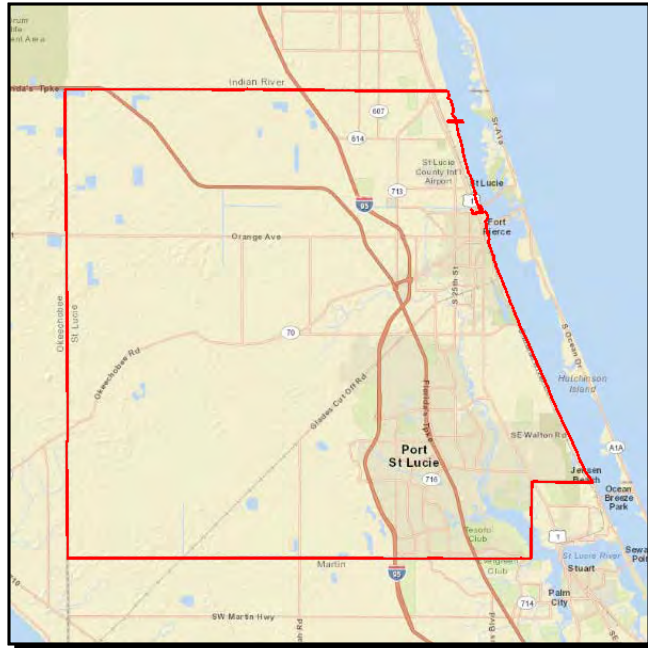

**Project Description:** Transit Planning funded by FTA and conducted by St. Lucie TPO

**Work Summary:** PTO STUDIES **From:**  
**To:**

**Lead Agency:** FDOT

Phase	Fund Source	2016/17	2017/18	2018/19	2019/20	2020/21	Total
PLN	DPTO	11,710	11,529	11,529	11,529	0	<b>46,297</b>
PLN	DU	93,679	92,229	61,465	71,465	92,229	<b>411,067</b>
PLN	LF	11,710	11,529	11,529	11,529	0	<b>46,297</b>
<b>Total</b>		<b>117,099</b>	<b>115,287</b>	<b>84,523</b>	<b>94,523</b>	<b>92,229</b>	<b>503,661</b>

**Prior Year Cost:** 147,855  
**Future Year Cost:** 0  
**Total Project Cost:** 651,516  
**LRTP:** Page 7-1

**UPWP FY 2016/17 - FY 2017/18**

**4236043**

**Non-SIS**

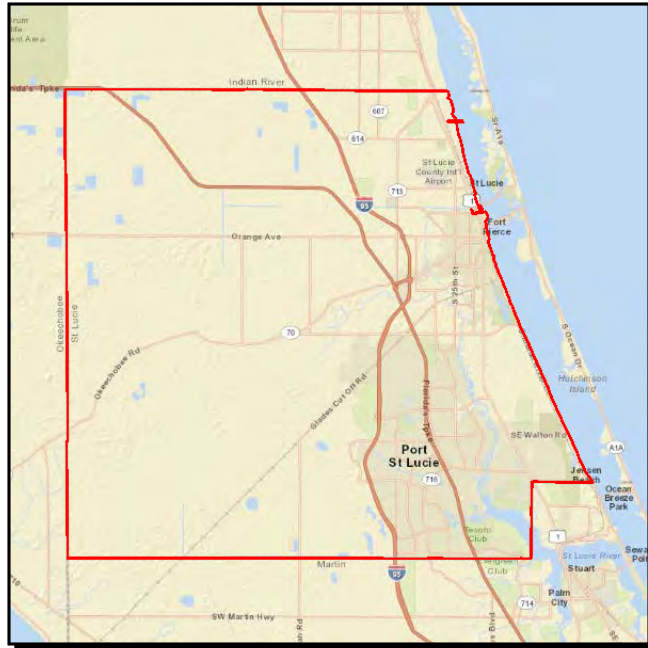

**Project Description:** Unified Planning Work Program (UPWP) FY 2016/17 & 2017/18

**Work Summary:** TRANSPORTATION PLANNING  
**From:** FY 2016/2017  
**To:** FY 2017/2018

**Lead Agency:** FDOT

Phase	Fund Source	2016/17	2017/18	2018/19	2019/20	2020/21	Total
PLN	PL	0	501,289	0	0	0	501,289
<b>Total</b>		<b>0</b>	<b>501,289</b>	<b>0</b>	<b>0</b>	<b>0</b>	<b>501,289</b>

**Prior Year Cost:** 0  
**Future Year Cost:** 0  
**Total Project Cost:** 501,289  
**LRTP:** Page 7-1

**UPWP FY 2018/19 - FY 2019/20**

**4236044**

**Non-SIS**

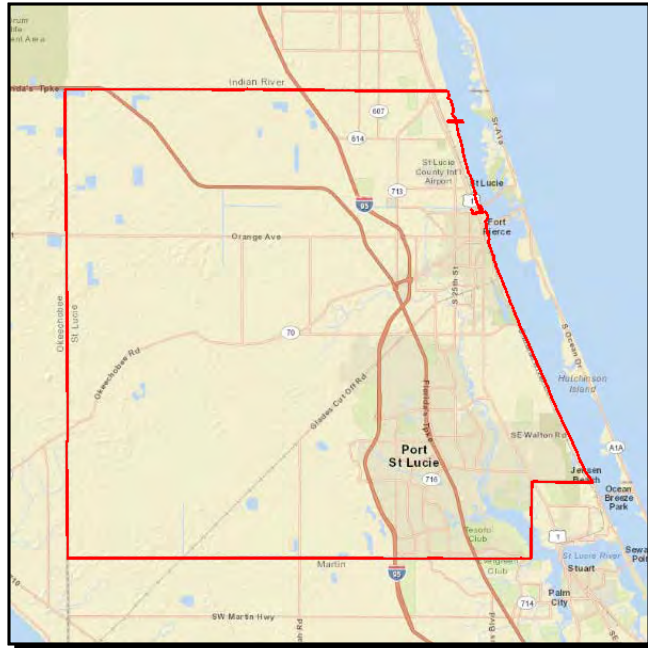

**Project Description:** Unified Planning Work Program (UPWP) FY 2018/2019 & 2019/2020

**Work Summary:** TRANSPORTATION PLANNING **From:** FY 2018/2019

**To:** FY 2019/2020

**Lead Agency:** ST LUCIE COUNTY **Length:** .000

Phase	Fund Source	2016/17	2017/18	2018/19	2019/20	2020/21	Total
PLN	PL	0	0	501,289	501,289	0	1,002,578
<b>Total</b>		<b>0</b>	<b>0</b>	<b>501,289</b>	<b>501,289</b>	<b>0</b>	<b>1,002,578</b>

**Prior Year Cost:** 0  
**Future Year Cost:** 0  
**Total Project Cost:** 1,002,578  
**LRTP:** Page 7-1

**UPWP FY 2020/21 - 2021/22**

**4236045**

**Non-SIS**



**Project Description:** ST. LUCIE UPWP FY 2020/2021 - 2021/2022

**Work Summary:** TRANSPORTATION PLANNING  
**From:** FY 2020/2021  
**To:** FY 2021/2022

**Lead Agency:** Responsible Agency Not Available  
**Length:** .000

Phase	Fund Source	2016/17	2017/18	2018/19	2019/20	2020/21	Total
PLN	PL	0	0	0	0	501,289	501,289
<b>Total</b>		<b>0</b>	<b>0</b>	<b>0</b>	<b>0</b>	<b>501,289</b>	<b>501,289</b>

**Prior Year Cost:** 0  
**Future Year Cost:** 0  
**Total Project Cost:** 501,289  
**LRTP:** Page 7-1

---

**Section C 6 - Bridge Projects**

---

**BRIDGE 940031 McCARTY ROAD**

**4343601**

**Non-SIS**

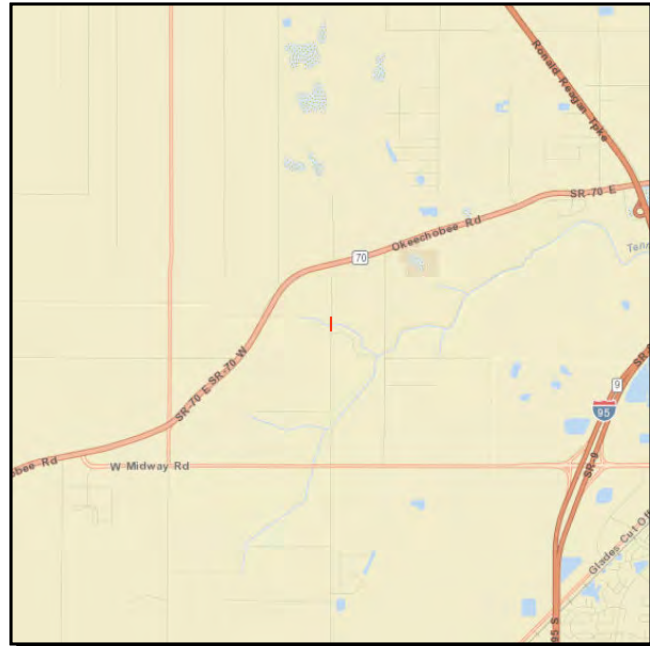

**Project Description:** REPLACE CR-712A/MCCARTY ROAD BRIDGE #940031 OVER NORTH CROSSING OF TEN MILE CREEK

**Work Summary:** BRIDGE REPLACEMENT **From:** South end of Bridge  
**To:** North End of Bridge

**Lead Agency:** Managed by FDOT **Length:** .023 MI

Phase	Fund Source	2016/17	2017/18	2018/19	2019/20	2020/21	Total
CST	SA	329,071	0	0	0	0	<b>329,071</b>
CST	ACBR	1,851,387	0	0	0	0	<b>1,851,387</b>
INC	SA	0	150,000	0	0	0	<b>150,000</b>
<b>Total</b>		<b>2,180,458</b>	<b>150,000</b>	<b>0</b>	<b>0</b>	<b>0</b>	<b>2,330,458</b>

**Prior Year Cost:** 512,484  
**Future Year Cost:** 0  
**Total Project Cost:** 2,842,942  
**LRTP:** Page 6-2

**BRIDGE 940045 N. CAUSEWAY**

**4299362**

**Non-SIS**

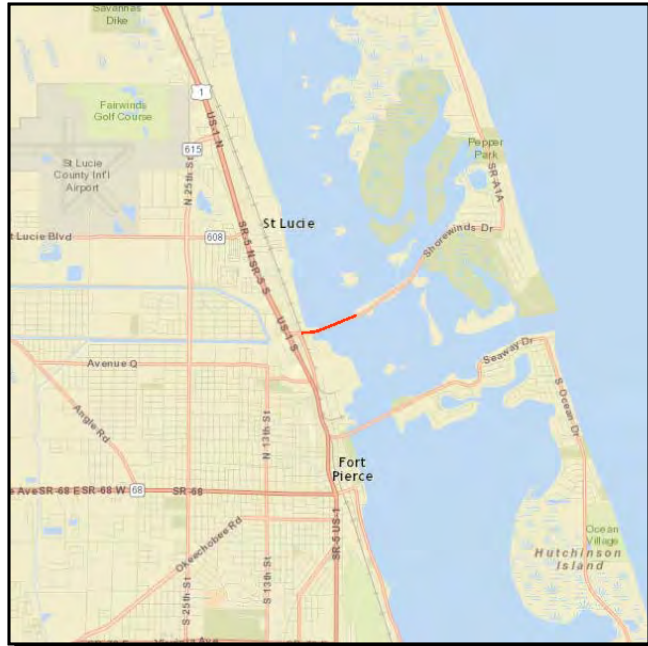

**Project Description:** REPLACE SR-A1A NORTH BRIDGE OVER ICWW BRIDGE #940045

**Work Summary:**

**From:** US 1

**To:** 2,000' East of East Bridge Terminus

**Lead Agency:**

Managed by FDOT

**Length:** .389 MI

Phase	Fund Source	2016/17	2017/18	2018/19	2019/20	2020/21	Total
ROW	ACBR	414,000	1,244,305	2,765,000	19,000	901,348	<b>5,343,653</b>
ENV	ACBR	525,000	0	0	0	0	<b>525,000</b>
ROW	BRP	0	2,000,000	0	925,000	0	<b>2,925,000</b>
RRU	ACBR	0	100,000	0	0	0	<b>100,000</b>
CST	SA	0	0	188,240	0	0	<b>188,240</b>
CST	DIH	0	0	167,442	0	0	<b>167,442</b>
CST	ACBR	0	0	41,852,552	0	0	<b>41,852,552</b>
CST	DDR	0	0	1,056,676	0	0	<b>1,056,676</b>
CST	DS	0	0	17,381,332	0	0	<b>17,381,332</b>
<b>Total</b>		<b>939,000</b>	<b>3,344,305</b>	<b>63,411,242</b>	<b>944,000</b>	<b>901,348</b>	<b>69,539,895</b>

**Prior Year Cost:** 7,375,405

**Future Year Cost:** 0

**Total Project Cost:** 76,915,300

**LRTP:** Page 6-2



**BRIDGE 940094 SEAWAY DRIVE**

**4268401**

**Non-SIS**

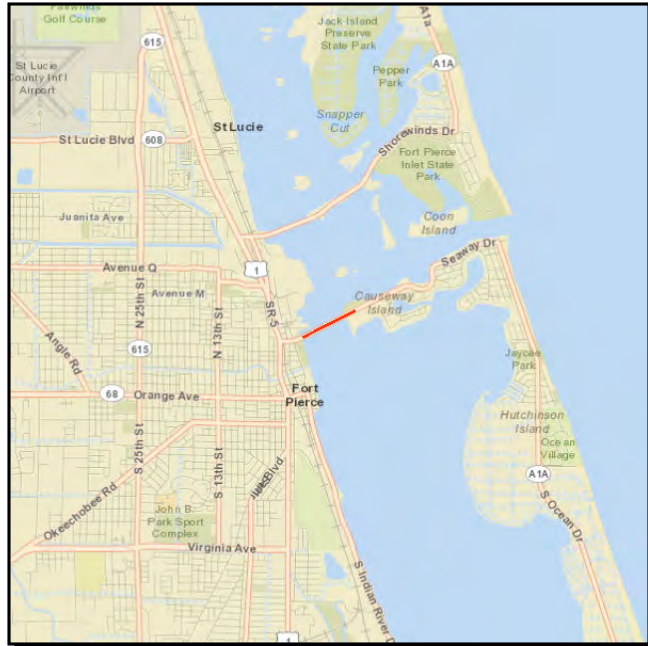

**Project Description:** South Causway Bridge Repair / Rehabilitation 940094  
SR-A1A PETER J. COBB

**Work Summary:** **From:** East end of Bridge  
**To:** West End of Bridge

**Lead Agency:** Managed by FDOT **Length:** .023 miles

Phase	Fund Source	2016/17	2017/18	2018/19	2019/20	2020/21	Total
CST	BRRP	5,833,146	0	0	0	0	5,833,146
CST	DIH	148,133	0	0	0	0	148,133
<b>Total</b>		<b>5,981,279</b>	<b>0</b>	<b>0</b>	<b>0</b>	<b>0</b>	<b>5,981,279</b>

**Prior Year Cost:** 574,885  
**Future Year Cost:** 0  
**Total Project Cost:** 6,556,164  
**LRTP:** Page 6-2

**Section C 7 - Turnpike Enterprise Projects**

---

**BRIDGE 940050 MIDWAY ROAD**

**4354101**

**SIS**

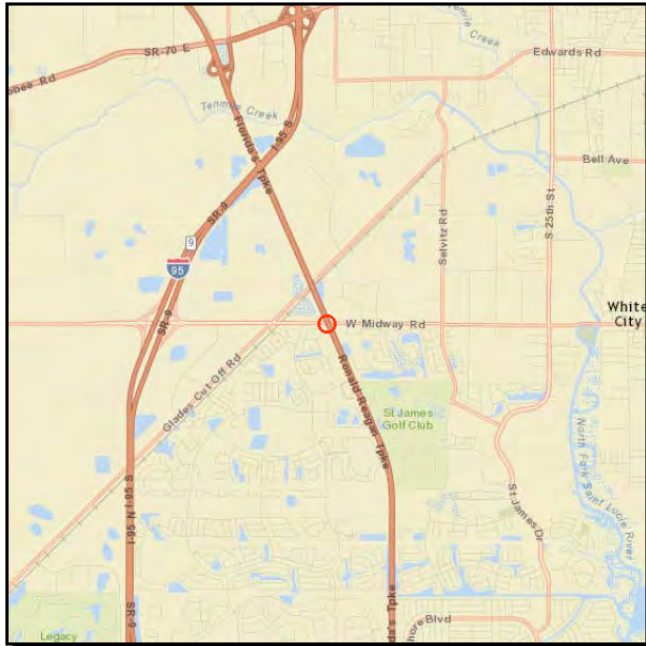

**Project Description:** PAINT BRIDGE 940050, (CR 712 / MIDWAY RD, OVER TPK) (TPK MP 150.5)

**Work Summary:**

**From:**

**To:**

**Lead Agency:**

Managed by FDOT

**Length:** .032 MI

Phase	Fund Source	2016/17	2017/18	2018/19	2019/20	2020/21	Total
PE	PKYR	44,920	0	0	0	0	<b>44,920</b>
CST	PKYR	0	328,351	0	0	0	<b>328,351</b>
<b>Total</b>		<b>44,920</b>	<b>328,351</b>	<b>0</b>	<b>0</b>	<b>0</b>	<b>373,271</b>

**Prior Year Cost:** 231  
**Future Year Cost:** 0  
**Total Project Cost:** 373,502  
**LRTP:** Page 7-1

---

**Section C 8 - Seaport Projects**

---

**PORT OF FT. PIERCE FISHERMAN'S WHARF PROPERTY**

**4387911**

**Non-SIS**



**Project Description:** JPA WITH PORT OF FT. PIERCE FOR PROPERTY ACQUISITION

**Work Summary:** SEAPORT CAPACITY PROJECT **From:**

**To:**

**Lead Agency:** Responsible Agency Not Available **Length:** .000

Phase	Fund Source	2016/17	2017/18	2018/19	2019/20	2020/21	Total
CAP	PORT	255,000	0	0	0	0	255,000
ADM	DDR	255,000	0	0	0	0	255,000
<b>Total</b>		<b>510,000</b>	<b>0</b>	<b>0</b>	<b>0</b>	<b>0</b>	<b>510,000</b>

**Prior Year Cost:** 255,000  
**Future Year Cost:** 0  
**Total Project Cost:** 765,000  
**LRTP:** Page 7-1

**D. LIST OF PRIORITY PROJECTS**



## 2015/16 List of Priority Projects (LOPP)

(Adopted August 5, 2015)

### Master List

2015/16 Priority Ranking	Major Gateway Corridor? <sup>1</sup>	Facility	Project Limits		Project Description	Project Status/Notes	In RL RTP <sup>2</sup> Cost Feasible Plan?	Estimated Cost	2014/15 Priority Ranking
			From	To					
1	Yes	Port St. Lucie Boulevard	Paar Drive	Darwin Boulevard	Add 2 lanes, sidewalks, bicycle lanes	PE <sup>3</sup> in process	Yes	\$11,700,000 <sup>4</sup>	2
2	Yes	Midway Road	Glades Cut Off Road	Selvitz Road	Add 2 lanes, sidewalks, bicycle lanes	PD&E <sup>5</sup> in process	Yes	\$19,000,000 <sup>6</sup>	3
3	N/A <sup>7</sup>	U.S. Highway 1 Intersection	At Virginia Avenue		Construct SB right-turn lane	PE to start in FY 2016/17	Yes	\$1,537,000 <sup>8</sup>	4
4	N/A	St. Lucie TPO Advanced Transportation Management System (ATMS) Phase I	U.S. Highway 1		Fiber optic infrastructure, cameras, poles, and data collection devices to connect 56 intersections	PE in process	Yes	\$3,300,000 <sup>9</sup>	5
			Turnpike Feeder Road	Savanna Club Boulevard					
			Okeechobee Road (SR-70)						
			Kings Highway	U.S. Highway 1					
5	Yes	Port St. Lucie Boulevard	Becker Road	Paar Drive	Add 2 lanes, sidewalks, bicycle lanes		Yes	\$9,600,000 <sup>4</sup>	6
6	Yes	Kings Highway	I-95 Overpass	St. Lucie Boulevard	Add 2 lanes, sidewalks, bicycle lanes		Yes	\$29,520,000 <sup>10</sup>	N/R <sup>11</sup>

<sup>1</sup>Landscape funding eligibility for capacity projects based on 2012 FDOT Landscape Policy

<sup>2</sup>RLRTP: *2035 St. Lucie/Martin Regional Long Range Transportation Plan, February 2011*

<sup>3</sup>PE: Preliminary Engineering

<sup>4</sup>Source: *Port St. Lucie Boulevard, Becker Road to Darwin Boulevard Project Development & Environment Study, September 2014*

<sup>5</sup>PD&E: Project Development & Environment Study

<sup>6</sup>Source: *2035 St. Lucie/Martin Regional Long Range Transportation Plan, February 2011*

<sup>7</sup>N/A: Not Applicable

<sup>8</sup>Source: *St. Lucie TPO Transportation Improvement Program FY 2015/16 – FY 2019/20*

<sup>9</sup>Source: *Advanced Transportation Management System (ATMS) Master Plan for St. Lucie County, February 2013*

<sup>10</sup>Source: *Kings Highway Project Development & Environment Study, July 2012*

<sup>11</sup>N/R: Not Ranked



## Congestion Management Process (CMP) List

*(The St. Lucie TPO's allocation of urban-attributable Federal funds to CMP projects is \$300,000 - \$400,000 annually)*

<b>2015/16 Priority Ranking</b>	<b>Facility/Intersection</b>	<b>Project Description</b>	<b>Project Status/Notes</b>	<b>Estimated Cost<sup>1</sup></b>	<b>CMP Plan<sup>2</sup> Ranking</b>	<b>2014/15 Priority Ranking</b>
1	California Boulevard at University Boulevard	Construct a roundabout		\$350,000	1	1
2	California Boulevard at Del Rio Boulevard	Construct a roundabout		\$350,000	2	2
3	St. Lucie West Boulevard at Peacock Boulevard	Extend the southbound innermost left-turn lane and incorporate signal timing adjustments		\$100,000	3	3
4	Port St. Lucie Boulevard at Floresta Boulevard	Extend westbound right-turn lane		\$350,000	4	4

<sup>1</sup>Source of Estimated Cost: CMP Plan, unless otherwise noted

<sup>2</sup>CMP Plan: *St. Lucie Transportation Planning Organization Congestion Management Process Revised Implementation Plan, 2015*

## Transit

2015/16 Priority Ranking	Facility/Equipment/Service	Project Location/Description	Is funding for Capital or Operating?	In RLRTP <sup>1</sup> or TDP <sup>2</sup> ?	Estimated Cost <sup>3</sup>	2014/15 Priority Ranking
1	Vehicle Purchases	New/replacement buses for new and expanded services as specified in TDP	Capital	Yes	\$2,000,000	1
2	Bus Stop and Park and Ride Infrastructure	Miscellaneous locations along the fixed routes with priority at transfer locations	Capital	Yes	\$75,000 (for bus shelters)	7
3	Expanded Local Services	Routes 1, 2 & 3 - Improve frequency to 30 minutes	Operating	Yes	\$1,000,000	4
4	New Bus Services	New bus service via intermodal facility along 25th Street	Operating	Yes	\$500,000	N/R <sup>4</sup>
5	I-95 Express Regional Bus Service	To Palm Beach County	Operating	Yes	\$500,000	6
6	St. Lucie Transit Administration and Operations Facility	Centralized facility for transit operations and bus maintenance	Capital	Yes	\$9,800,000	8

<sup>1</sup>RLRTP: 2035 St. Lucie/Martin Regional Long Range Transportation Plan, February 2011

<sup>2</sup>TDP: St. Lucie County FY 2015-FY 2024 Transit Development Plan Major Update, June 2014

<sup>3</sup>Source of Estimated Cost: Tables 9-1, 9-3, 9-9, and 9-10 of TDP, unless otherwise noted

<sup>4</sup>N/R: Not Ranked

## Transportation Alternatives (TA) Projects

2015/16 Priority Ranking	Score <sup>1</sup>	Facility	Project Limits		Project Description	Project Source	Estimated Cost <sup>2</sup>	2014/15 Priority Ranking
			From	To				
1	40.0	Parr Drive	Port St. Lucie Boulevard	Darwin Boulevard	Sidewalk-1.0 miles	2015 TA Grant Application <sup>3</sup>	\$569,984	8
2	34.0	Oleander Avenue	Midway Road	Market Avenue	Sidewalk-1.3 miles	2015 TA Grant Application <sup>4</sup>	\$917,653	16
3	46.5	Walton Road	Lennard Road	Green River Parkway	Sidewalk-1.1 miles	St. Lucie County School District	\$483,000	2
4	43.5	17th Street Sidewalk Gaps	Georgia Avenue	Avenue Q	Sidewalk-1.7 miles	2010/11 LOPP	\$170,000 <sup>5</sup>	3
5	43.0	East Torino Parkway	Volucia Drive	Conus Street	Sidewalk-0.4 miles	St. Lucie County School District	\$168,000	4
6	42.0	East Torino Parkway	Peacock Apartments	C-106 Canal	Sidewalk-0.3 miles	2013 TA Grant Application	\$207,730	5
7	41.5	North Macedo Boulevard	Selvitz Road	St. James Drive	Sidewalk-1.0 miles	Port St. Lucie Sidewalk List	\$525,220	6
7	41.5	Selvitz Road	Milner Drive	Peachtree Boulevard	Sidewalk-0.8 miles	2010/11 LOPP	\$337,920 <sup>6</sup>	6
9	38.5	Thornhill Drive	Bayshore Boulevard	Airosa Boulevard	Sidewalk-1.0 miles	Port St. Lucie Sidewalk List	\$594,820	9
10	36.5	Parr Drive	Savona Boulevard	Port St. Lucie Boulevard	Sidewalk-0.8 miles	Port St. Lucie Sidewalk List	\$344,050	10
10	36.5	29th Street Sidewalk Gaps	Avenue I	Avenue Q	Sidewalk-0.5 miles	2010/11 LOPP	\$50,000 <sup>5</sup>	10
10	36.5	Boston Avenue	25th Street	13th Street	Sidewalk-0.8 miles	2010/11 LOPP	\$80,000 <sup>5</sup>	10
13	36	Floresta Drive	Port St. Lucie Boulevard	Streamlet Avenue	Sidewalk-1.0 mile	Port St. Lucie Sidewalk List #7	\$759,730	13
14	35.5	Curtis Street	Prima Vista Boulevard	Floresta Drive	Sidewalk-0.5 miles	Port St. Lucie Sidewalk List	\$461,620	14
15	34.5	Weatherbee Road	U.S. Highway 1	Oleander Avenue	Sidewalk-0.5 miles	St. Lucie County School District	\$226,000	15
16	34.0	Oleander Avenue	Midway Road	Saeger Avenue	Sidewalk-1.5 miles	St. Lucie County School District	\$672,000	16
16	34.0	Volucia Drive	Blanton Boulevard	Torino Parkway	Sidewalk-1.0 miles	St. Lucie County School District	\$441,840	16
18	32.5	29th Street	Avenue Q	Avenue T	Sidewalk-0.1 miles	2010/11 LOPP	\$10,000 <sup>5</sup>	19
19	31.5	Alcantarra Boulevard	Port St. Lucie Boulevard	Savona Boulevard	Sidewalk-0.8 miles	St. Lucie County School District	\$357,000	20
20	29.5	Floresta Drive	Port St. Lucie Boulevard	Southbend Boulevard	Sidewalk-0.6 miles	Port St. Lucie Sidewalk List #8	\$489,821	21
21	28.5	Rosser Boulevard	Newport Isle	Bamberg Street	Sidewalk-2.1 miles	Port St. Lucie Sidewalk List #1	\$1,014,813	22
22	25.5	Import Drive	Gatlin Boulevard	Savage Boulevard	Sidewalk-2.0 miles	Port St. Lucie Sidewalk List #3	\$1,255,161	23

2015/16 Priority Ranking	Score <sup>1</sup>	Facility	Project Limits		Project Description	Project Source	Estimated Cost <sup>2</sup>	2014/15 Priority Ranking
			From	To				
23	21.5	Paar Drive	Bamberg Street	Savona Boulevard	Sidewalk-0.8 miles	Port St. Lucie Sidewalk List #2	\$1,014,728	24
23	21.5	Southbend Boulevard	Oakridge Drive	Eagle Drive	Bridge and Sidewalk- 0.2 miles	Port St. Lucie Sidewalk List #13	\$1,526,084	24
25	20.5	Savage Boulevard	Import Drive	Gatlin Boulevard	Sidewalk-1.7 miles	Port St. Lucie Sidewalk List #4	\$1,293,199	26
25	20.5	Bayshore Boulevard	Mountwell Street	Port St. Lucie Boulevard	Sidewalk-0.8 miles	Port St. Lucie Sidewalk List #6	\$695,496	26
25	20.5	Emil Avenue	Oleander Avenue	U.S. Highway 1	Sidewalk-0.4 miles	2014 TA Grant Application	\$347,487	26
28	20.0	Traffic Signal Preemption Technology	Various	Various	50 Intersections 55 Fire/EMS vehicles	St. Lucie County Fire District	\$750,000	29
29	19.5	Oakridge Drive	Southbend Drive	Mountwell Street	Sidewalk-0.8 miles	Port St. Lucie Sidewalk List #5	\$736,575	30
29	19.5	Tiffany Avenue	Lennard Road	Grand Drive	Sidewalk-0.9 miles	Port St. Lucie Sidewalk List #9	\$365,843	30
29	19.5	Selvitz Road	Floresta Drive	Bayshore Boulevard	Sidewalk-0.5 miles	Port St. Lucie Sidewalk List #10	\$962,435	30
29	19.5	Cashmere Boulevard	Charter School	Westgate K-8 School	Sidewalk-1.0 miles	Port St. Lucie Sidewalk List #11	\$590,464	30
29	19.5	Idol Drive	Charter School	Savona Boulevard	Sidewalk-0.7 miles	Port St. Lucie Sidewalk List #12	\$483,037	30
34	17.0	Bicycle Facilities Improvement Program	Various	Various	Install various bicycle facilities	2011 TE Grant Application	\$401,353	35
35	5.0	West Cedar Pedestrian Mall	2nd Street	FEC Railroad	Streetscape improvements	2011 TE Grant Application	\$440,756	36

<sup>1</sup>Scoring is based on the St. Lucie TPO TA Project Prioritization Methodology

<sup>2</sup>Source of Estimated Cost: Project Source, unless otherwise noted

<sup>3</sup>Construction funding is anticipated to be fully programmed in the upcoming FDOT Tentative Work Program as a result of the 2015 TA Grant Cycle

<sup>4</sup>Construction funding was partially awarded as a result of the 2015 TA Grant Cycle

<sup>5</sup>Estimated cost is based on an assumed cost of \$100,000 per mile

<sup>6</sup>Source: City of Port St. Lucie Engineering Department

**E. PERFORMANCE MANAGEMENT**

Table E-1 presents the performance measures for the Go2040 LRTP and demonstrates their consistency with proposed State and Federal performance measures.

**Table E-1: Goals, Objectives and Performance Measures**

Goals		Objectives	Performance Measures	MAP-21 PM	FDOT PM
1	Economic Prosperity and Growth	Enable people and goods to move around efficiently.	Lane miles of additional capacity along existing congested (V/C>0.85) corridors	Yes	Yes
			% truck miles severely congested	Yes	Yes
		Increase transportation options and improve access to destinations that support prosperity and growth.	% population within ¼ mile of Activity Centers		
			Transit routes providing access to Activity Centers		
2	Choices	Improve bike/pedestrian and public transportation networks.	% of roadways with sidewalks and bike lanes	Yes	Yes
			% of transit stops with sidewalk access	Yes	Yes
		Provide for transportation needs of transportation disadvantaged that may include use of automated vehicles.	Miles of fixed route transit service	Yes	Yes
			% of low-income, older adults, persons with disabilities within ¼ mile of transit route	Yes	Yes
3	Existing Assets and Services	Maintain condition of existing transportation assets.	Pavement condition, 70 or less		
			Bridge condition, 50 or less		
			Percent transit fleet beyond useful life		
		Improve efficiency of existing transportation services.	VMT of roads operating at adopted LOS		
4	Cooperation	Facilitate unified transportation decision-making through intergovernmental cooperation.	Attendance at TPO meetings		
			Collaboration opportunities with local and resource agencies		
		Ensure community participation is representative.	Collaboration opportunities with community and public groups		
			Opportunities for engagement in traditionally underserved areas		
5	Health and Environment	Support healthy living strategies, programs, and improvements.	Community Walkscores		
			Number of bicycle riders		
		Make transportation investments that minimize impacts to natural environment and allocate resources toward mitigation.	Number of additional roadway lane miles of impacting environmentally-sensitive areas		
			Increase transit frequency and span of service		
6	Safety and Security	Improve safety of transportation system that may include incorporation of infrastructure in support of automated vehicles.	Number and rate of fatalities/serious injuries, motorized	Yes	Yes
			Number of fatalities/serious injuries, non-motorized	Yes	Yes
		Improve the transportation system's stability/resiliency in the event of climate change, emergencies or disasters	Number of projects permanently inundated by Mean Sea Level (MSL + 5 inches)		

Table E-2 presents initial performance targets. These performance targets are based on current available data. Performance targets may require additional data collection efforts by the TPO, and the performance measures will be updated going forward on an annual basis.

**Table E-2: LRTP Performance Targets**

Goal	Objectives	Performance Measures	E+C with 2040 SE Data	Adopted Needs Plan	Adopted Cost Feasible Plan
1	Enable people and goods to move around efficiently.	Lane miles of additional capacity along existing congested (V/C>0.85) corridors	Base	53	15
		% truck miles severely congested	16.07	1.575	2.87
	Increase transportation options and improve access to destinations that support prosperity and growth.	% population within ¼ mile of Activity Centers	21%	16%	16%
		Transit routes providing access to Activity Centers	7	17	7
2	Improve bike/pedestrian and public transportation networks.	% of roadways with sidewalks and bike lanes	46%	59%	43%
		% of transit stops with sidewalk access	86%	85%	86%
	Provide for transportation needs of transportation disadvantaged that may include use of automated vehicles.	Miles of fixed route transit service	74	104	74
		% of low-income, older adults, persons with disabilities within ¼ mile of transit route	25%	33%	19%
3	Maintain condition of existing transportation assets.	Pavement condition, 70 or less	n/a	n/a	n/a
		Bridge condition, 50 or less	n/a	n/a	n/a
		Percent transit fleet beyond useful life	n/a	n/a	n/a
	Improve efficiency of existing transportation services.	VMT of roads operating at adopted LOS	440,060	474,940	456,076
		Passenger trips per vehicle mile of service <sup>(1)</sup>	0.57	n/a	n/a
4	Facilitate unified transportation decision-making through intergovernmental cooperation.	Attendance at TPO meetings	n/a	n/a	n/a
		Collaboration opportunities with local and resource agencies	n/a	n/a	n/a
	Ensure community participation is representative.	Collaboration opportunities with community and public groups	13	12	8
		Opportunities for engagement in traditionally underserved areas	6	6	4
5	Support healthy living strategies, programs, and improvements.	Community Walkscores	n/a	n/a	n/a
		Number of bicycle riders	n/a	n/a	n/a
	Make transportation investments that minimize impacts to natural environment and allocate resources toward mitigation.	Number of additional roadway lane miles impacting environmentally-sensitive areas	5.51	32.96	0.01
		Increase transit frequency and span of service	60 min	Routes 1-3: 30 min. headway, add Saturday Service; 10 new routes	Routes 1-3: 30 min. headway, add Saturday Service
6	Improve safety of transportation system that may include incorporation of infrastructure in support of automated vehicles.	Number and rate of fatalities/serious Injuries, motorized <sup>(2)</sup>	17 / 348	n/a	n/a
		Number of fatalities/serious Injuries, non-motorized <sup>(3)</sup>	21 / 602	n/a	n/a
	Improve the transportation system's stability/resiliency in the event of climate change, emergencies or disasters	Number of projects permanently inundated by Mean Sea Level (MSL + 5 inches) <sup>(4)</sup>	0	0	0

1 – National Transit Database, 2014 Reporting Year; 2 – Motorcycle crashes from 2010 to 2014 reported in St. Lucie County.;

3 – Pedestrian and bicycle crashes from 2010 to 2014 reported in St. Lucie County.; 4 – Results from Florida Sea Level Scenario Sketch Planning Tool, based on USACE High projections in 2040.

Appendix

A

Example Public Comment Notice





## **TRANSPORTATION IMPROVEMENT PROGRAM PUBLIC COMMENT OPPORTUNITIES**

Public comment opportunities are provided for the draft FY 2016/17–FY 2020/21 Transportation Improvement Program (TIP) of the St. Lucie Transportation Planning Organization (TPO). The TIP identifies the phases of the transportation projects that are expected to occur within the TPO area over the next 5 years.

### **To Obtain the TIP for Review**

- 1) Appear in person or write to the St. Lucie TPO at 466 SW Port St. Lucie Boulevard, Suite 111, Port St. Lucie, Florida, 34953
- 2) Call 772-462-1593
- 3) Access the TPO website at [www.stlucietpo.org](http://www.stlucietpo.org)

### **To Provide Comments on the TIP**

- 1) Write to the St. Lucie TPO at 466 SW Port St. Lucie Blvd, Suite 111, Port St. Lucie, Florida, 34953
- 2) Call 772-462-1593
- 3) Email [TPOAdmin@stlucieco.org](mailto:TPOAdmin@stlucieco.org)
- 4) Appear in person at the following upcoming, public St. Lucie TPO Board Meeting:  
June 1, 2016, 2:00pm  
Coco Vista Centre  
466 SW Port St. Lucie Boulevard, Suite 111  
Port St. Lucie, Florida

### **For Special Assistance**

Disabled: Persons who require special accommodations under the Americans with Disabilities Act (ADA) or persons who require translation services (free of charge) should contact Marceia Lathou at 772-462-1593 at least five days prior to the meeting. Persons who are hearing or speech impaired may use the Florida Relay System by dialing 711.

Kreyol Aysiyen: Si ou ta renmen resevwa enfòmasyon sa a nan lang Kreyòl Aysiyen, tanpri rele nimewo 772-462-1593.

Español: Si usted desea recibir esta información en español, por favor llame al 772-462-1593.

Title VI Statement: The St. Lucie TPO satisfies the requirements of various nondiscrimination laws and regulations including Title VI of the Civil Rights Act of 1964. Public participation is welcome without regard to race, color, national origin, age, sex, religion, disability, income, or family status. Persons wishing to express their concerns about nondiscrimination should contact Marceia Lathou, the Title VI/ADA Coordinator of the St. Lucie TPO, at 772-462-1593 or via email at [lathoum@stlucieco.org](mailto:lathoum@stlucieco.org).

**AGENDA ITEM SUMMARY**

**Board/Committee:** Bicycle-Pedestrian Advisory Committee (BPAC)

**Meeting Date:** May 19, 2016

**Item Number:** 6b

**Item Title:** Transportation Alternatives Program (TAP) 2016 Grant Application

**Item Origination:** Fixing America’s Surface Transportation (FAST) Act

**UPWP Reference:** Task 3.3: Transportation Improvement Program  
 Task 3.5: Bicycle/Pedestrian/Greenway Planning

**Requested Action:** Review and recommend endorsement of the TAP grant application for the 2016 grant cycle, recommend endorsement with conditions, or do not recommend endorsement.

**Staff Recommendation:** Based on the inclusion of the project in the 2015/16 TA Priority Project List, it is recommended that the TPO advisory committees recommend to the TPO Board the endorsement of the North Macedo Boulevard Sidewalk Project for the allocation of the TAP funding from the 2016 grant cycle.

**Attachments**

- Staff Report
- 2015/16 TA Priority Project List
- North Macedo Boulevard Sidewalk Project Application Excerpts

## **MEMORANDUM**

**TO:** Bicycle-Pedestrian Advisory Committee (BPAC)

**FROM:** Peter Buchwald  
Executive Director

**DATE:** May 6, 2016

**SUBJECT:** **Transportation Alternatives Program (TAP)  
2016 Grant Application**

---

### **BACKGROUND**

The TAP was reauthorized by the Moving Ahead for Progress in the 21st Century Act (MAP-21) and was continued as a "set-aside" in the Fixing America's Surface Transportation (FAST) Act that was enacted last year. The program provides funding for the following:

- Construction, planning, and design of on-road and off-road trail facilities for pedestrians, bicyclists, and other non-motorized modes.
- Construction, planning, and design of infrastructure-related projects and systems that will provide safe routes for non-drivers, including children, older adults, and individuals with disabilities, to access daily needs.
- Conversion and use of abandoned railroad corridors for trails for pedestrians, bicyclists, or other non-motorized modes.
- Construction of turnouts, overlooks, and viewing areas.
- Community improvement activities, including:
  - inventory, control, or removal of outdoor advertising;
  - preservation and rehabilitation of historic transportation facilities;
  - vegetation management practices in transportation rights-of-way to improve safety, prevent against invasive species, and provide erosion control; and
  - archaeological activities relating to impacts from the implementation of a transportation project.

- Environmental mitigation activities, including pollution prevention and abatement activities, to:
  - address stormwater management and pollution prevention and abatement activities related to highway construction or runoff; or
  - reduce vehicle-caused wildlife mortality or to restore and maintain connectivity among terrestrial or aquatic habitats.
  
- The Recreational Trails Program.
  
- The Safe Routes to School Program.
  
- Planning, designing, or constructing boulevards and other roadways largely in the right-of-way of former Interstate System routes or other divided highways.

The funding available for the 2016 TAP grant cycle for the St. Lucie TPO is \$646,747 that will be programmed by the Florida Department of Transportation (FDOT) in Fiscal Year 2019/20. The TPO advisory committees recommend to the TPO Board the endorsement/prioritization of the TAP grant applications received during the grant cycle for submittal to FDOT. Candidate TAP Projects originate from the 2015/16 TA Priority Project List which is attached.

## **ANALYSIS**

A TAP grant application (attached) was received for the 2016 TAP grant cycle from the City of Port St. Lucie for the construction of a 5-foot wide concrete sidewalk, approximately one mile in length, on the south side of North Macedo Boulevard between St. James Drive and Selvitz Road. The project is estimated to cost \$872,243, and a total of \$719,776 of TAP grant funding is being requested. The North Macedo Boulevard Sidewalk Project is the 7th-ranked TA project on the 2015/16 TA Priority Project List.

## **RECOMMENDATION**

Based on the inclusion of the project in the 2015/16 TA Priority Project List, it is recommended that the TPO advisory committees recommend to the TPO Board the endorsement of the North Macedo Boulevard Sidewalk Project for the allocation of the TAP funding from the 2016 grant cycle.

## Transportation Alternatives (TA) Projects

2015/16 Priority Ranking	Score <sup>1</sup>	Facility	Project Limits		Project Description	Project Source	Estimated Cost <sup>2</sup>	2014/15 Priority Ranking
			From	To				
1	40.0	Parr Drive	Port St. Lucie Boulevard	Darwin Boulevard	Sidewalk-1.0 miles	2015 TA Grant Application <sup>3</sup>	\$569,984	8
2	34.0	Oleander Avenue	Midway Road	Market Avenue	Sidewalk-1.3 miles	2015 TA Grant Application <sup>4</sup>	\$917,653	16
3	46.5	Walton Road	Lennard Road	Green River Parkway	Sidewalk-1.1 miles	St. Lucie County School District	\$483,000	2
4	43.5	17th Street Sidewalk Gaps	Georgia Avenue	Avenue Q	Sidewalk-1.7 miles	2010/11 LOPP	\$170,000 <sup>5</sup>	3
5	43.0	East Torino Parkway	Volucia Drive	Conus Street	Sidewalk-0.4 miles	St. Lucie County School District	\$168,000	4
6	42.0	East Torino Parkway	Peacock Apartments	C-106 Canal	Sidewalk-0.3 miles	2013 TA Grant Application	\$207,730	5
7	41.5	North Macedo Boulevard	Selvitz Road	St. James Drive	Sidewalk-1.0 miles	Port St. Lucie Sidewalk List	\$525,220	6
7	41.5	Selvitz Road	Milner Drive	Peachtree Boulevard	Sidewalk-0.8 miles	2010/11 LOPP	\$337,920 <sup>6</sup>	6
9	38.5	Thornhill Drive	Bayshore Boulevard	Airosa Boulevard	Sidewalk-1.0 miles	Port St. Lucie Sidewalk List	\$594,820	9
10	36.5	Parr Drive	Savona Boulevard	Port St. Lucie Boulevard	Sidewalk-0.8 miles	Port St. Lucie Sidewalk List	\$344,050	10
10	36.5	29th Street Sidewalk Gaps	Avenue I	Avenue Q	Sidewalk-0.5 miles	2010/11 LOPP	\$50,000 <sup>5</sup>	10
10	36.5	Boston Avenue	25th Street	13th Street	Sidewalk-0.8 miles	2010/11 LOPP	\$80,000 <sup>5</sup>	10
13	36	Floresta Drive	Port St. Lucie Boulevard	Streamlet Avenue	Sidewalk-1.0 mile	Port St. Lucie Sidewalk List #7	\$759,730	13
14	35.5	Curtis Street	Prima Vista Boulevard	Floresta Drive	Sidewalk-0.5 miles	Port St. Lucie Sidewalk List	\$461,620	14
15	34.5	Weatherbee Road	U.S. Highway 1	Oleander Avenue	Sidewalk-0.5 miles	St. Lucie County School District	\$226,000	15
16	34.0	Oleander Avenue	Midway Road	Saeger Avenue	Sidewalk-1.5 miles	St. Lucie County School District	\$672,000	16
16	34.0	Volucia Drive	Blanton Boulevard	Torino Parkway	Sidewalk-1.0 miles	St. Lucie County School District	\$441,840	16
18	32.5	29th Street	Avenue Q	Avenue T	Sidewalk-0.1 miles	2010/11 LOPP	\$10,000 <sup>5</sup>	19
19	31.5	Alcantarra Boulevard	Port St. Lucie Boulevard	Savona Boulevard	Sidewalk-0.8 miles	St. Lucie County School District	\$357,000	20
20	29.5	Floresta Drive	Port St. Lucie Boulevard	Southbend Boulevard	Sidewalk-0.6 miles	Port St. Lucie Sidewalk List #8	\$489,821	21
21	28.5	Rosser Boulevard	Newport Isle	Bamberg Street	Sidewalk-2.1 miles	Port St. Lucie Sidewalk List #1	\$1,014,813	22
22	25.5	Import Drive	Gatlin Boulevard	Savage Boulevard	Sidewalk-2.0 miles	Port St. Lucie Sidewalk List #3	\$1,255,161	23

2015/16 Priority Ranking	Score <sup>1</sup>	Facility	Project Limits		Project Description	Project Source	Estimated Cost <sup>2</sup>	2014/15 Priority Ranking
			From	To				
23	21.5	Paar Drive	Bamberg Street	Savona Boulevard	Sidewalk-0.8 miles	Port St. Lucie Sidewalk List #2	\$1,014,728	24
23	21.5	Southbend Boulevard	Oakridge Drive	Eagle Drive	Bridge and Sidewalk- 0.2 miles	Port St. Lucie Sidewalk List #13	\$1,526,084	24
25	20.5	Savage Boulevard	Import Drive	Gatlin Boulevard	Sidewalk-1.7 miles	Port St. Lucie Sidewalk List #4	\$1,293,199	26
25	20.5	Bayshore Boulevard	Mountwell Street	Port St. Lucie Boulevard	Sidewalk-0.8 miles	Port St. Lucie Sidewalk List #6	\$695,496	26
25	20.5	Emil Avenue	Oleander Avenue	U.S. Highway 1	Sidewalk-0.4 miles	2014 TA Grant Application	\$347,487	26
28	20.0	Traffic Signal Preemption Technology	Various	Various	50 Intersections 55 Fire/EMS vehicles	St. Lucie County Fire District	\$750,000	29
29	19.5	Oakridge Drive	Southbend Drive	Mountwell Street	Sidewalk-0.8 miles	Port St. Lucie Sidewalk List #5	\$736,575	30
29	19.5	Tiffany Avenue	Lennard Road	Grand Drive	Sidewalk-0.9 miles	Port St. Lucie Sidewalk List #9	\$365,843	30
29	19.5	Selvitz Road	Floresta Drive	Bayshore Boulevard	Sidewalk-0.5 miles	Port St. Lucie Sidewalk List #10	\$962,435	30
29	19.5	Cashmere Boulevard	Charter School	Westgate K-8 School	Sidewalk-1.0 miles	Port St. Lucie Sidewalk List #11	\$590,464	30
29	19.5	Idol Drive	Charter School	Savona Boulevard	Sidewalk-0.7 miles	Port St. Lucie Sidewalk List #12	\$483,037	30
34	17.0	Bicycle Facilities Improvement Program	Various	Various	Install various bicycle facilities	2011 TE Grant Application	\$401,353	35
35	5.0	West Cedar Pedestrian Mall	2nd Street	FEC Railroad	Streetscape improvements	2011 TE Grant Application	\$440,756	36

<sup>1</sup>Scoring is based on the St. Lucie TPO TA Project Prioritization Methodology

<sup>2</sup>Source of Estimated Cost: Project Source, unless otherwise noted

<sup>3</sup>Construction funding is anticipated to be fully programmed in the upcoming FDOT Tentative Work Program as a result of the 2015 TA Grant Cycle

<sup>4</sup>Construction funding was partially awarded as a result of the 2015 TA Grant Cycle

<sup>5</sup>Estimated cost is based on an assumed cost of \$100,000 per mile

<sup>6</sup>Source: City of Port St. Lucie Engineering Department



**General Information:**

---

Project Title: North Macedo Boulevard Sidewalk

Project Sponsor (municipal, county, state, or federal agency, or tribal council): City of Port St. Lucie

Contact Person: Edith Majewski Title: Project Coordinator

Email: emajewski@cityofpsl.com

Sponsor Address: 121 SW Port St. Lucie Boulevard

City: Port St. Lucie Zip: 34984

Priority (relative to other applications submitted by the Project Sponsor):

Name of Applicant (If other than Project Sponsor):

The applicant

seeks project-specific LAP Certification

is currently LAP Certified

has never been LAP Certified

has been LAP certified in the last 5 years

**1 Qualifying Activities:**

---

Check the transportation alternatives activity that the proposed project will address. Please check **one** activity that represents the majority of the work proposed. (Note: Checking more activities does not ensure or increase eligibility.) Eligible activities must be consistent with details described under 23 U.S.C. 213(b).

- Construction of on-road and off-road trail facilities for pedestrians, bicyclists, and other non-motorized forms of transportation, including sidewalks, bicycle infrastructure, pedestrian and bicycle signals, traffic calming techniques, lighting and other safety-related infrastructure, and transportation projects to achieve compliance with the Americans with Disabilities Act of 1990
- Construction of infrastructure-related projects and systems that will provide safe routes for non-drivers, including children, older adults, and individuals with disabilities to access daily needs.
- Conversion and use of abandoned railroad corridors for trails for pedestrians, bicyclists, or other non-motorized transportation users
- Construction of turnouts, overlooks, and viewing areas
- Inventory, control, or removal of outdoor advertising
- Historic preservation and rehabilitation of historic transportation facilities
- Vegetation management practices in transportation rights-of-way to improve roadway safety, prevent against invasive species, and provide erosion control



- Archaeological activities relating to impacts from implementation of a transportation project eligible under title 23
- Any environmental mitigation activity, including pollution prevention and pollution abatement activities and mitigation to:
  - address stormwater management, control, and water pollution prevention or abatement related to highway construction or due to highway runoff, including activities described in sections 133(b)(11), 328(a), and 329 of title 23; or
  - reduce vehicle-caused wildlife mortality or to restore and maintain connectivity among terrestrial or aquatic habitats.
- The safe routes to school program under section 1404 of the SAFETEA-LU **note, Florida's Safe Routs to School Infrastructure application must accompany this application to be considered for funding.**
  - infrastructure-related projects on any public road or any bicycle or pedestrian pathway or trail in the vicinity of schools that will substantially improve the ability of students to walk and bicycle to school, including sidewalk improvements, traffic calming and speed reduction improvements, pedestrian and bicycle crossing improvements, on-street bicycle facilities, off-street bicycle and pedestrian facilities, secure bicycle parking facilities, and traffic diversion improvements in the vicinity of schools.
    - Application is attached
  - Noninfrastructure-related activities to encourage walking and bicycling to school, including public awareness campaigns and outreach to press and community leaders, traffic education and enforcement in the vicinity of schools, student sessions on bicycle and pedestrian safety, health, and environment, and funding for training, volunteers, and managers of safe routes to school programs.
- Constructing boulevards and other roadways largely in the right-of-way of former Interstate System routes or other divided highways.

**2 Project Description:** (all of the following items are **required** - applications without this information will not be reviewed)

Road Name: NW North Macedo Boulevard

Road Number:  Local Road  State Road

Project Limits: Begin: St. James Drive End: Selvitz Road

Begin Project Mile Post (MP): End Project MP:

A location map with an aerial view is attached. (Location\_Map.pdf)

(a) What is the scope of work for the project and where is the project located (what are the termini)?

A more detailed scope of work is attached. (Use attached Scope.doc)

Construct a 5-foot wide concrete sidewalk on the south side of North Macedo Boulevard between St. James Drive and Selvitz Road.

- (b) Summarize any special characteristics of project. Include a Typical Section depicting existing and proposed features and dimensions and right of way lines
- Typical section is attached (Typical\_Section.pdf)

The attached typical section depicts a 5-foot sidewalk being constructed 10-feet off the edge of pavement with open swale drainage behind the sidewalk.

- (c) **Right-of-Way acquisition is NOT permitted for Transportation Alternatives projects.** Describe the project's existing Right-of-Way ownerships. This description shall identify when the Right-of-Way was acquired and how ownership is documented (i.e. plats, deeds, prescriptions, certified surveys, easements).
- No Right-of-Way acquisition is proposed

The existing right-of-way is owned and maintained by the City of Port St. Lucie

- (d) Display the existing ownership with Right-of-Way maps to verify that all proposed work is within existing Right-of-Way currently owned by the Project Sponsor. Provide required right-of-way documentation (Right-of-Way.pdf):
- Right-of-Way maps are attached
- Plats, deeds, prescriptions, certified surveys, and/or easements are attached

- (e) Describe any related project work phases that are already complete or currently underway.
- This is not a phased project
- Previous phases of this project were constructed as LAP projects or JPA using FM numbers

- (f) Provide detailed project cost estimate. Estimate shall be broken down to FDOT typical pay items to allow for verification of eligible project costs. **Estimates are to be prepared and signed by a Professional Engineer from the Local Agency's Engineering office.**

Use the following links to access the basis of estimates manual as well as historical cost information for your area:

[Basis of Estimates Manual](#)

[Historical Cost Information](#)

- A detailed cost estimate is attached (Use attached Estimate.xlsx)

- (g) Other specific project information that should be considered.

This project will benefit Parkway Elementary School and the businesses located at the west end of this project. This project would connect to an existing sidewalk on St. James Boulevard and Selvitz Road which will greatly contribute to the connectivity that the City is trying to achieve.



### 3 Project Implementation Information:

---

Attach documentation as exhibits to this application.

- (a) Describe the proposed method of performing (i.e. contract or in-house) and administering (i.e. local or state) each work phase of the project. If it is proposed that the project be administered by a governmental entity other than the Department of Transportation, the Agency must be certified to administer Federal Aid projects in accordance with the Department's **Local Agency Program Manual (topic no. 525-010-300)**. Web site: [www.dot.state.fl.us/projectmanagementoffice/lap/default.htm](http://www.dot.state.fl.us/projectmanagementoffice/lap/default.htm)

- Design to be conducted by in-house staff
- Design to be conducted by FDOT pre-qualified consultant <sup>(1)</sup> <sup>(2)</sup>
- Design to be conducted by non-FDOT pre-qualified consultant <sup>(2)</sup>
- CEI to be conducted by in-house staff
- CEI to be conducted by FDOT pre-qualified consultant <sup>(1)</sup> <sup>(2)</sup>
- CEI to be conducted by non-FDOT pre-qualified consultant <sup>(2)</sup>

<sup>(1)</sup> FDOT pre-qualified consultants must be used on all design and CEI work for critical projects (a project is considered critical when it features a structure, has a budget greater than \$10 million and/or is on the State Highway System (SHS))

<sup>(2)</sup> Design consultant and CEI consultant shall not be the same.

- (b) Describe any public (and private, if applicable) support of the proposed project. (Examples include: written endorsement, formal declaration, resolution, financial donations or other appropriate means).

- (c) Describe the proposed ownership and maintenance responsibilities for the project when it is completed.

The ownership and maintenance of this sidewalk will be the sole responsibility of the City of Port St. Lucie.

- (d) Describe source of matching funds and any restrictions on availability.

The City of Port St. Lucie will incur all costs not covered by this grant.

- (e) Other specific implementation information that should be considered.

#### 4 Cost Estimate:

The total amount of Transportation Alternative Program (TAP\*\*) funds requested per projects (infrastructure) must be in excess of \$250,000 with a maximum of \$1,000,000 (though some T/MPO's may choose to use a lesser upper limit). Transportation Alternative Program funds will be used to fund Construction, Construction Engineering and Inspection Activities (CEI), and FDOT In-House Support Activities. Local Funds (LF) will be used for all non-participating items, contingency activities, and any costs in excess of the awarded alternatives (TAP) allocation.

Total Construction Cost Estimate: This is the total project construction cost estimate including all alternatives related items and any additional scope of work being identified.

Item Description	Cost \$
*(A) Total Construction Cost Estimate <sup>(1)</sup>	\$872,243.21
*(B) Cost Estimate of Eligible (participating) items <sup>(2)</sup>	\$616,620.21

Funding Breakdown	Fund Source	Cost \$
*(C) FDOT In-House Design Support (phase 31) <sup>(3)</sup> or *(D) (Critical projects only) FDOT In-House Design Support (phase 31) <sup>(3)</sup>	TAP	\$5,000.00
*(E) FDOT In-House Construction Support (phase 61) <sup>(3)</sup> or *(F) (Critical projects only) FDOT In-House Construction Support (phase 61) <sup>(3)</sup>	TAP	\$5,000.00
*(G) TAP funds requested for Construction (phase 58)	TAP	\$616,620.21
*(H) Local Funds for Construction (phase 58)	LF	\$22,078.46
*(I) Local Funds for Contingency ( <b>required</b> )	LF	\$127,739.73
*(J) TAP funds requested for Construction Engineering & Inspection (CEI) (phase 68 - optional) <sup>(4)</sup>	TAP	\$73,994.43
*(K) Local Funds for Construction Engineering & Inspection (CEI) <sup>(4)</sup>	LF	\$2,649.42
*(L) Transit Related projects FTA 10% administrative fees <sup>(5)</sup>	LF	\$0
*(M) FDOT Oversight CEI (3% of TOTAL Construction Cost) (phase 62) <sup>(6)</sup>	TAP	\$19,160.96

Funding Summary	
*(N) Total TAP funds	\$719,775.60
*(O) Total LF funds	\$152,467.61
*(P) Total Funds	\$872,243.21

\*Letters before the descriptions in the cost estimate above relate to the detailed cost estimate spreadsheet (Cost\_Estimate.xlsx) and should match the corresponding figures exactly.

\*\* Use of the term TAP represents the actual funding codes of TALT, TALU and TALL.

Notes:

- (1) The Total Construction Cost Estimate in this field must be equal to the Total Construction Cost Estimate from the attached detailed project cost estimate.
- (2) Cost Estimate of Eligible (participating) items must be equal to the Subtotal FHWA Participating from the attached detailed project cost estimate.
- (3) FDOT In-House Design and Construction Support must be included in TAP funds for an amount no less than \$5,000, an additional \$2,000 is required for critical projects. This is a required item.
- (4) It is strongly recommended that the applicant allocates a nominal amount for CEI. In the event that the project is programmed without any request for Phase 68 funding, there is no opportunity to allocate CEI funds based on bid savings.
- (5) Any required Federal Transit Authority (FTA) administrative fees must be included in Local Funds.
- (6) FDOT Oversight CEI must be included in TAP funds and be equal to 3% of the Total Construction Cost Estimate.



**5 Certification of Project Sponsor:**

I hereby certify that the proposed project herein described is supported by the City of Port St. Lucie (municipal, county, state or federal agency, or tribal council) and that said entity will: (1) provide any required funding match; (2) enter into a LAP and maintenance agreement with the Florida Department of Transportation; (3) comply with the Federal Uniform Relocation Assistance and Acquisition Policies Act for any Right of Way actions required for the project, (4) comply with NEPA process prior to construction, this may involve coordination with the State Historic and Preservation Office (SHPO) prior to construction. (Not at time of application) and (5) support other actions necessary to fully implement the proposed project. I further certify that the estimated costs and/or failure to follow through on the project once programmed in the Florida Department of Transportation's Work program included herein are reasonable. I understand that significant increases in these costs could cause the project to be removed from the Work Program and/or significantly increase the local agency match required.

James E. Angstadt  
Signature

JAMES E. ANGSTADT  
Name (please type or print)

PUBLIC WORK DIRECTOR  
Title

3/9/16  
Date

FOR FDOT USE ONLY		
Application Complete	<input type="checkbox"/> Yes	<input type="checkbox"/> No
Project Eligible	<input type="checkbox"/> Yes	<input type="checkbox"/> No
Implementation Feasible	<input type="checkbox"/> Yes	<input type="checkbox"/> No
<b>Include in Work Program</b>	<input type="checkbox"/> <b>Yes</b>	<input type="checkbox"/> <b>No</b>



North

Parkway Elementary School

Begin North Macedo Boulevard Sidewalk Project at St. James Drive

End North Macedo Boulevard Sidewalk Project at Selvitz Road

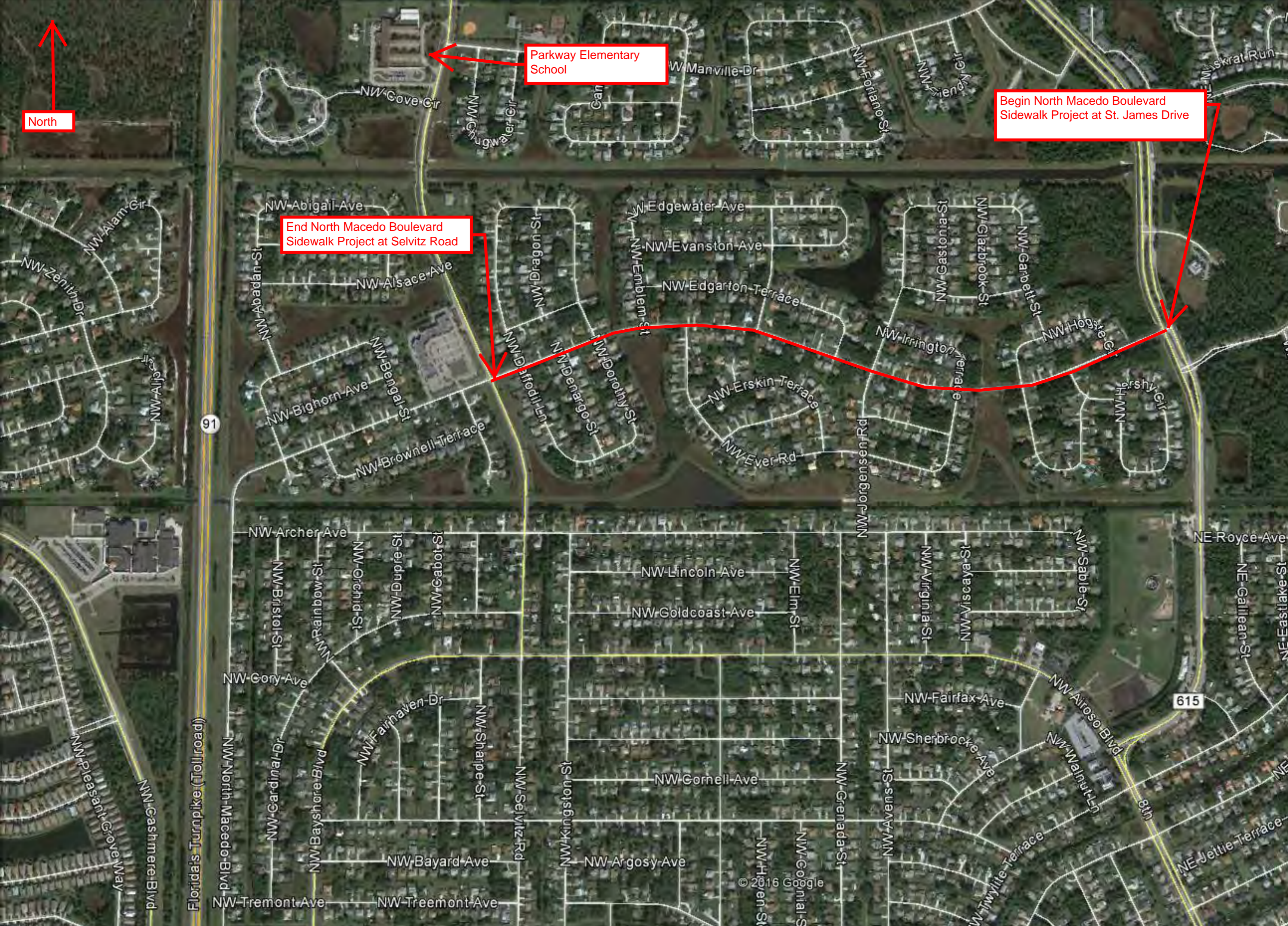





PUBLIC WORKS DEPARTMENT

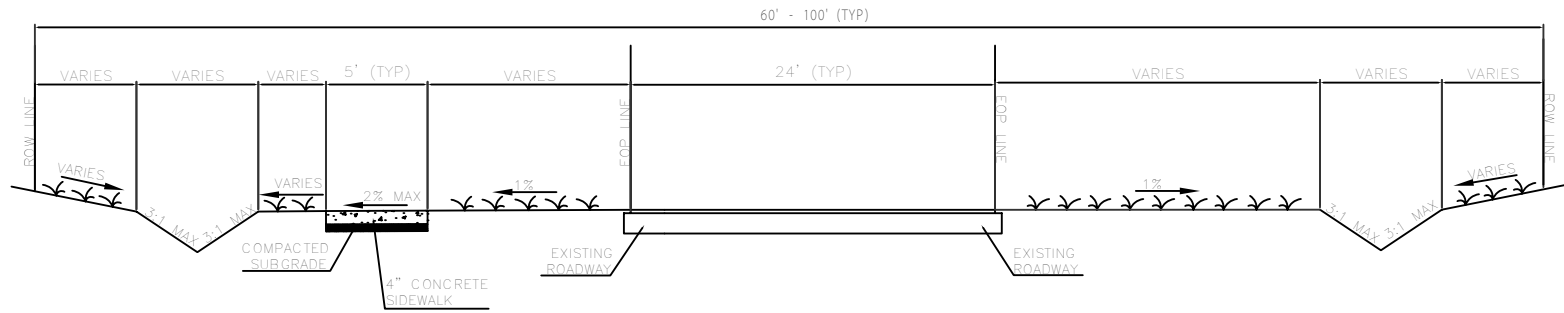

TYPICAL CROSS-SECTION DETAIL  
N.T.S.

TAP Grant Application FY 19/20

North Macedo Boulevard Sidewalk

St. James Drive to Selvitz Road



## AGENDA ITEM SUMMARY

<b>Board/Committee:</b>	Bicycle Pedestrian Advisory Committee (BPAC)
<b>Meeting Date:</b>	May 19, 2016
<b>Item Number:</b>	6c
<b>Item Title:</b>	Walton Road Multimodal Improvements Feasibility Study
<b>Item Origination:</b>	Unified Planning Work Program (UPWP)
<b>UPWP Reference:</b>	Task 4.1 – Walton Road Multimodal Improvements
<b>Requested Action:</b>	Review and recommend acceptance of the draft study, recommend acceptance with conditions, or do not recommend acceptance.
<b>Staff Recommendation:</b>	Based on the study evaluating the feasibility of multimodal improvements to Walton Road, it is recommended that the draft Walton Road Multimodal Improvements Feasibility Study be recommended for acceptance.

### **Attachments**

- Staff Report
- Draft Walton Road Multimodal Improvements Feasibility Study



Coco Vista Centre  
466 SW Port St. Lucie Blvd, Suite 111  
Port St. Lucie, FL 34953  
772-462-1593 www.stlucietpo.org

## **MEMORANDUM**

**TO:** Bicycle Pedestrian Advisory Committee (BPAC)

**THROUGH:** Peter Buchwald  
Executive Director

**FROM:** Ed DeFini

**DATE:** May 9, 2016

**SUBJECT: **Walton Road Multimodal Improvements Feasibility Study****

---

### **BACKGROUND**

Walton Road from Lennard Road to Indian River Drive is a substandard roadway facility because it does not include shoulders or any pedestrian or bicycle facilities. The FY 2014/15 – FY 2015/16 Unified Planning Work Program (UPWP) for the St. Lucie TPO includes Task 4.1, *Walton Road Multimodal Improvements*. The objective of Task 4.1 is to conduct a feasibility study of potential multimodal improvements to this segment of Walton Road.

### **ANALYSIS**

The draft Walton Road Multimodal Improvements Feasibility Study includes a detailed analysis and evaluates potential widening and multimodal improvements with respect to environmental, socio-cultural, and engineering factors. In order to consider improvements along Walton Road including bicycle and pedestrian infrastructure, the feasibility study evaluated “fatal flaws” associated with existing right-of-way ownership for potential corridor improvements. Stakeholder’s input and planning agency consensus was obtained through continuous and cooperative efforts, and the planning activities were coordinated with St. Lucie County and the City of Port St. Lucie.

The feasibility study was prepared by Stanley Consultants Inc. (SCI). SCI is one of the General Planning Consultants for the St. Lucie TPO. The Study contains an analyses of the existing conditions, bicycle and pedestrian mobility, and potential impacts and other environmental concerns.

The results of the study present an opportunity to extend the existing sidewalk on the north side of Walton Road from SE Scenic Park Street to Green River Parkway, extend a shared-use path from east of SE Rainer Road to Green River Parkway, and add on-street bike lanes in both directions.

In addition, the results of the study present an opportunity to extend the sidewalk on the north side of Walton Road from Green River Parkway to Indian River Drive and add on-street bike lanes in both directions.

Finally, kayak crossing options were evaluated in order to improve connectivity from the kayak launch located south of Walton Road to the Savannas Preserve State Park to the north. One option is for a kayak crossing under Walton Road through an arched culvert. A less costly option is to cross over Walton Road with a kayak portage which would require a mid-block pedestrian crossing signal and adequate ingress and egress from the waterway.

## **RECOMMENDATION**

Based on the study evaluating the feasibility of multimodal improvements to Walton Road, it is recommended that the draft Walton Road Multimodal Improvements Feasibility Study be recommended for acceptance.

# Walton Road Multimodal Improvements Feasibility Study

St. Lucie Transportation Planning Organization

Prepared for:



**St. Lucie** Transportation Planning Organization

Prepared by:



May 2016







# Table of Contents

<b>Executive Summary</b> .....	iii
<b>1.0 Introduction</b> .....	1-1
1.1 Study Area .....	1-1
1.2 Study Purpose and Need .....	1-3
<b>2.0 Existing Conditions Analysis</b> .....	2-1
2.1 Physical .....	2-1
2.2 Operation .....	2-5
2.3 Safety .....	2-6
2.4 Traffic .....	2-9
2.5 Environmental Conditions .....	2-10
2.6 Deficiencies .....	2-12
<b>3.0 Alternatives Evaluation</b> .....	3-1
3.1 Bike Lanes and Paved Shoulders .....	3-1
3.2 Sidewalks .....	3-2
3.3 Shared Use Path .....	3-3
3.4 Pedestrian Crossings .....	3-4
3.5 Recommended Alternatives .....	3-5
3.6 Total Alternative Costs .....	3-6
3.7 Other Multimodal Alternatives .....	3-7
3.7.1 Under Walton Road Option .....	3-7
3.7.2 Over Walton Road Option .....	3-8
<b>4.0 Conclusions and Recommendations</b> .....	4-1
4.1 Conclusions .....	4-1
4.2 Recommendations .....	4-2

## TABLES

Table 2.1 Crash Distribution by Year .....	2-6
Table 2.2 Crash Distribution by Weather Condition .....	2-7
Table 2.3 Crash Distribution by Lighting Condition .....	2-7
Table 2.4 Crash Distribution by Collision Type .....	2-7
Table 2.5 Location Distribution Year 2014 .....	2-8
Table 2.6 Crash Type for Year 2014 .....	2-8
Table 2.7 Location Distribution for Year 2015 .....	2-8
Table 2.8 Crash Type for Year 2015 .....	2-9
Table 2.9 Traffic Volumes and LOS for Walton Road .....	2-9



Table 2.10 Walton Road Two-Lane Section .....2-10  
 Table 3.1 Summary of Recommended Alternatives.....3-1  
 Table 3.2 Sidewalk Estimated Cost per Study Section .....3-3  
 Table 3.3 Shared Use Path Estimated Cost per Study Section .....3-4  
 Table 3.4 Estimated Roadway and Bike Lane Cost.....3-7  
 Table 3.5 Total Alternative Cost Estimate .....3-7  
 Table 4.1 Study Corridor Segment Description.....4-1  
 Table 4.2 Recommended Study Alternatives .....4-2

**FIGURES**

Figure 1.1 Overall Study Area .....1-2  
 Figure 1.2 Project Segment Map .....1-3  
 Figure 1.3 End of Shared Use Path .....1-3  
 Figure 1.4 End of Green River Parkway Trail .....1-4  
 Figure 1.5 Sidewalk on North .....1-4  
 Figure 2.1 Existing Right Of Way .....2-3  
 Figure 2.2 Walton Road Corridor (looking east).....2-4  
 Figure 2.3 Damaged Guardrail.....2-4  
 Figure 2.4 Intersection Lighting .....2-5  
 Figure 2.5 Speed Limit Sign .....2-5  
 Figure 2.6 Five Year Crash Distribution by Intersection Location .....2-6  
 Figure 2.7 Wetland Map .....2-10  
 Figure 2.8 Roadside Wetland.....2-10  
 Figure 2.9 Historic and Cultural Sites.....2-11  
 Figure 2.10 Walton Road Two-Lane Section .....2-12  
 Figure 3.1 Two Lane Section from Segment C .....3-2  
 Figure 3.2 Pedestrian Walking Along Walton Road .....3-2  
 Figure 3.3 Example of Pedestrian Crossing on Green River Parkway.....3-4  
 Figure 3.4 Recommended Alternative for Segment B Typical Section .....3-5  
 Figure 3.5 Recommended Alternative for Segment C Typical Section .....3-6

**APPENDICES**

Appendix A - Existing Conditions Data Collection..... A  
 Appendix B - Field Review Notes ..... B  
 Appendix C - Crash Data ..... C  
 Appendix D - Existing Conditions Exhibits ..... D  
 Appendix E - Transit Exhibits ..... E  
 Appendix F - Proposed Alternatives Exhibits ..... F





## Executive Summary

The St. Lucie Transportation Planning Organization (TPO) retained Stanley Consultants, Inc. to complete this feasibility study to evaluate multimodal improvements to the Walton Road corridor from Lennard Road to Indian River Drive. Walton Road is located within the limits of the City of Port St. Lucie and is owned and maintained by St. Lucie County. A demand for multimodal facilities exist in the surrounding study area due to residential and commercial land use, St. Lucie Civic Center, St. Lucie Medical Center, Savannas Preserve State Park, Woodstork Trail, existing off road shared use paths, and the National East Coast Greenway trail.

The recommended improvements are consistent with local transportation plans. The FY 2014/15 – FY 2015/16 Unified Planning Work Program (UPWP) for the St. Lucie TPO includes Task 4.1, Walton Road Multimodal Improvements. Sidewalk improvements to the Walton Road corridor from Lennard Road to SE Green River Parkway were second in the 2014/15 priority ranking, third on the 2015/16 list of priority projects (LOPP), identified as part of the Walk-Bike needs and network improvements, and included in the cost feasible plan for the recently adopted Go2040 St. Lucie TPO Long Range Transportation Plan (LRTP). Completing the missing link of off road shared use path from Lennard Road to SE Green River Parkway was included with the recommended preferred alternative in the Bicycle/Pedestrian Corridor Study Area of Interest Analysis completed by the St. Lucie TPO in 2011.

The entire study corridor spans approximately 1.9 miles with the roadway right of way (ROW) width varying from 50 feet to 150 feet. The study begins at Lennard Road as a four-lane section with bike lanes, sidewalk and off road shared use path for approximately 800 feet and then transitions into a two-lane section with no paved shoulders or bicycle facilities all the way to Indian River Drive at the end of the study. Sidewalks, bike lanes or shared use paths are not present between SE Scenic Park Street and Indian River Drive.

The study corridor was divided into three segments based on existing multimodal facilities, ROW width and recommended alternatives. Segment A is a four-lane divided roadway starting at Lennard Road and terminating 800 feet east of the intersection. This segment currently contains multimodal facilities on both sides of Walton Road and is the only segment with a four-lane typical section with divided median. Segment B is from the end of Segment A to SE Green River Parkway, with varying ROW width. The existing land use is residential, vacant parcel, private hospital to the south, and the Savannas Preserve State Park to the north. Segment C is a two-lane rural roadway from SE Green River Parkway to Indian River Drive. The extents of Segment C were based on the ROW width, guardrail through the Savannas Preserve State Park, and the FEC Railroad crossing.

An evaluation of existing traffic counts and future volumes for Walton Road was completed to determine if roadway widening would be required in the future. Based on the planning tables found in the 2013 Florida Department of Transportation Quality and Level of Service Handbook. Walton Road is expected to have a level of service C thru the year 2040.

The following alternative recommendations were found in this feasibility study:

- **Segment A** – No recommended alternative due to existing acceptable multimodal features.



- **Segment B** – extend sidewalk on north side of Walton Road from SE Scenic Park Street to Green River Parkway, extend shared use path from east of SE Rainer Road to Green River Parkway, add on-street bike lanes in both directions. Minimum ROW width required for this typical section is 65 feet.
- **Segment C** – extend sidewalk on north side of Walton Road from Green River Parkway to Indian River Drive, add on-street bike lanes in both directions. Minimum ROW width required for this typical section is 50 feet. Kayak crossing options were evaluated for this segment in order to improve connectivity from the kayak launch south of Walton Road to the Savannas Preserve State Park to the north.
  - Kayak Crossing Under Walton Road – the option of adding an under road crossing for kayaks and other non-motorized watercrafts through an arch culvert. Raising of Walton Road would be needed to meet vertical clearance.
  - Kayak Crossing Over Walton Road – the option of allowing multimodal water users to cross over Walton Road with a kayak portage was evaluated. The alternative would require a mid-block pedestrian crossing signal and adequate ingress and egress from the waterway.

Currently in Segment B one portion of the ROW is restricted to 50 feet due to Savannas Preserve State Park to the north and a vacant parcel owned by the St. Lucie County School Board. Based on coordination with the St. Lucie County School Board, the Board may be open to donating ROW adjacent to Walton Road to add off road paths or sidewalks. Furthermore, an elevated boardwalk style structure, with a minimum width of 10 feet, with pedestrian railing is recommended between SE Arenson Lane and SE Belcrest Street.

The recommended alternative for Segment C includes on-street bike lanes and sidewalk only on the north side of Walton Road. This recommended alternative could fit in the restricted 50-foot ROW by elevating the north sidewalk on a gravity wall with a pedestrian railing and guardrail on both sides of the roadway. In addition to the roadway improvements, two kayak crossing options were also evaluated.

Estimated costs for the recommended alternatives can be seen in the table. The cost estimation for Segment C does not include FEC railroad crossing improvements. The kayak options are not included in the total cost.

Segment	Total Cost
<b>Segment A</b> (Lennard to 800' E of Lennard)	Maintain existing conditions
<b>Segment B</b> (800' E of Lennard to Green River Parkway)	\$950,000 - \$1,000,000
<b>Segment C</b> (Green River Parkway to Indian River Drive)	\$950,000 - \$1,050,000
<b>Kayak Option Under</b>	\$900,000
<b>Kayak Option Over</b>	\$115,000
<b>Total Cost (Segment A+B+C)</b>	\$1,900,000 - \$2,050,000

These recommended improvements would enhance pedestrian mobility, provide safety benefits to both bicyclists and pedestrians as well as provide potential connections to future trails.



## 1.0 Introduction

The St. Lucie Transportation Planning Organization (TPO) retained Stanley Consultants, Inc. to complete this feasibility study to evaluate multimodal improvements to improve connectivity along the Walton Road corridor from Lennard Road to Indian River Drive. The study corridor spans approximately 1.9 miles, of which 1.5 miles lack any existing pedestrian or bicycle facilities.

This feasibility study is consistent with several TPO transportation plans. It is identified in the adopted Go2040 St. Lucie TPO Long Range Transportation Plan (LRTP) as part of the TPO's Walk-Bike Needs and Network Improvements and Cost Feasible Plan. The FY 2014/15 – FY 2015/16 St. Lucie TPO Unified Planning Work Program (UPWP) includes Walton Road Multimodal Improvements. It is listed as second in the 2014/15 priority ranking and third on the 2015/16 list of priority projects (LOPP) as a Transportation Alternatives (TA) project for adding sidewalks, with project source listed as St. Lucie County School District. Furthermore, completing the missing link of off road shared use path from Lennard Road to SE Green River Parkway was included with the recommended preferred alternative in the Bicycle/Pedestrian Corridor Study Area of Interest Analysis completed by the St. Lucie TPO in 2011.

### 1.1 Study Area

Walton Road from Lennard Road to Indian River Drive is located within the City of Port St. Lucie and is owned and maintained by St. Lucie County. Walton Road is classified as a Minor Arterial Urban. Walton Road provides the only roadway, pedestrian or bicycle link between US 1 and Indian River Drive between Midway Road (6 miles north) and Jensen Beach Blvd (4 miles south).

The study begins at Lennard Road as a four-lane section for approximately 600 feet and transitions into a two-lane section with no paved shoulders or bicycle facilities all the way to Indian River Drive, (the end of the study) with a roadway right of way (ROW) width varying from 50 feet to 150 feet.

The surrounding land use is predominantly residential and includes the Savannas Preserve State Park, a convenience store, churches, a private hospital, vacant school board property, and the Florida East Coast Railway (FECR) crossing at the east end of the project. The St. Lucie County School District owns a vacant property on the southeast corner of Walton Road and SE Belcrest Street. The Port St. Lucie Hospital (private hospital) is located on the southeast corner of Walton Road and SE Grand Drive.

Savannas Preserve State Park entrance is located on Walton Road within the study segment between SE Belcrest Street and SE Grand Drive. This park entrance provides access for hikers and bicyclists. The park contains over eight miles of multi-use trails for hiking, bicycling and horseback riding. The Greater Savanna Preserve Natural Area stretches for more than 10 miles from Ft. Pierce to Jensen Beach and it is the most intact remnant of Florida's east coast savannas.

The overall study area map is shown in **Figure 1.1**. The study corridor has several multimodal trip generators nearby. There is the large residential community, St. Lucie Civic Center, St. Lucie Medical Center, Port St. Lucie High School, Sandhill Crane Park, Wood Stork Trail, Savannas Preserve State Park hiking and kayak trails, Green River Parkway Trail, connections to the beach via Indian River Drive, and the National East Coast Greenway Trail.



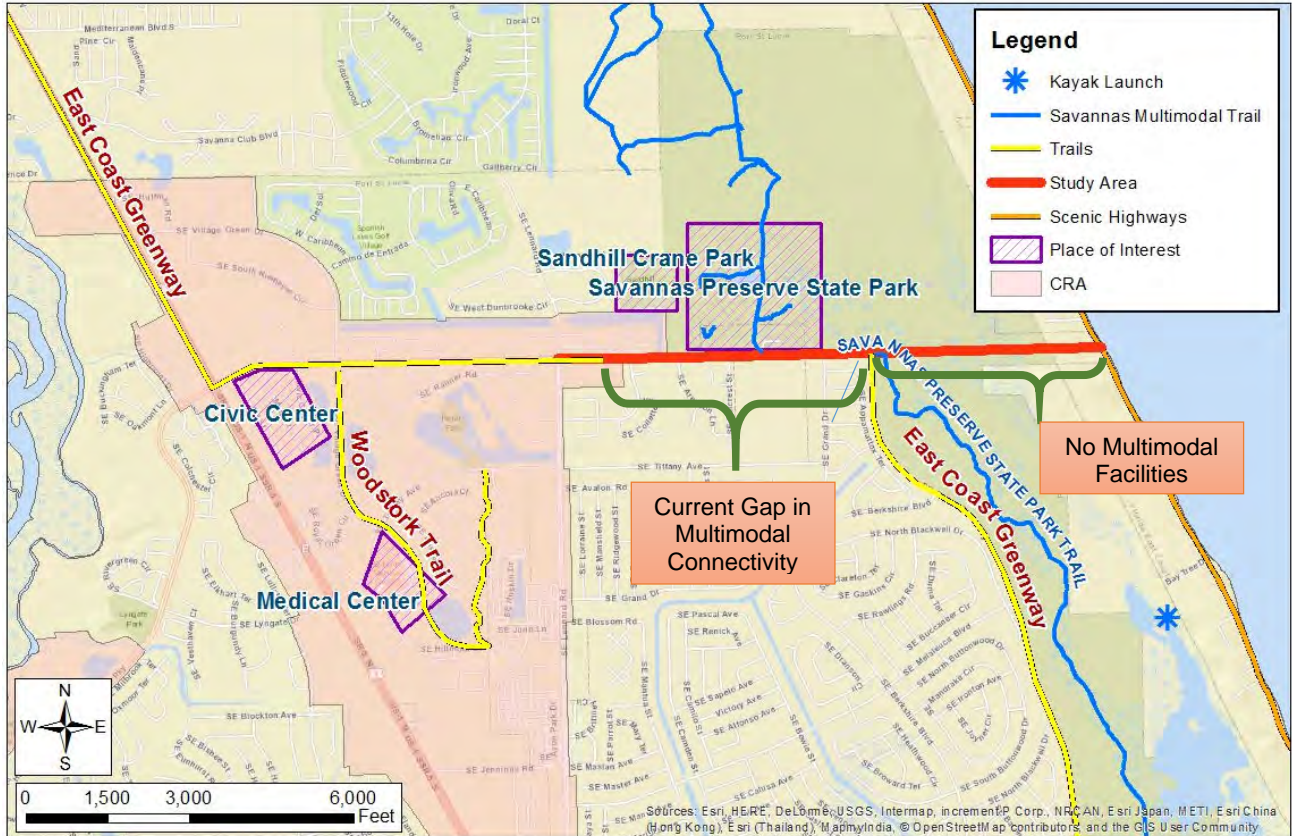

Figure 1.1 Overall Study Area

The National East Coast Greenway Trail is a 3,000-mile trail linking major cities along the Atlantic coastline from Maine to Florida. Within the Walton Road study segment, the East Coast Greenway Trail follows a variety of sidewalks and shared use paths. However, a multimodal gap exists and the national trail must utilize the two-lane rural roadside grass shoulder as the pathway until reaching the south connection that follows the Green River Parkway Trail. This study identifies improvements to complete that gap in the trail and complete other local trail and multimodal network connectivity.

The study corridor was divided into three segments based on the existing conditions and potential alternative solutions. These segments are described below and illustrated in **Figure 1.2**.

- **Segment A:** Begins at the intersection of Lennard Road and extends 800 feet east. This is where the four-lane divided roadway transitions to the two-lane rural section. The existing roadway segment contains multimodal facilities on both sides of Walton Road and is the only segment with a four-lane typical section with divided median.
- **Segment B:** Begins 800 feet east of Lennard Road and ends at SE Green River Parkway. This two-lane rural roadway has a ROW width from 50 ft to 150 ft. The existing roadway segment contains one sidewalk multimodal facility on the north side of Walton Road from the segment beginning to SE Scenic Park Street.



- **Segment C:** Begins at SE Green River Parkway and ends at Indian River Drive. This is a two-lane rural roadway that has a ROW width from 50 ft to 100 ft. The existing roadway segment contains no multimodal facilities.



Figure 1.2 Project Segment Map

## 1.2 Study Purpose and Need

The purpose of this study is to evaluate the feasibility of adding multimodal improvements along the Walton Road corridor between Lennard Road and Indian River Drive to improve multimodal connectivity, pedestrian and bicyclist safety.

There are no existing bike lanes or paved shoulders on the two-lane portion of Walton Road east of Lennard Road to Indian River Drive. Several multimodal trails and pathways end at Walton Road due to the lack of multimodal facilities. Regional vehicles and multimodal users must share the roadway travel lanes or roadside within the two-lane rural section. The roadside through the Savanna Preserve State Park is elevated low, often wet and bounded by guardrail.

An existing twelve foot wide off-road shared use path begins west of the study corridor at US-1 and meanders along the south side of Walton Road stopping at the driveway access to Highpoint Community Church between Lennard Road and SE Rainer Road. **Figure 1.3** shows the end of the path within the study corridor on the east side of the Highpoint Community Church driveway. A need exists to connect this shared use path with the paved trail at the southeast corner of Walton Road and SE Green River Parkway. This connection would provide a cohesive, safe facility for the East Coast Greenway.



Figure 1.3 End of Shared Use Path





According to the East Coast Greenway website, the section of the trail on Walton Road from Lennard Road to SE Green River Parkway is showing as “on-road routing” until it joins the Green River Parkway Trail. **Figure 1.4** shows the Green River Parkway Trail termini at Walton Road. A screenshot from the website showing the East Coast Greenway trail through the study corridor can be seen in **Appendix D**.



**Figure 1.4 End of Green River Parkway Trail**

Within the study corridor an existing six-foot wide sidewalk, shown in **Figure 1.5**, is located on the north side of Walton Road from Lennard Road to SE Scenic Park Street leading north to Sandhill Crane Park which is owned by the City of Port St. Lucie. There is a need to continue the sidewalk east to the Savannas Preserve State Park entrance and also provide a safe pedestrian connection to the existing paved Green River Parkway Trail.



**Figure 1.5 Sidewalk on North**

Walton Road crosses the Savannas Preserve State Park Multimodal Trail, designated for non-motorized recreational water craft. There is a kayak launch located south of the study area off of Riverview Drive, west of the FEC railroad. The kayak trail has a gap at Walton Road due to the lack of an over-the-road kayak portage or an under-the-road kayak culvert crossing. This multimodal feasibility study evaluates kayak alternatives in **Section 3.7** in order to improve connectivity of the kayak launch across Walton Road.





## 2.0 Existing Conditions Analysis

### 2.1 Physical

Assessing existing conditions along the corridor included data collection and analysis, office and field reviews and documenting deficiencies. Plans were requested and received from St. Lucie County Engineering Division for the Walton Road Widening (County Project No. 05-51) showing the typical section, sidewalk details and improvements east of Lennard Road. A field review was conducted on Thursday, March 24, 2016 to document existing conditions, identify deficiencies and verify information from the office review.

The existing ROW width varies along the Walton Road from 50 feet to 150 feet. Between Lennard Road and SE Scenic Park Street the existing ROW width is 150 feet and narrows to 100 feet just east of SE Belcrest Street. Adjacent to the parcel owned by St. Lucie County School District and the Savannahs Preserve State Park the existing ROW width is 50 feet and widens to 65 feet adjacent to Port St. Lucie Hospital, Inc. The existing ROW width is 80 feet west of SE Grand Drive to east of SE Green River Parkway and narrows to 50 feet through the Savannahs Preserve State Park. The existing ROW width is 100 feet from the FEC railroad crossing to Indian River Drive. The variation of ROW can be seen on next page in **Figure 2.1**.

An existing raised median on Walton Road was present only within the four-lane section east of Lennard Road. The existing off-road shared use path on the south side was in very good condition. Existing six foot wide concrete sidewalk along the north side spanned from the beginning of the project at Lennard Road to SE Scenic Park Street and was found to be in good condition.

In the two-lane section existing travel lanes were measured and found to be 11 feet wide with a total paved roadway width of 22 feet. The pavement condition for the two-lane section (Segment B & C) was found to be in excellent condition based on a full depth resurfacing of the existing asphalt completed as a maintenance project by St. Lucie County in 2015.

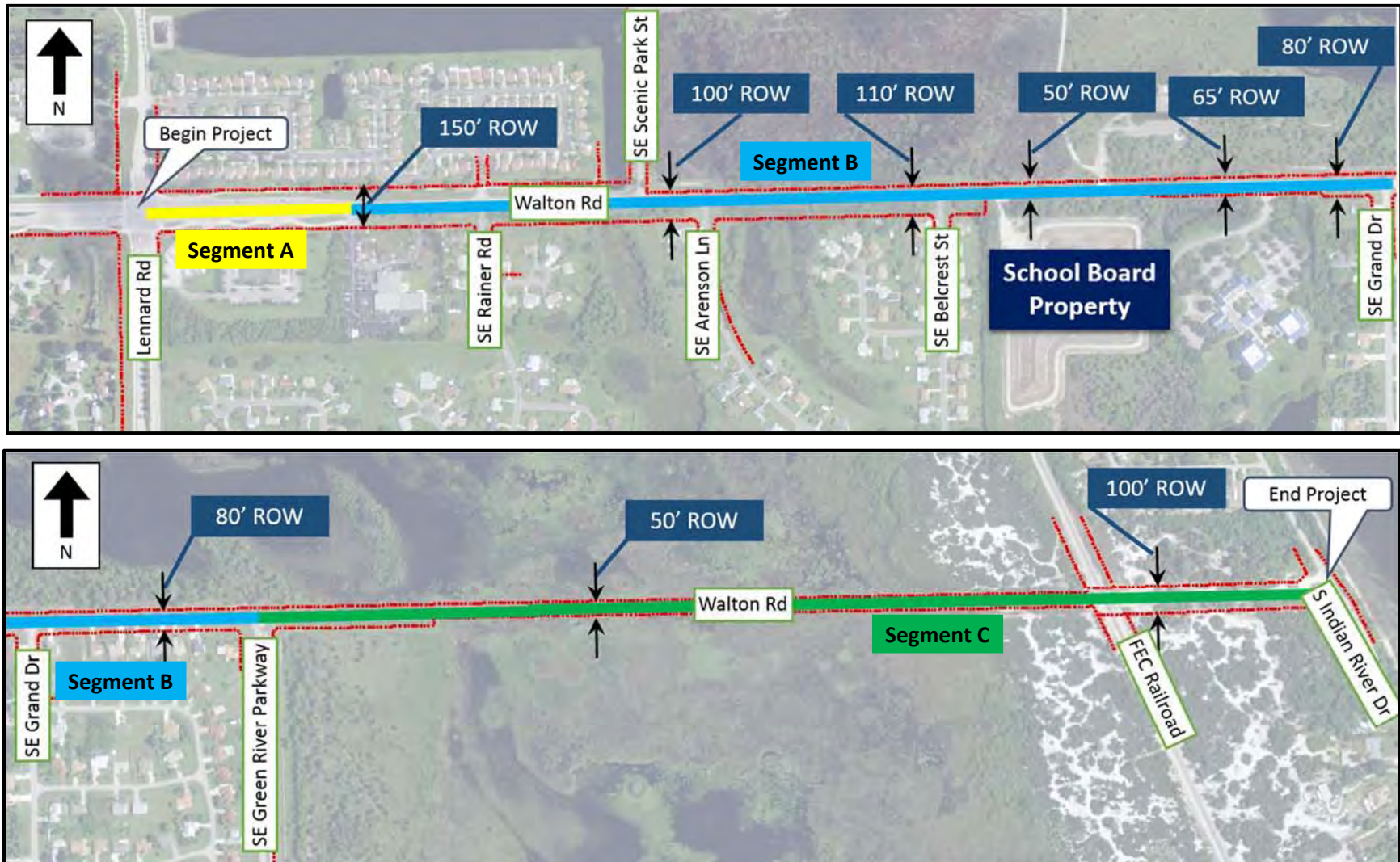

Figure 2.1 Existing Right Of Way





Information was provided by St. Lucie County Public Works Department (SLCPWD) showing the approximate location of two 48" x 60' RCP and two 72" x 60' CPM culverts east of Green River Parkway. The approximate culvert locations can be seen in the existing conditions map found in **Appendix D** based on a hand sketch provided from St. Lucie County. Additional information provided by SLCPWD verified that a permit was issued by the United States Army Corps of Engineers for the cleaning and restoration of the existing pipes and the work was completed in 1999. Existing cross culverts under Walton Road east of SE Green River Parkway for hydraulic connectivity of wetland areas were not visually located and could not be verified during the field review. Due to the lack of information and maintenance, it is recommended to evaluate the existing culverts.



**Figure 2.3 Damaged Guardrail**



**Figure 2.4 Intersection Lighting**

Street lighting in Segment A was located along the north and south side east of Lennard Road and terminated where the roadway transitions from four lanes to two lanes, approximately 800 feet east of the intersection. Intersection lighting was located at the following intersection locations along the study corridor: the northeast corner of SE Scenic Park Street, the southwest corner of SE Grand Drive, and the southwest corner of SE Green River Parkway. A photo of intersection lighting on a single pole can be seen in **Figure 2.4**. Existing overhead utilities were present along the south side of Walton Road and appeared to be within the 20-foot utility easement located adjacent to the existing ROW line shown on the widening plans provided from St. Lucie County. The existing overhead utility lines located on the south side stopped east of SE Green River Parkway continuing underground to just west of the FEC Railroad crossing and then continued overhead to Indian River Drive. **Appendix D** provides a detailed map of noted existing conditions found for this study.

No transit stops are currently located within the study corridor, nor do any transit routes pass through the corridor. An exhibit showing nearby transit stops and routes can be found in **Appendix E**.



## 2.2 Operation

Evaluation of the average vehicle speed was completed based on speed data collected at three locations along the corridor on Thursday March 17, 2016. The posted speed on the study corridor is 45 mph and a posted speed limit sign can be seen in **Figure 2.5**. The results from the data collected east of Lennard Road, as well as east and west of SE Green River Parkway indicate the 85th percentile speed is 43 MPH. The posted speed for Walton Road is 45 MPH. The collected speed data can be found in **Appendix A**.

Field observations confirmed that roadway operating conditions along the corridor and the stop controlled intersections are satisfactory. All stop controlled intersections within the study corridor were observed to operate at an acceptable level of service for vehicles. Several bicyclists were observed sharing the roadway with vehicles.



**Figure 2.5 Speed Limit Sign**

The current access control is limited to a raised median within the four-lane section east of Lennard Road as well as right and left turn lanes at SE Powderly Place/SE Rainer Road intersection, SE Scenic Park Street and the driveway access to Port St. Lucie Hospital west of SE Grand Drive.

## 2.3 Safety

A review of crash data received from TPO staff for the most recent 5-year period from 2011-2015 was performed to evaluate safety conditions along the corridor within the study limits.

**Table 2.1 Crash Distribution by Year**

Year	Number of Crashes
2011	3
2012	2
2013	2
2014	9
2015	12
<b>Total Crashes</b>	<b>28</b>

A total of 28 crashes occurred within the study limits from 2011 to 2015 and is represented in **Table 2.1**. A significant increase in crashes is apparent between year 2013 and 2014. The largest number of crashes reported for year 2015 with twelve crashes, followed by 2014 with nine crashes. A more detailed crash analysis was completed for 2014 and 2015 due to the large increase of crashes and is presented later in this section.



The crash distribution by location was also analyzed and can be seen in **Figure 2.6**. The intersection with the most amount of crash incidents for the study corridor during the five year period was Lennard Road with nine crashes, followed by Indian River Drive with eight crashes. Seven out of the nine crashes that occurred at Lennard Road were “rear end” crashes, with one crash reported as “other” and one “bicycle” crash. The large number of “rear end” crashes at this intersection could be due to congestion at the intersection signal. Three “rear end”, three “run off” road, and two “other” crashes make up the eight collisions reported for the Indian River Drive intersection. At SE Green River Parkway four out of five of the collisions were “left turn” crashes and one was an “off road” crash. No “pedestrian” collisions were reported for the study corridor. The crash data can be found in **Appendix C**.

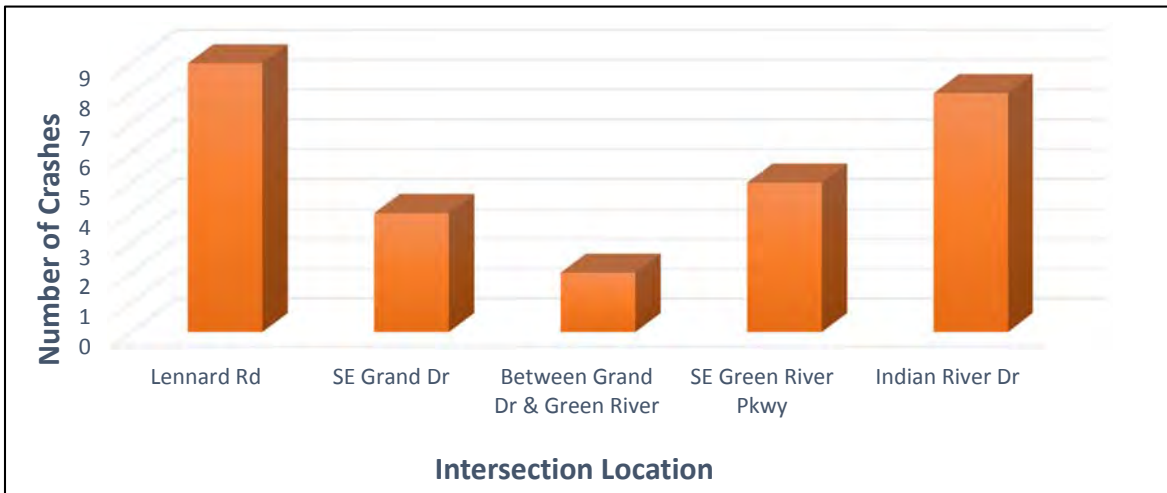

**Figure 2.6 Five Year Crash Distribution by Intersection Location**

**Table 2.2** shows that the majority of crashes occurred during clear conditions. The study corridor does not have a pattern of crashes occurring in wet/rainy conditions.

**Table 2.2 Crash Distribution by Weather Condition**

Weather Condition	Number of Crashes
Clear	24
Cloudy	1
Rain	2
Fog, Smog, Smoke	1

The majority of crashes occurred in the daylight condition, as shown in **Table 2.3**. Only four crashes were reported in dark, unlit conditions and one dark crash did not report the lighting condition. Including the unknown lighting crash the percentage of crashes that occurred in dark conditions for the study area is 18%.



**Table 2.3 Crash Distribution by Lighting Condition**

Lighting Condition	Number of Crashes
Daylight	19
Dawn/Dusk	2
Dark - Lighted	2
Dark - Not Lighted	4
Dark - Unknown Lighting	1

**Table 2.4** illustrates that Rear End collisions account for largest percentage of collision type for the study corridor with 12 crashes and 43%. The next major collision type is Off-Road with 6 crashes and 21%. Left Turn crashes was the third most reported collision type with 14% of the crashes within the study corridor. There was one reported bicycle crash that occurred at Lennard Road.

**Table 2.4 Crash Distribution by Collision Type**

Collision Type	Number of Crashes
Rear End	12
Left Turn	4
Off-Road	6
Bicycle	1
Other	5

Further analysis was completed to evaluate the large increase of crashes from 2013 to 2014 and from 2014 to 2013. **Table 2.5** and **Table 2.6** illustrate the detail analysis completed for the year 2014 by crash location and crash type.

**Table 2.5 Location Distribution Year 2014**

Intersection Location	Number of Crashes
Lennard Road	3
SE Grand Drive	1
Between Grand Drive & Green River	0
SE Green River Pkwy	2
Indian River Drive	3

**Table 2.6 Crash Type for Year 2014**

Collision Type	Number of Crashes
Rear End	3
Left Turn	2
Off Road	3
Bicycle	0
Other	1





All the crashes for 2014 were analyzed by location and crash type in order to determine if a pattern exists to explain the jump from two crashes in 2013 to nine crashes in 2014. Lennard Road and Indian River Drive were reported to have three crashes each. The most common crash type for 2014 was rear end crashes and 3 off road crashes. The three crashes that occurred at Lennard Road were two rear end crashes and one other crash. The three crashes that occurred at Indian River Drive consisted of one rear end crash and two off road crashes.

Further detailed crash analysis was also completed for year 2015 and can be seen in **Table 2.7** and **Table 2.8**.

**Table 2.7 Location Distribution for Year 2015**

Intersection Location	Number of Crashes
Lennard Road	5
SE Grand Drive	0
Between Grand Drive & Green River	2
SE Green River Pkwy	1
Indian River Drive	4

**Table 2.8 Crash Type for Year 2015**

Collision Type	Number of Crashes
Rear End	7
Left Turn	0
Off Road	2
Bicycle	0
Other	3

It can be seen in **Table 2.7** that for the year 2015 five crashes occurred at the intersection of Lennard Road. Further analysis revealed that all five of those crashes are rear end crashes. Out of the four crashes that occurred at Indian River Drive, two were rear end crashes and two were other crashes.

From conducting additional analysis for 2014 and 2015 it can be concluded that more crashes were occurring on Walton Road at the intersections of Lennard Road and Indian River Drive. The amount of rear end crashes are also increasing.

## 2.4 Traffic

Existing traffic volume data was collected on March 17, 2016 at three locations along the corridor. The average daily traffic (ADT) for the location east of Lennard Road is 9,997 vehicles per day. The location west of Green River Parkway has an ADT of 8,625 vehicles per day and east of SE Green River Parkway the ADT is 6,285. The daily traffic volumes from the count data appear to be consistent when compared to the annual average daily traffic (AADT) shown in the St. Lucie County TPO Traffic Counts and Level of Service Report Fall 2015. The AADT from Lennard Road to SE Green River Parkway was shown to be 9,600 and from SE Green River Parkway to Indian River Drive it was 5,700.



Based on the 2016 ADT, the roadway is operating at an acceptable level of service (LOS) C for a two-lane undivided urban minor arterial.

Future volumes were provided for Walton Road from the consultant for the TPO working on the Go2040 LRTP. The 2040 future volumes are from the TCRPM 4 model and were still under review but used for the adopted 2040 Cost Feasible alternative analysis for the LRTP update. These future volumes and the St. Lucie County TPO 2015 AADT are represented in **Table 2.9**.

**Table 2.9 Traffic Volumes and LOS for Walton Road**

Walton Road Section	2015 AADT	2040 Volumes	Future LOS
Lennard Road to Green River Pkwy	9,600	12,480	C
Green River Pkwy to Indian River Drive	5,700	9,600	C

A preliminary LOS analysis was completed for the expected future year volumes of 2040 using the Florida Department of Transportation Generalized Level of Service tables from the most recent (2013) Quality/Level of Service Handbook. For an urban undivided two lane roadway section with a mph greater than 40, the LOS AADT volume threshold is 15,120. This volume accounts for the roadway being a non-state signaled roadway. For both roadway sections the predicted future 2040 volume meets the threshold for a two-lane undivided roadway and the need for capacity improvements are not expected.









## 2.6 Deficiencies

During the office and field review the study corridor was analyzed to determine multimodal deficiencies including missing bicycle and pedestrian facilities, lighting, paved shoulders and signage. The following deficiencies were noted:

- There are no paved shoulders on the two-lane section east of Lennard Road to the study limits at Indian River Drive as shown in **Figure 2.10**.
- The only pedestrian crossings within the corridor are located at Lennard Road.
- There is no existing sidewalk on the north side of Walton Road east of SE Scenic Park Street and no sidewalk on the south side beyond the existing off-road shared use path ending west of SE Rainer Road.
- There is no street lighting along Walton Road on the two-lane section east of Lennard Road to Indian River Drive except at the SE Scenic Park Street and SE Green River Parkway intersections.



**Figure 2.10 Walton Road Two-Lane Section**



### 3.0 Alternatives Evaluation

Existing multimodal facilities consisting of on-street bike lanes, off road shared use path and sidewalk are located within Segment A; therefore, no alternatives are presented for this study corridor segment. Alternatives for adding multimodal improvements in Segment B and C were evaluated based on a planning level analysis with respect to available right of way, connectivity to existing bicycle and pedestrian facilities, environmental and social-cultural factors as well as feasibility of implementation. Increasing mobility and improving safety for both bicycles and pedestrians by enhancing or expanding existing facilities was part of the evaluation process. There are no existing multimodal facilities on Indian River Drive. Multimodal improvements to Indian River Drive would require a separate study.

As stated in **Section 2.4**, the existing 2016 traffic volumes on Walton Road show that the two-lane section is operating at an acceptable LOS and projected 2040 traffic volumes indicate widening of the roadway is not expected to be needed to meet future capacity requirements. Therefore, roadway capacity improvements were not evaluated for this study. Two roadway alternatives are presented in this section, one for Segment B and one for Segment C. A summary of the recommended alternatives discussed in this section are presented in **Table 3.1**.

**Table 3.1 Summary of Recommended Alternatives**

Segment	Recommended Alternative
Segment A	Maintain existing multimodal features
Segment B	Bike lanes, sidewalk, multiuse path
Segment C	Bike lanes, sidewalk

#### 3.1 Bike Lanes and Paved Shoulders

Adding on-street bike lanes or paved shoulders to the two-lane section in Segments B and C was evaluated based on increasing safety within the corridor and increasing bicycle mobility to existing surrounding bike paths. A four foot bike lane is the minimum functional width for a roadway without curb and gutter and flush shoulders per Chapter 9 of the Florida Green Book. In addition, paved shoulders four feet or wider may be marked as bicycle lanes and considered to be bicycle facilities.

Bicycle counts were taken during the AM and PM peak period on a weekday and also during the midday period on a weekend to evaluate existing bicycle usage along the corridor. The count data at the Lennard Road intersection indicated a low number of riders using the roadway but some bicyclists were observed riding on the existing off road shared use path. Data from the counts at the Green River Parkway intersection also showed a low number of riders overall with the largest number of bicyclists south of the intersection utilizing the shared use path. However, some bicyclists were observed riding east of Green River Parkway on Walton Road towards Indian River Drive reassessing the need of bike lanes for safety along this portion of roadway. The collected bicycle count data can be found in **Appendix A**.

There are two sections within the study corridor with existing ROW widths of 50 feet. One section is located east of SE Belcrest Street spanning the current vacant school board parcel and the other





section is located from east of SE Green River Parkway to west of the FEC Railroad. A photo of the two-lane section with an existing 50 foot ROW width east of SE Green River Parkway is shown in **Figure 3.1**. Both of these sections can accommodate bicycle and pedestrian facilities within the existing ROW width, therefore, adding four foot wide bike lanes in each direction is feasible for both Segment B and C.

The cost for bike lane improvements was estimated using the FDOT Long Range Estimation System for milling and resurfacing a two-lane rural road with five-foot paved shoulders and will be included for the overall cost estimate for each alternative presented later in this section. A typical section diagram showing how bicycle lanes can be accommodated within the existing ROW width is also presented later in this section.



**Figure 3.1 Two Lane Section from Segment C**

### 3.2 Sidewalks

Adding missing sidewalks and connecting residential areas to the Savannas Preserve State Park as well as increasing pedestrian access, safety and enhancing mobility was evaluated for the entire corridor.

Pedestrian counts were taken during the AM and PM peak period on a weekday and also during the midday period on a weekend to evaluate existing pedestrian usage along the corridor. The count data at the Lennard Road intersection showed no pedestrians using the sidewalk on the north side of Walton Road but some pedestrians were observed walking on the shared use path. During the field review one pedestrian was observed walking along the south side of Walton Road between SE Arenson Lane and SE Scenic Park Street as shown in **Figure 3.2**.



**Figure 3.2 Pedestrian Walking Along Walton Road**



Data from the count at the Green River Parkway intersection also revealed a low number of pedestrians overall and all observed pedestrians were using the existing paved trail on the east side of SE Green River Parkway south of Walton Road. The collected pedestrian count data can be found in **Appendix A**.

Adding six-foot wide sidewalk on the north side of Walton Road in Segment B between SE Scenic Park Street and SE Green River Parkway and in Segment C from SE Green River Parkway to Indian River Drive is feasible. In Segment C, there is possibility of portions of the recommended sidewalk traversing existing wetland areas requiring fill, gravity walls and lateral offsets to minimize impacts to environmentally sensitive areas. However, impacts to wetlands located in existing roadside swales within the ROW typically do not require mitigation. It is recommended that the quality of delineated wetland areas be evaluated during the design and permitting phases to make a determination of potential impacts and costs.

The estimated cost associated with only the sidewalk improvements is shown in **Table 3.2**. A typical section diagram showing how sidewalks can be accommodated within the existing ROW width is presented in **Figure 3.4** and **Figure 3.5**.

**Table 3.2 Sidewalk Estimated Cost per Study Section**

Segment	Sidewalk Cost
<b>Segment A</b> (Lennard to 800' E of Lennard)	N/A
<b>Segment B</b> (800' E of Lennard to Green River Parkway)	\$80,000
<b>Segment C</b> (Green River Parkway to Indian River Drive)	\$89,000
<b>Total</b>	\$169,00

### 3.3 Shared Use Path

Continuing the existing off-road shared use path on the south side of Walton Road in Segment B to the shared use path east of Green River Parkway was evaluated based on increasing both bicycle and pedestrian mobility for all users. Based on the Bicycle/Pedestrian Corridor Study Area of Interest Analysis completed by the St. Lucie TPO in November 2011, continuing the existing off-road path east of Lennard Road to the existing Green River Trail was included as part of the recommended preferred alternative. In addition to recommendations from previously completed studies, counts taken at both the Lennard Road and Green River Parkway intersections, documented that there is some current usage of the existing off road path and paved trail by both bicyclists and pedestrians. The collected bicycle and pedestrian count data can be found in **Appendix A**.

The two-lane section of Walton Road in Segment B from west of SE Rainer Road up to SE Arenson Lane has ROW widths varying from 100 to 150 feet. Continuing the meandering 12-foot wide off-road path between the existing edge of pavement and 20-foot wide utility easement adjacent to the south ROW line is feasible. However, minimal clearing and grubbing and some added fill will be necessary along this segment. Furthermore, there are some wetlands located within this segment. An elevated



boardwalk style structure with pedestrian railing at a minimum of 10 feet wide would be the preferred type of improvement due to less impacts than an at-grade paved path.

The segment east of SE Belcrest Street adjacent to the parcel owned the St. Lucie County School District has an existing ROW width of 50 feet. Continuation of the 12' wide meandering off road shared use path along the south side in addition to on-street bikes lanes and sidewalk on the north side is not feasible within the existing ROW. Based on coordination with St. Lucie Public Schools, the property owned by the school district adjacent to Walton Road could be donated for ROW to add off-road paths or sidewalks.

The estimated cost associated with only the shared use path improvements is shown in **Table 3.3**. A typical section showing the shared use path improvements can be seen in **Figure 3.4** and **Figure 3.5**.

**Table 3.3 Shared Use Path Estimated Cost per Study Section**

Segment	Shared Use Path Cost
<b>Segment A</b> (Lennard to 800' E of Lennard)	N/A
<b>Segment B</b> (800' E of Lennard to Green River Parkway)	\$213,000
<b>Segment C</b> (Green River Parkway to Indian River Drive)	N/A
<b>Total</b>	\$213,000

### 3.4 Pedestrian Crossings

Pedestrian crossings at the SE Belcrest Street and SE Green River Parkway intersections are recommended for better connectivity from residential areas along the south side of Walton Road to Sandhill Crane Park and Savannahs Preserve State Park located on the north side of Walton Road. **Figure 3.3** shows an example of a proposed pedestrian crossing conditions following Florida Green Book standards.

Cross walk markings with a minimum of a Pedestrian Warning Sign (W11-2) and diagonal downward pointing arrow (W16-7P) plaque together with a roadside flashing beacon assembly or rectangular rapid flashing beacon would be a benefit to pedestrian safety and enhanced visibility by motorists. Additionally, a Pedestrian Warning Sign (W11-2) and supplemental ahead (W16-15P) plaque are also



**Figure 3.3 Example of Pedestrian Crossing on Green River Parkway**



recommended in advance of all cross walk markings as an added safety benefit. The location of these recommended improvements can be found in **Appendix F**.

### 3.5 Recommended Alternatives

There are two recommended alternatives presented in this study for the Walton Road corridor from Lennard Road to Indian River Drive. No multimodal improvements for Segment A, that spans from the begin study limit to 800 feet east of Lennard Road, were recommended due to existing conditions providing adequate multimodal features.

The typical section for the alternative recommended for Segment B can be seen in **Figure 3.4**. In Segment B; bicycle lanes are recommended for both travel directions on four-foot paved shoulders with sufficient pavement markings and signs. The shared use path is recommended to extend from 800 feet east of Lennard Road on the south side of Walton Road to connect with the shared use path east of Green River Parkway providing off road connectivity for the East Coast Greenway. The sidewalk on the north side of Walton Road is recommended to extend from SE Scenic Park Street to Green River Parkway. The minimum ROW requirement for this typical section is expected to be 65 feet with 11-foot roadway widths, four-foot bike lanes, five to six-foot sidewalk, and 10 to 12-foot shared use path.

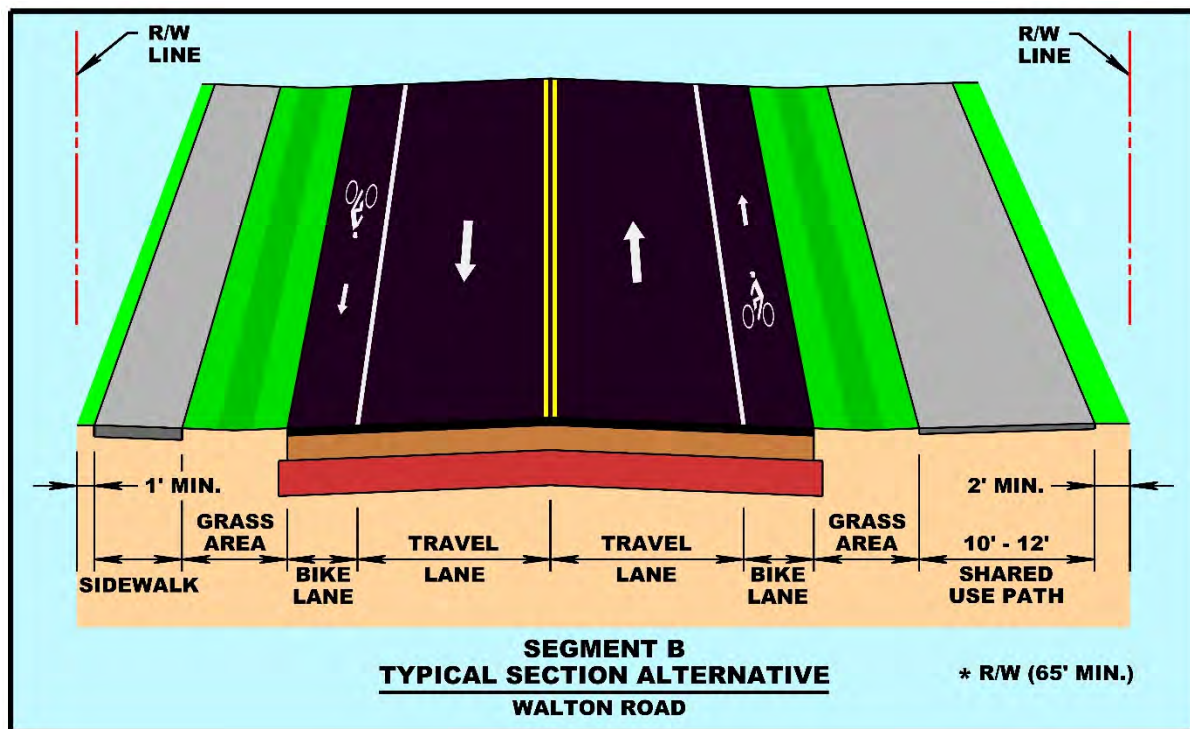
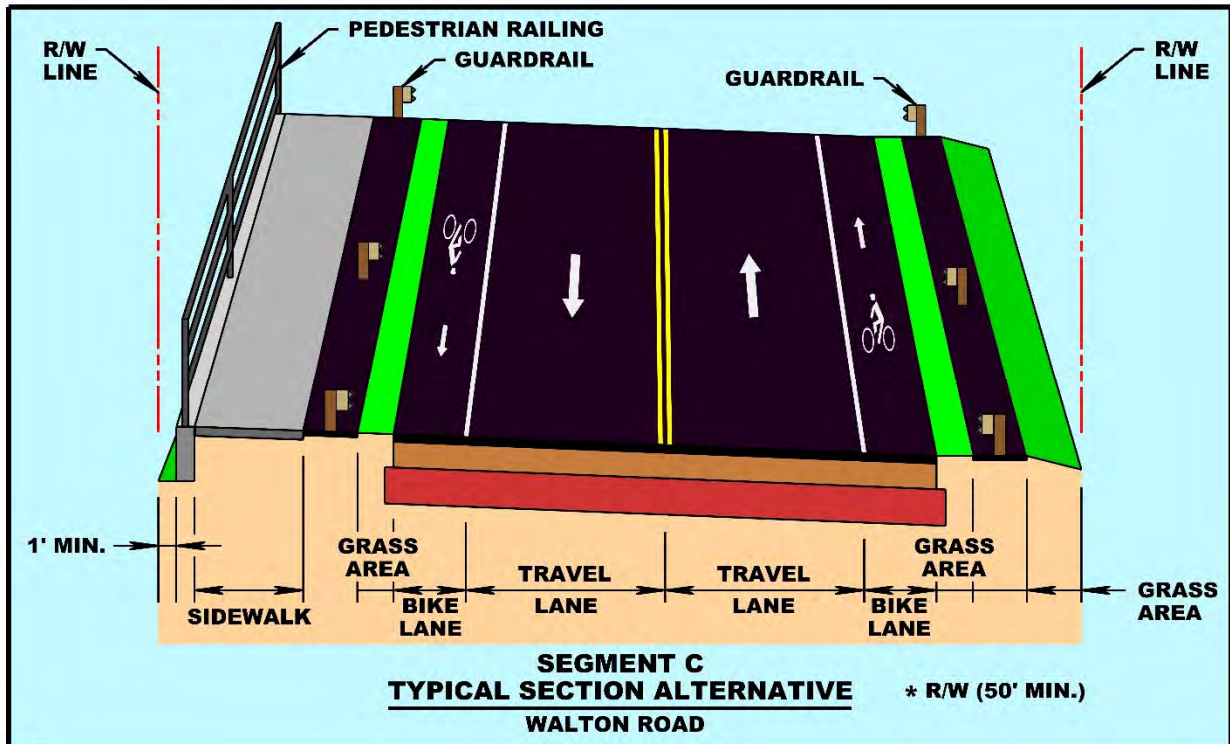

**Figure 3.4 Recommended Alternative for Segment B Typical Section**





The typical section for the alternative recommended for Segment C can be seen in **Figure 3.5**. In Segment C; bicycle lanes are recommended for both travel directions on four-foot paved shoulders with sufficient pavement markings and signs, sidewalk on the north side of Walton Road is recommended to extend to Indian River Drive on gravity wall with a pedestrian railing and separated from the bike lane with a two-foot shoulder and three-foot guardrail, and a guardrail is recommended on the south side due to insufficient clear zone width within the restricted 50 feet ROW. The minimum ROW requirement for this typical section is expected to be 50 feet, reducing impacts to surrounding wetlands and State Park with 11-foot roadway widths, four-foot bike lanes and five to six-foot sidewalk.



**Figure 3.5 Recommended Alternative for Segment C Typical Section**

### 3.6 Total Alternative Costs

As stated in Section 3.1 the cost for adding bicycle lanes was estimated using the FDOT Long Range Estimation System for milling and resurfacing a two-lane rural road with five-foot paved shoulders. This estimated cost is provided by the FDOT per mile of roadway and can be seen in **Appendix F**. The estimated cost for milling and resurfacing the two-lane roadway as well as the addition for bicycle lanes for each study segment can be seen in **Table 3.4**.





**Table 3.4 Estimated Roadway and Bike Lane Cost**

Segment	Milling and Resurfacing with Bike Lanes
<b>Segment A</b> (Lennard Rd to 800' E of Lennard)	N/A
<b>Segment B</b> (800' E of Lennard Rd to Green River Parkway)	\$392,000
<b>Segment C</b> (Green River Parkway to Indian River Drive)	\$341,000
<b>Total</b>	\$733,000

A total of each multimodal improvement estimated cost per each study section can be seen in **Table 3.5**. The cost estimation for Segment C does not include FEC railroad crossing improvements.

**Table 3.5 Total Alternative Cost Estimate**

Segment	Total Cost
<b>Segment A</b> (Lennard to 800' E of Lennard)	N/A
<b>Segment B</b> (800' E of Lennard to Green River Parkway)	\$950,000 - \$1,000,000
<b>Segment C</b> (Green River Parkway to Indian River Drive)	\$950,000 - \$1,050,000
<b>Total</b>	\$1,900,000 - \$2,050,000

### 3.7 Other Multimodal Alternatives

Other multimodal alternatives were considered for this feasibility study due to the expressed intent of the St. Lucie TPO to improve connectivity of the kayak launch located south of the study area to the area of Savannas Preserve State Park north of Walton Road. Currently Walton Road divides the multimodal trail of Savannas Preserve State Park. Two options were evaluated and presented in the following sub sections.

#### 3.7.1 Crossing Under Walton Road Option

Currently there are four culverts located under Walton Road in Segment C. It could be considered to replace one these culverts with an arch culvert large enough to accommodate multimodal users in the savannas to gain access and connectivity within the park. The arch culvert would need to be placed on adequate foundations, roadway embankment will be needed for the roadway to pass over the culvert, MSE wall to retain the embankment in minimal ROW conditions, and have a five-foot minimum required vertical clearance between the low member and the design high water table elevation. Other considerations for the culvert include enough natural daylight passing through the 50 foot long section for safety and user encouragement. A rough estimate for this option is approximately \$900,000.



### **3.7.2 Crossing Over Walton Road Option**

Another option that could be considered in order to improve the connectivity of Savannas Preserve State Park for multimodal water users is a kayak/canoe portage where users would carry their non-motorized watercraft over Walton Road. Adequate ingress and egress structures or embankment would be needed for all users to be able to access the portage and a mid-block pedestrian crosswalk with a button control signal would need to be provided. A rough estimate for this option is approximately \$115,000.



## 4.0 Conclusions and Recommendations

### 4.1 Conclusions

Based on data collected and information received during the office and field reviews, an analysis of the Walton Road corridor existing conditions showed there are deficiencies with bicycle, pedestrian and transit facilities as well as street lighting. For the purpose of this report the corridor was divided into three segments as seen in **Table 4.1**.

**Table 4.1 Study Corridor Segment Description**

Segment Name	Description
<b>Segment A</b>	Lennard Road to 800' east of Lennard Road
<b>Segment B</b>	800' east of Lennard Road to Green River Parkway
<b>Segment C</b>	Green River Parkway to Indian River Drive

Deficiencies found within the study corridor include: no bike lanes or paved shoulders in Segment B and C, sidewalk missing in Segment B and C, no pedestrian access to Savannahs Preserve State Park in Segment B, and a gap in the existing off-road shared use path on the south side of Walton Road to Green River Parkway for the East Coast Greenway. The existing roadway physical and operating conditions were documented and Walton Road has excess capacity based on existing and projected traffic volumes, and an 85<sup>th</sup> percentile speed of 43 MPH which is below the posted speed of 45 mph. The evaluation found that there is sufficient ROW width for incorporating recommended multimodal improvements except for the property owned by the school board.

Field observations confirmed that the roadway operating conditions along the corridor and the stop controlled intersections are satisfactory. According to the field review all intersections within the study corridor appeared to operate at an acceptable level of service for vehicles. Several bicyclist and pedestrians were observed sharing the roadway. A review of crash data received from TPO staff for the most recent 5-year period from 2011-2015, found a total of 28 crashes occurred within the study limits. No “pedestrian” collisions were reported and one “bicycle” crash occurred within the study corridor at the intersection of Lennard Road. However, there is a need for multimodal improvements within the corridor to enhance mobility, connect existing shared use paths, and provide pedestrian access to Savannahs Preserve State Park.

Consistency plan research for the Walton Road segment from Lennard Road to SE Green River Parkway found it was second in the 2014/15 priority ranking and third on the 2015/16 list of priority projects (LOPP) as a Transportation Alternatives (TA) project for adding sidewalks. The project source is listed as St. Lucie County School District. The study corridor was also identified in the recently adopted Go2040 St. Lucie TPO Long Range Transportation Plan (LRTP) as part of the County’s Walk-Bike Needs and Network Improvements and Cost Feasible Plan. Furthermore, completing the missing link of off-road shared use path from Lennard Road to SE Green River Parkway was included with the recommended preferred alternative in the Bicycle/Pedestrian Corridor Study Area of Interest Analysis completed by the St. Lucie TPO in 2011.



Based on the evaluation of alternatives, adding on-street bike lanes, sidewalk on the north side and completing the missing link of off-road shared use path between Lennard Road and SE Green River Parkway is feasible for Segment B. Both on-street bike lanes and sidewalk on the north side are also feasible based on the existing 50 to 100 feet ROW width between SE Green River Parkway and Indian River Drive within Segment C. These improvements would provide safety benefits to both bicyclists and pedestrians as well as potential connections to future trails.

#### 4.2 Recommendations

There are two recommended alternatives presented in this study for the Walton Road corridor from Lennard Road to Indian River Drive. A summary of these alternative can be seen in **Table 4.2** below.

**Table 4.2 Recommended Study Alternatives**

Segment	Recommended Alternative
<b>Segment A</b>	Maintain existing multimodal facilities
<b>Segment B</b>	Bike lanes, sidewalk, multiuse path
<b>Segment C</b>	Bike lanes, sidewalk

Adding a minimum four-foot wide bike lane to each side of the roadway for the two-lane section within Segment B and C is recommended. The two areas with existing ROW widths of 50 feet (east of SE Belcrest Street and east of Green River Parkway) should have sidewalks for pedestrians in addition to on-street facilities for bicycles. Based on coordination with St. Lucie Public Schools, property owned by the school district adjacent to Walton Road could be donated for ROW to add off road paths or sidewalks. Further discussions with St. Lucie Public Schools are recommended.

Adding a six-foot wide sidewalk on the north side of Walton Road east of SE Scenic Park Street to Green River Parkway in Segment B and continuing east to Indian River Drive in Segment C is recommended to enhance pedestrian mobility by increasing access to existing parks and trails.

Continuing the meandering 12-foot wide off-road paved path between the existing edge of pavement and 20-foot wide utility easement adjacent to the south ROW line from west of SE Rainer Road to east of SE Arenson Lane and west of SE Grand Drive to Green River Parkway is recommended. Minimal clearing and grubbing and fill will be necessary along this segment. An elevated boardwalk style structure, a minimum of 10 feet wide, with pedestrian railing is recommended between SE Arenson Lane and SE Belcrest Street.

An exhibit of these proposed recommendations as well as cost estimation can be found in **Appendix F**.



## Appendix A

### Existing Conditions Data Collection

- **Traffic Counts**
- **Speed Data**
- **Pedestrian and Bicycle Counts**
- **FDOT Level Of Service Tables**
- **East Coast Greenway Map**
- **IPaC Trust Resources Report**









# Appendix F

## Proposed Alternatives Exhibits



**Legend**

-  Crosswalk
-  Sidewalk
-  Off-Road Shared Use Path
-  Paved Bike Lane
-  Right of Way

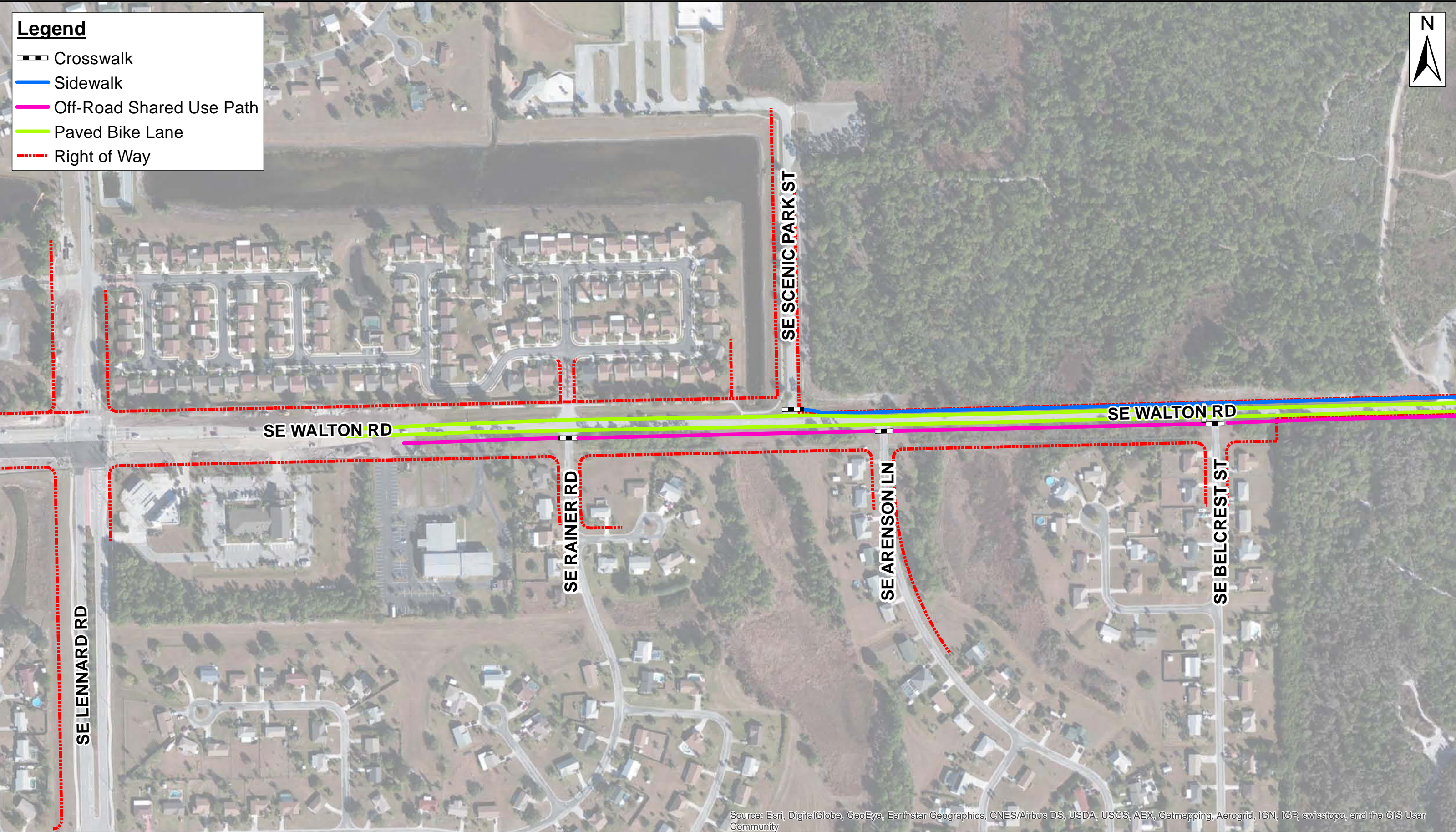

Source: Esri, DigitalGlobe, GeoEye, Earthstar Geographics, CNES/Airbus DS, USDA, USGS, AEX, Getmapping, Aerogrid, IGN, IGP, swisstopo, and the GIS User Community



# Recommended Multimodal Improvements





Walton Road  
Multimodal Improvements Feasibility Study  
Port St. Lucie, FL



May 2016



**Legend**

-  Crosswalk
-  Sidewalk
-  Off-Road Shared Use Path
-  Paved Bike Lane
-  Right of Way

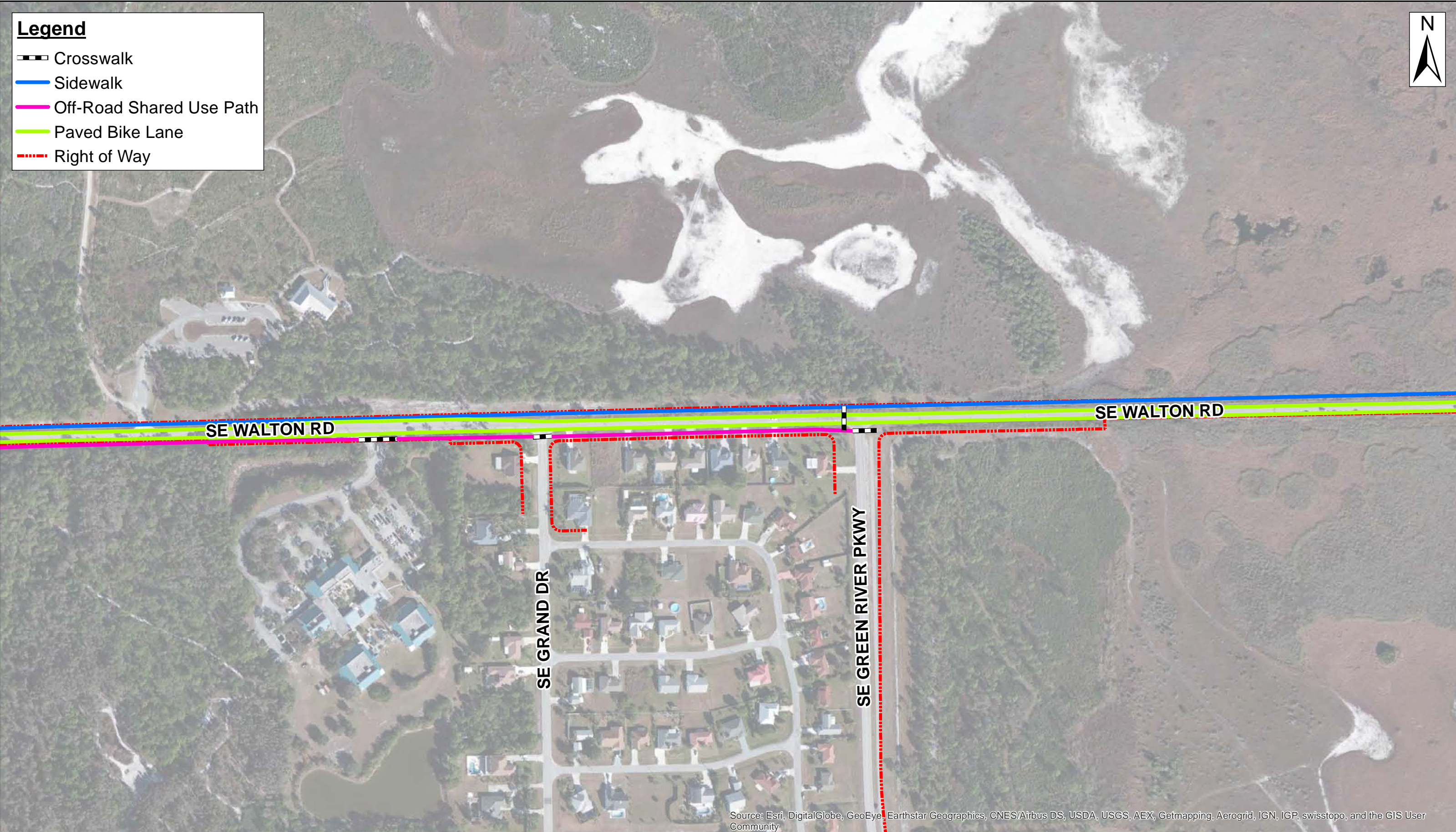

Source: Esri, DigitalGlobe, GeoEye, Earthstar Geographics, CNES/Airbus DS, USDA, USGS, AEX, Getmapping, Aerogrid, IGN, IGP, swisstopo, and the GIS User Community



# Recommended Multimodal Improvements



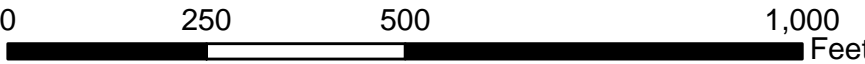

Walton Road  
Multimodal Improvements Feasibility Study  
Port St. Lucie, FL



May 2016



**Legend**

-  Crosswalk
-  Sidewalk
-  Off-Road Shared Use Path
-  Paved Bike Lane
-  Right of Way

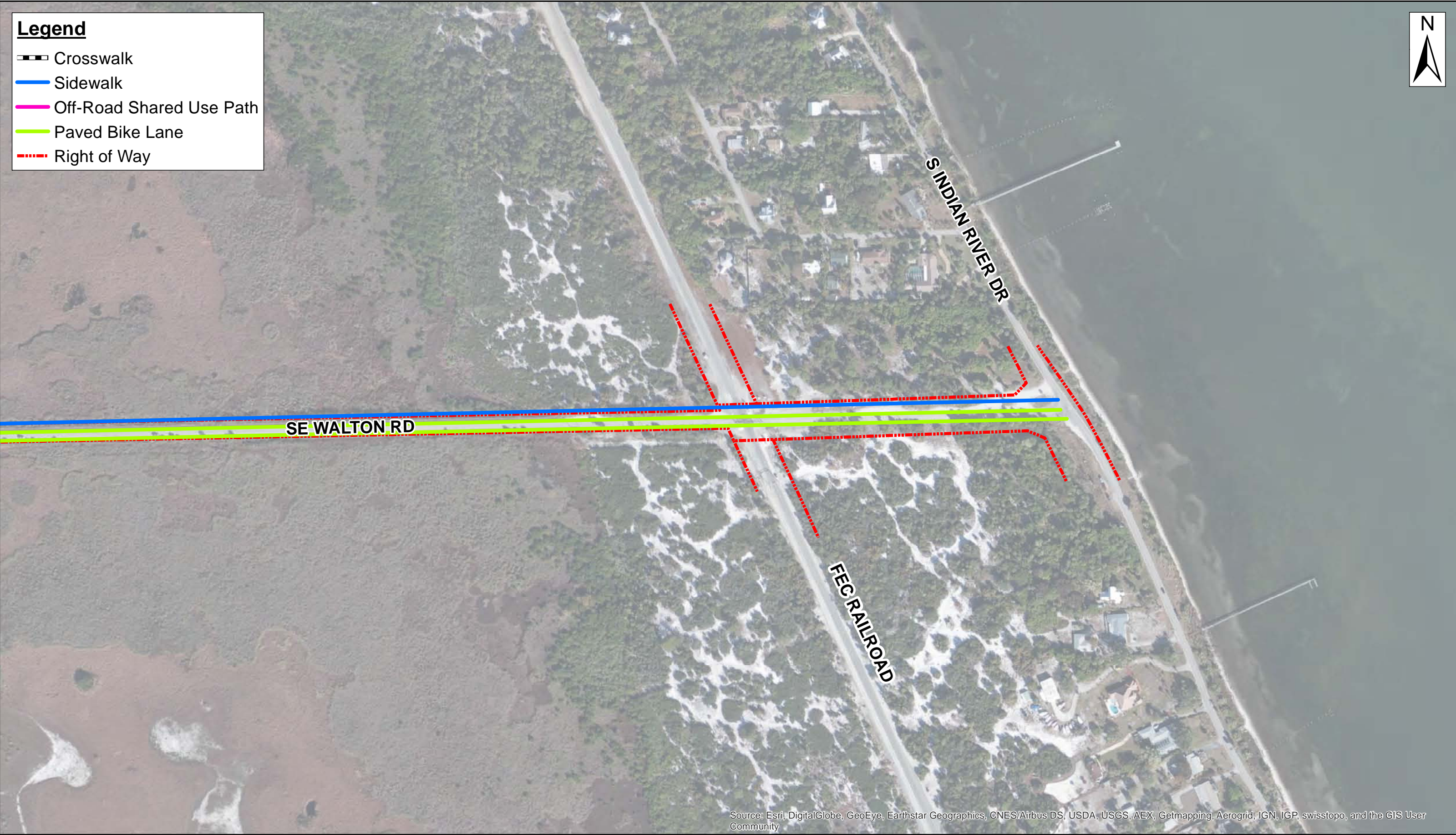

Source: Esri, DigitalGlobe, GeoEye, Earthstar Geographics, CNES/Airbus DS, USDA, USGS, AEX, Getmapping, Aerogrid, IGN, IGP, swisstopo, and the GIS User Community



# Recommended Multimodal Improvements

Walton Road  
 Multimodal Improvements Feasibility Study  
 Port St. Lucie, FL

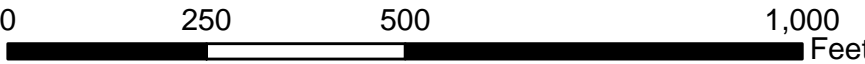

May 2016



# Cost Estimation for Alternatives

## Segment B

Improvement Description	Unit	Price	Total Cost
Roadway with paved shoulders (mile)	0.92	\$ 426,052.54	\$ 391,968.34
Sidewalk (mile)	0.72	\$ 110,391.99	\$ 79,482.23
Multiuse path (mile)	0.92	\$ 231,278.63	\$ 212,776.34
Wooden Boardwalk With Railing, 42" (ft)	800	\$300.00	\$ 240,000.00
Total Cost			\$ 924,226.91

## Segment C

Improvement Description	Unit	Price	Total Cost
Roadway with paved shoulders (mile)	0.8	\$ 426,052.54	\$ 340,842.03
Sidewalk (mile)	0.8	\$ 110,391.99	\$ 88,313.59
Pedestrian railing (LF)	2500	\$ 73.00	\$ 182,500.00
Guardrail (both sides) (LF)	5000	\$ 17.40	\$ 87,000.00
Misc. Pavement (tonnage)	187	\$ 100.00	\$ 18,700.00
Gravity Wall (CY)	500	\$ 600.00	\$ 300,000.00
Total Cost			\$ 1,017,355.62

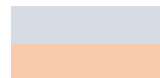
 cost per mile  
 estimated current market price



## Water Crossing Under Walton Road

Item Description	Units	Price	Total Price
Arch Culvert	1	\$ 100,000.00	\$ 100,000.00
Embankment Fill (cy)	8,000	\$ 20.85	\$ 166,800.00
MSE wall (SF)	1800	\$ 69.92	\$ 125,856.00
Bridge Concrete Barrier Wall (SF)	2000	\$ 225.00	\$ 405,000.00
<b>10 % contingency</b>			\$ 79,765.60
Total Alternative Cost			\$ 877,421.60

\*Assume roadway profile raised 8 feet with a 3% grade

## Water Crossing Over Walton Road

Item Description	Units	Price	Total Price
Watercraft Dock/Launch (construction and engineering)	2	\$7,500.00	\$15,000.00
Midblock Pedestrian Signal	1	\$99,148.12	\$99,148.12
Total Alternative Cost			\$114,148.12

cost per mile  
 estimated current market price



1641 Worthington Road, Suite 400, West Palm Beach, FL 33409 \* (561)689-7444 Phone (561)689-3003 Fax



## AGENDA ITEM SUMMARY

<b>Board/Committee:</b>	Bicycle-Pedestrian Advisory Committee (BPAC)
<b>Meeting Date:</b>	May 19, 2016
<b>Item Number:</b>	7a
<b>Item Title:</b>	Strategic Intermodal System (SIS) Multimodal Needs Plan Update
<b>Item Origination:</b>	Florida Department of Transportation District 4 (FDOT)
<b>UPWP Reference:</b>	Task 3.1: Long Range Transportation Planning and MAP-21 Implementation
<b>Requested Action:</b>	Discuss and provide comments to FDOT
<b>Staff Recommendation:</b>	As the update to the SIS Multimodal Needs Plan is underway, it is recommended that local projects potentially eligible for SIS funding be identified to FDOT for inclusion in the SIS Multimodal Needs Plan.

### Attachments

- Staff Report
- SIS Information and Atlas
- SIS Criteria Summary

## **MEMORANDUM**

**TO:** Bicycle-Pedestrian Advisory Committee (BPAC)

**FROM:** Peter Buchwald  
Executive Director

**DATE:** May 4, 2016

**SUBJECT: Strategic Intermodal System (SIS) Multimodal Needs Plan Update**

---

### **BACKGROUND**

The SIS is Florida's statewide network of high priority transportation facilities which include airports, highways, railroads, seaports, spaceports, and transit facilities. Additional information regarding the SIS and a map of SIS facilities are attached.

The SIS Multimodal Needs Plan identifies capacity projects needed for the SIS to meet Florida Transportation Plan Goals and SIS Policy Plan Objectives. The Florida Department of Transportation (FDOT) District 4 will provide a presentation on the process and schedule for updating the SIS Multimodal Needs Plan.

### **ANALYSIS**

FDOT has initiated a process to update the SIS Multimodal Needs Plan from the current horizon year of 2040 to the year 2045. The process began in January 2016 and is scheduled to conclude in March 2017. Coordination with the St. Lucie TPO and other partners is a key component in the process.

Projects associated with SIS facilities are eligible for State funding which is dedicated to the SIS. To become part of the SIS, a facility must meet the criteria and thresholds identified in the attached Summary of Adopted SIS Facility Types, Criteria, and Thresholds.

To receive SIS funding, the project must first be identified as a need in the SIS Multimodal Needs Plan. The SIS Multimodal Needs Plan is the source for projects to receive SIS funding in the SIS Cost Feasible Plan, the 2nd Five-Year SIS Plan, and the 1st Five-Year SIS Plan which is incorporated into the FDOT Work Program for production.

### **RECOMMENDATION**

As the update to the SIS Multimodal Needs Plan is underway, it is recommended that local projects potentially eligible for SIS funding be identified to FDOT for inclusion in the SIS Multimodal Needs Plan.





October 2015

DESIGNATED SIS AND EMERGING SIS FACILITIES					
Facility Type	Active and Planned Drop Facilities			Planned Add Facilities	State Funding Match: State share shown, remaining funds to be obtained from non-State sources
	Corridor   Hub		Connector		
	SIS	Emerging SIS			
Commercial Service Airports	7	10			Up to 50% on hub
General Aviation Relievers	2				Up to 50% on hub
Spaceports	1			1	Up to 50% on hub
Seaports	7	4		1	Up to 50% on hub Up to 75% on water connectors
Freight Terminals	5	2			Up to 50% on hub
Passenger Terminals	22	9		3	Up to 50% on hub
Rail (Miles)	1,704	357	236	22	Up to 100% on mainline Up to 75% on connector
Highway (Centerline Miles)	3,535	760	254	100	100%
Highway (Lane Miles)	16,453	2,224	941	115	100%
Waterway (Miles)	1,950	312			100%

**Upcoming 2015 SIS Policy Plan Update**

Florida’s SIS Policy Plan is developed with extensive partner and public involvement every five years. Work is now underway to update the plan with completion expected in January 2016. Information is being posted on the FTP/SIS website during this update process and we invite you to participate and be involved as we evaluate the existing plan and develop a policy framework for Florida’s most strategic transportation facilities. To sign up for email subscriptions or for the latest documents and information please visit the website at:

<http://www.floridatransportationplan.com/>.

**For more information, please contact**

Brian Watts, SIS Policy Manager (850) 414-4818 Email: <a href="mailto:brian.watts@dot.state.fl.us">brian.watts@dot.state.fl.us</a>	Chris Edmonston, SIS Implementation Manager (850) 414-4813 Email: <a href="mailto:chris.edmonston@dot.state.fl.us">chris.edmonston@dot.state.fl.us</a>
Sarah Catala, District 1 SIS Coordinator (Southwest Florida) (239) 225-1981 Email: <a href="mailto:sarah.catala@dot.state.fl.us">sarah.catala@dot.state.fl.us</a>	Barney Bennette, District 2 SIS Coordinator (Northeast Florida) (386) 961-7878 Email: <a href="mailto:barney.bennette@dot.state.fl.us">barney.bennette@dot.state.fl.us</a>
Ray Kirkland, District 3 SIS Coordinator (Northwest Florida) (850) 415-9590 Email: <a href="mailto:ray.kirkland@dot.state.fl.us">ray.kirkland@dot.state.fl.us</a>	Lisa Dykstra, District 4 SIS Coordinator (Southeast Florida) (954) 777-4360 Email: <a href="mailto:lisa.dykstra@dot.state.fl.us">lisa.dykstra@dot.state.fl.us</a>
John Zielinski, District 5 SIS Coordinator (East Central Florida) (407) 482-7868 Email: <a href="mailto:john.zielinski@dot.state.fl.us">john.zielinski@dot.state.fl.us</a>	Ken Jeffries, District 6 SIS Coordinator (Miami-Dade, Monroe County) (305) 470-5445 Email: <a href="mailto:ken.jeffries@dot.state.fl.us">ken.jeffries@dot.state.fl.us</a>
Lori Marable, District 7 SIS Coordinator (Tampa Bay Area) (813) 975-6450 Email: <a href="mailto:lori.marable@dot.state.fl.us">lori.marable@dot.state.fl.us</a>	Shannon Estep, Turnpike Enterprise SIS Coordinator (407) 532-3999 Email: <a href="mailto:shannon.estep@dot.state.fl.us">shannon.estep@dot.state.fl.us</a>

Florida’s Strategic Intermodal System (SIS) comprises Florida’s statewide network of high priority transportation facilities, including the state’s largest and most significant airports, spaceports, deepwater seaports, freight rail terminals, interregional rail and bus terminals, rail corridors, urban fixed guideway transit corridors, waterways, and highways. SIS facilities are the primary means for moving people and freight between Florida’s diverse regions, as well as between Florida and other states and nations. The SIS is Florida’s highest statewide priority for transportation capacity improvements.

There are three types of designated facilities:

- Transportation **hubs** (ports and terminals) moving people or goods;
- Interregional **corridors** (highways, rail lines, waterways and urban fixed guideway transit facilities) connecting major origin/destination markets; and
- Intermodal **connectors** (highways, rail lines, or waterways and other exclusive use facilities) linking hub-to-corridor; hub-to-hub; or strategic military installation-to-corridor.

Two system components are collectively known as “The SIS”:

- **SIS** facilities meeting high levels of people and goods movement, generally supporting major flows of interregional, interstate, and international trips; and
- **Emerging SIS** facilities meeting lower levels of people and goods movement, generally serving fast growing economic regions and Rural Areas of Opportunity.

The SIS Strategic Plan in 2005 heralded a shift in the way FDOT and partners plan Florida’s transportation future. The current 2010 SIS Strategic Plan further defines the state’s primary role in transportation focusing on international, interstate, and interregional travel and transport of people and goods, with emphasis on the SIS. At the same time, stronger regional partnerships are encouraged to identify and invest in regionally significant transportation facilities, while local governments lead in addressing local movements of people and goods.

The 2010 SIS Strategic Plan and accompanying documents, maps and resources are available on the SIS website at [www.dot.state.fl.us/planning/sis](http://www.dot.state.fl.us/planning/sis).





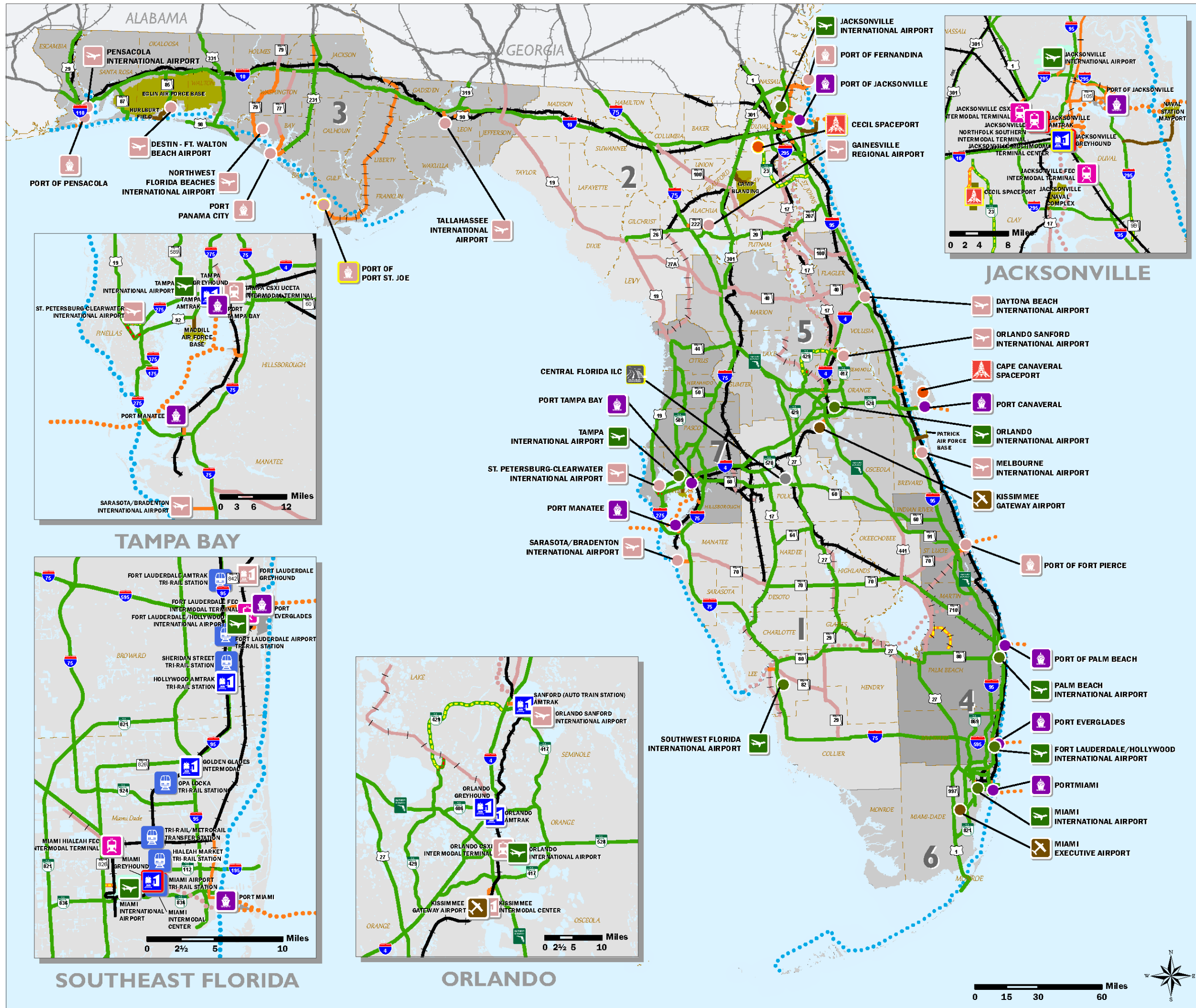

# SIS atlas

**Airports & Spaceports**

- SIS Commercial Service Airport
- Emerging Commercial Service SIS Airport
- SIS General Aviation Reliever Airport
- SIS Spaceport

**Seaports**

- SIS Seaport
- Emerging SIS Seaport

**Freight Rail Terminals**

- SIS Freight Rail Terminal
- Emerging SIS Freight Rail Terminal

**Intermodal Logistic Center**

- SIS Intermodal Logistic Center

**Passenger Terminals**

- SIS Passenger Terminal
- Emerging SIS Passenger Terminal

**Urban Fixed Guideway Transit**

- SIS Urban Fixed Guideway Station

**Highway**

- SIS Highway Corridor
- Emerging SIS Highway Corridor
- SIS Highway Connector
- Military Access Facility

**Rail**

- SIS Railway Corridor
- Emerging SIS Railway Corridor
- SIS Railway Connector

**Waterways**

- SIS Waterway
- Emerging SIS Waterway
- SIS Waterway Connector

**Facilities: Planned Add & Drop**

- Planned Add
- Planned Drop

# Summary of Adopted SIS Facility Types, Criteria, and Thresholds<sup>1</sup>

Facility Type	Eligible Facilities	SIS Component	Emerging SIS Component
<b>Commercial Service Airports</b>	Airports with scheduled commercial and/or cargo services	0.25% of U.S. total passenger or freight activity	<i>Located at least 50 miles from a SIS commercial service airport<sup>2</sup> and</i>  0.05% of U.S. total passenger or freight activity or 0.01% of U.S. total passenger or freight activity <b>and</b> 0.05% of employment of industries dependent on aviation transportation <sup>3</sup>
<b>General Aviation Reliever Airports</b>	General aviation airports functioning as relievers to commercial service airports	Identified as a reliever facility to an existing SIS commercial service airport <i>AND</i> Handles at least 75,000 itinerant (nonlocal) flight operations per year <i>AND</i> Has a runway with length exceeding 5,500 linear feet <i>AND</i> Has runway capable of handling 60,000 pound dual wheel aircraft and serviced by precision instrument approach <i>AND</i> 0.05% of employment of industries dependent on air transportation located within a 50 mile radius <sup>3</sup>	Identified as a reliever facility to an existing Emerging SIS commercial service airport <i>AND</i> Handles at least 75,000 itinerant (nonlocal) flight operations per year <i>AND</i> Has a runway with length exceeding 5,500 linear feet <i>AND</i> Has runway capable of handling 60,000 pound dual wheel aircraft and serviced by precision instrument approach <i>AND</i> 0.05% of employment of industries dependent on air transportation located within a 50 mile radius <sup>3</sup>
<b>Spaceports</b>	Spaceport territory as defined in s. 331.304, Florida Statutes or by Space Florida	Regularly scheduled civil, commercial or military launches resulting in suborbital or orbital flights	Not Applicable
<b>Seaports</b>	Deepwater ports as defined in s.311.09, Florida Statutes	500,000 home-port passengers or 0.25% of U.S. total freight activity	<i>Located at least 50 miles from a SIS seaport<sup>2</sup> and</i>  250,000 home-port passengers or 0.05% of U.S. total freight activity or 50,000 home-port passengers and 0.01% of U.S. total freight activity and <ul style="list-style-type: none"> <li>• 0.05% of employment of industries dependent on waterborne transportation<sup>3</sup></li> </ul>
<b>Interregional Passenger Terminals</b>	Rail, bus, or multimodal terminals serving interregional or interstate passengers and providing on-site ticketing and support services	0.25% of U.S. total bus and/or rail interregional passengers per year (100,000 per year floor)	<i>Located at least 50 miles from a SIS passenger terminal<sup>2</sup> and</i>  0.125% of U.S. total bus and/or rail interregional passengers (50,000 per year floor) or 0.063% of U.S. total bus and/or rail interregional bus passengers <b>and</b> 0.05% employment in industries dependent on interregional passenger transportation located within a 50 mile radius <sup>3</sup>
<b>Freight Rail Terminals</b>	Carload and intermodal terminals	0.25% of U.S. total annual rail freight activity	<i>Located at least 50 miles from a SIS freight rail terminal<sup>2</sup> and</i>  0.05% of U.S. total rail freight activity or 0.01% of U.S. total rail freight activity <b>and</b> <ul style="list-style-type: none"> <li>• 0.05% employment of industries dependent on freight rail transportation<sup>3</sup></li> </ul>

<sup>1</sup>See master list of adopted SIS Designation Criteria, Thresholds and Implementation Guidance for the full listing of official criteria and data details. For all types of facilities, community and environment screening criteria are applied prior to a final designation decision.

<sup>2</sup>Exceptions to the 50 mile minimum distance can be made for hubs serving a significantly different market segment from the nearest SIS hub.

<sup>3</sup>Minimum share of U.S. total employment may be reduced to 0.01% in designated Rural Areas of Critical Economic Concern.

<sup>4</sup>Rail corridors designated prior to adoption of new criteria in 2010 remain designated; additional rail owners must apply and demonstrate they meet these criteria.



# Summary of Adopted SIS Facility Types, Criteria, and Thresholds<sup>1</sup>

Facility Type	Eligible Facilities	SIS Component	Emerging SIS Component
<b>Intermodal Logistics Centers</b>	Intermodal Logistics Center as defined by s. 311.101 and s. 339.63, Florida Statutes	Supports trade moving to or from a SIS seaport or airport <b>and</b> identified in a local government comprehensive plan or development order  <i>AND</i> Meets minimum size thresholds consistent with other SIS hub criteria for the type of intermodal movement primarily handled by the ILC	Supports trade moving to or from a SIS seaport or airport and identified in a local government comprehensive plan or development order  <i>AND</i> Meets minimum size thresholds consistent with other SIS hub criteria for the type of intermodal movement primarily handled by the ILC <b>or</b> meets economic connectivity thresholds consistent with other Emerging SIS hub criteria
<b>Passenger Rail Corridors</b>	Rail corridors <sup>4</sup>	Provides scheduled interregional or interstate passenger service	Not Applicable
<b>Freight Rail Corridors</b>	Rail corridors <sup>4</sup>	At least 10 million gross ton miles of freight per mile	At least 5 million gross ton-miles of freight per mile <i>OR</i> 2.5 million gross ton miles of freight per mile <b>and</b> provides service to a county with 0.05% of U.S. total employment of industries dependent on freight rail transportation <sup>3</sup>
<b>Waterways</b>	Navigable waterways	Intracoastal waterways and coastal shipping lanes <i>OR</i> Inland deep draft waterways with 0.25% of total U.S. annual waterway freight tonnage <i>OR</i> Inland shallow draft waterways with 0.25% of total U.S. domestic waterway freight tonnage	Interregional deep draft waterways with 0.05% of total U.S. waterway freight tonnage <i>OR</i> Inland shallow draft waterways with 0.05% of total U.S. annual domestic waterway freight tonnage <i>OR</i> 0.05% of U.S. total employment of industries dependent on waterborne transportation
<b>Highways</b>	State Highways	Designated Interstate facility <i>OR</i> Designated National Highway System facility providing connections to major markets in Alabama or Georgia <i>OR</i> Designated State Highway System limited access facility connecting two or more economic regions with each end at a SIS facility	Designated State Highway System facility connecting two or more economic regions with each end at a SIS facility <i>OR</i> Designated State Highway System facility serving a Rural Areas of Critical Economic Concern with each end at a SIS facility and meeting vehicle or truck volume criteria
<b>Urban Fixed Guideway Transit Corridors</b>	Urban fixed guideway transit corridors	Connects multiple urbanized area counties and serves as a regionally significant facility within single economic region (Note: criteria applied to individual corridors rather than the entire regional transit system)	Not Applicable
<b>Urban Fixed Guideway Transit Hubs</b>	Urban fixed guideway transit stations (Note: All qualifying stations are designated as part of the corridor)	Located at or near the termini of the urban fixed guideway corridor <i>OR</i> Serves a SIS airport, seaport, or spaceport; <i>OR</i> Are integrated with other passenger rail or bus systems providing connections to other regions or states	Not Applicable
<b>Intermodal Connectors</b>	State or local roads, rail lines, fixed guideway transit lines, and waterways	Three types of connectors can be designated: <ul style="list-style-type: none"> <li>• Hub-to-corridor (connecting a hub to the nearest, most appropriate corridor)</li> <li>• Hub-to-hub (connecting a hub to another hub for freight or passenger movement)</li> <li>• Military access facility (connecting a strategic military installation to the nearest, most appropriate SIS corridor)</li> </ul>	Not Applicable

<sup>1</sup>See master list of adopted SIS Designation Criteria, Thresholds and Implementation Guidance for the full listing of official criteria and data details. For all types of facilities, community and environment screening criteria are applied prior to a final designation decision.

<sup>2</sup>Exceptions to the 50 mile minimum distance can be made for hubs serving a significantly different market segment from the nearest SIS hub.

<sup>3</sup>Minimum share of U.S. total employment may be reduced to 0.01% in designated Rural Areas of Critical Economic Concern.

<sup>4</sup>Rail corridors designated prior to adoption of new criteria in 2010 remain designated; additional rail owners must apply and demonstrate they meet these criteria.

For more information please contact:  
 Brian Watts, FDOT, Office of Policy Planning  
 Email: [brian.watts@dot.state.fl.us](mailto:brian.watts@dot.state.fl.us)  
 (850) 414-4818



Effective January 2014



## AGENDA ITEM SUMMARY

<b>Board/Committee:</b>	Bicycle-Pedestrian Advisory Committee (BPAC)
<b>Meeting Date:</b>	May 19, 2016
<b>Item Number:</b>	7b
<b>Item Title:</b>	Crossroads Mountain Biking Trail Update
<b>Item Origination:</b>	BPAC
<b>UPWP Reference:</b>	Task 3.5: Bicycle/Pedestrian/Greenway Planning Task 5.2: Intergovernmental Planning and Coordination
<b>Requested Action:</b>	Discuss and identify next steps
<b>Staff Recommendation:</b>	It is recommended that an update be provided by BPAC members on the status of the Crossroads Mountain Biking Trail located in Fort Pierce that was discussed during the "Comments from the Public" agenda item at the March 10th BPAC meeting and that the next steps be identified.

### **Attachments**

- None